

# General Engineering Catalog

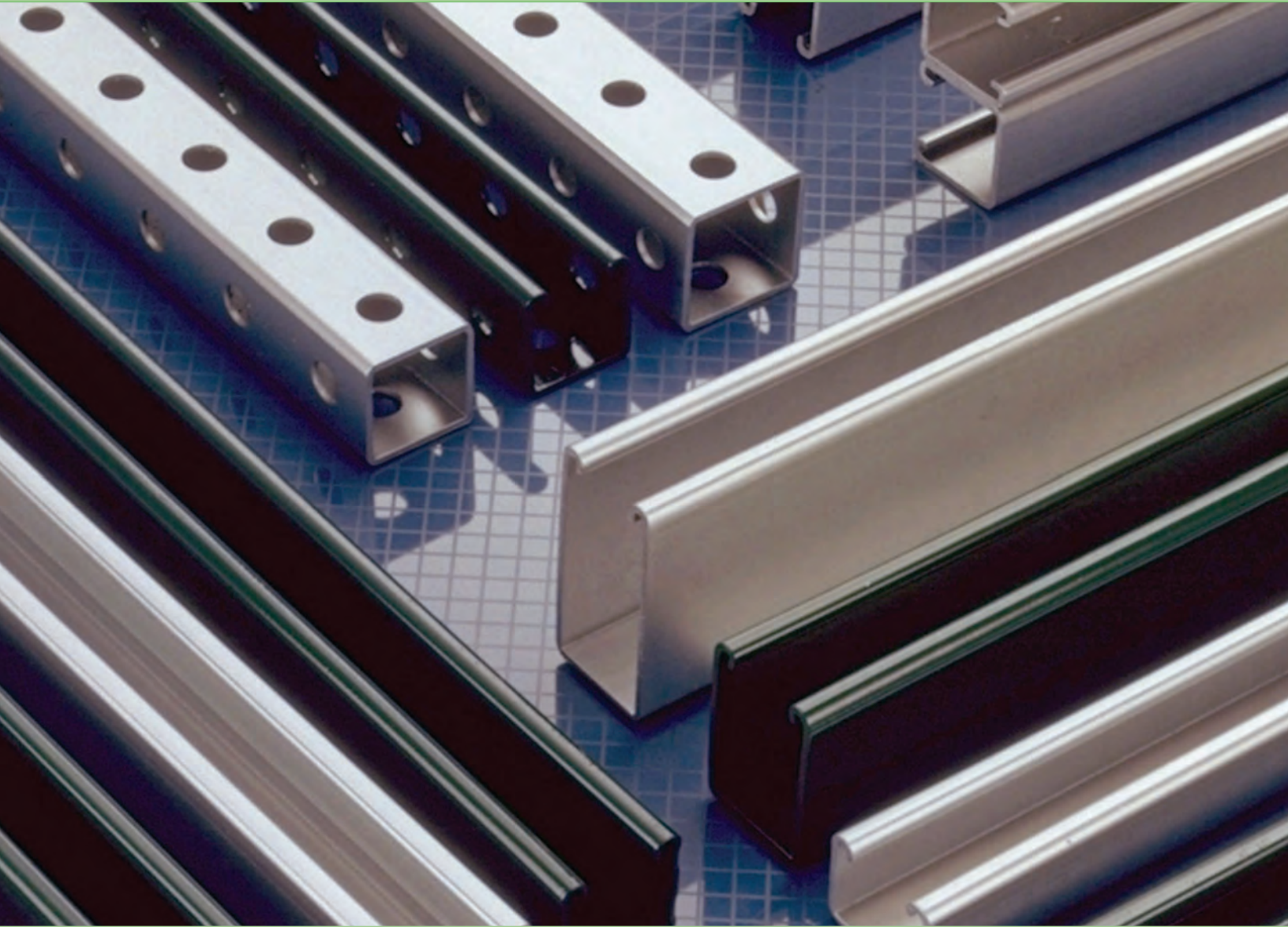

**Atkore**<sup>™</sup>  
Power-Strut

<p><b>General Information</b></p> <p>Product Overview . . . . . 4-5</p> <p>Example Applications . . . . . 6-7</p> <p>Finishes . . . . . 8-9</p> <p>Material Specifications . . . . . 10</p> <p>Pictorial Table of Contents . . . . . 11-18</p>	<p><b>Electrical</b></p> <p>Overview . . . . . 79</p> <p>Channel Raceway . . . . . 80</p> <p>Example Applications . . . . . 81-83</p> <p>Electrical Fittings, Boxes, &amp; Accessories . . . . . 84-90</p>	<p><b>Fiberglass Channel &amp; Accessories</b></p> <p>Overview . . . . . 127</p> <p>Aickinstrut Specifications . . . . . 128-129</p> <p>Chemical Compatibility Table . . . 130-131</p> <p>General Information . . . . . 132</p> <p>Channel Profiles &amp; Loading . . . 133-135</p> <p>Fittings . . . . . 136-138</p> <p>Pipe Clamps &amp; Capping . . . . . 139-142</p> <p>Fasteners / U-Bolts . . . . . 142-144</p> <p>Pipe Hangers, Accessories, &amp; Supports . . . . . 145-147</p> <p>Post Bases . . . . . 148</p>
<p><b>Power-Strut Metal Channel</b></p> <p>Overview . . . . . 19</p> <p>Pull-Out &amp; Slip Loads . . . . . 20</p> <p>Product Profiles . . . . . 20-21</p> <p>PS 100 Channel . . . . . 22-23</p> <p>PS 150 Channel . . . . . 24-25</p> <p>PS 200 Channel . . . . . 26-29</p> <p>PS 210 Channel . . . . . 30-31</p> <p>PS 300 Channel . . . . . 32-33</p> <p>PS 400 Channel . . . . . 34-35</p> <p>PS 500 Channel . . . . . 36-37</p> <p>PS 520 Channel . . . . . 38-39</p> <p>PS 560 Channel . . . . . 40-41</p> <p>Accessories . . . . . 42</p> <p>Lateral Bracing . . . . . 42</p>	<p><b>Concrete Inserts</b></p> <p>Overview . . . . . 91</p> <p>Products . . . . . 92-94</p>	<p><b>Technical Data</b></p> <p>Overview . . . . . 149</p> <p>Formulas . . . . . 150-151</p> <p>Beam Loads . . . . . 152</p> <p>Fitting Loads . . . . . 153</p> <p>Pipe Spacing . . . . . 154-155</p> <p>Channel &amp; Trap Members . . . . . 156</p> <p>Tubing, Conduit, &amp; Pipe Data . . . 157-162</p> <p>Flanges, Channels &amp; I Beams . . . 163-164</p> <p>Conversion Table . . . . . 165</p> <p>Part Number Index . . . . . 166-174</p>
<p><b>Fasteners</b></p> <p>Overview &amp; Product Usage Chart . . 43-44</p> <p>Fasteners . . . . . 45-48</p>	<p><b>Solar Components</b></p> <p>Overview . . . . . 95</p> <p>Components . . . . . 96-98</p>	
<p><b>Fittings</b></p> <p>Overview . . . . . 49</p> <p>General Fittings . . . . . 50-59</p> <p>Wing Connectors . . . . . 59-61</p> <p>Post Bases . . . . . 61-62</p> <p>Trolleys . . . . . 62</p> <p>Brackets &amp; Supports . . . . . 62-65</p> <p>Beam &amp; "C" Clamps . . . . . 65-68</p>	<p><b>Unipier®</b></p> <p>Overview . . . . . 99</p> <p>Sleeper Support . . . . . 100-101</p> <p>Strut Support . . . . . 102-104</p> <p>Gas and Mechanical Support . . . 105-107</p> <p>Pipe Hanger Bases . . . . . 108-109</p> <p>Fabricated Supports . . . . . 110-112</p> <p>Installation . . . . . 113</p> <p>Pipe Diameters and Loading . . . . . 114</p> <p>Technical Data . . . . . 115-116</p>	
<p><b>Pipe &amp; Conduit Clamps</b></p> <p>Overview . . . . . 69</p> <p>Clamps . . . . . 70-76</p> <p>Pipe Rollers . . . . . 77-78</p>	<p><b>Junior Channel</b></p> <p>Overview . . . . . 117</p> <p>PS 600J Channel . . . . . 118</p> <p>PS 700J Channel . . . . . 119</p> <p>Accessories . . . . . 118 - 120</p>	
	<p><b>Power-Angle</b></p> <p>Overview . . . . . 121</p> <p>Products . . . . . 122</p> <p>Loads &amp; Configurations . . . . . 123-126</p>	

**WARNING:** Power-Strut products are carefully designed and manufactured to the listed standards, as applicable. However, Power-Strut reserves the right to revise product design without notification. Power-Strut products included in this catalog are intended for installation and service only as described or specified herein. Care should be exercised by installers and end-users to install, use and maintain these products properly to avoid any possible on-the-job accidents.

## *A Broad and Versatile Metal Framing Line Backed*



### More Than 8,000 Quality Products

The Power-Strut metal framing system can be regarded as a basic building material. Our metal framing system is an erector set concept, using channel and fittings to solve many applications. You can conceal metal framing in the basic structure of a building or run it along the surface of walls, ceilings and floors. An endless array of fittings provide freedom to work at virtually any angle along any surface to shape a support system that fits your exact needs.

Available finishes include hot-dipped galvanized, pregalvanized, electro-galvanized and painted, along with material choices of steel, stainless steel and aluminum.

Beyond its versatility as a basic building material, metal framing is popular for more exotic applications such as clean rooms, satellite dish supports, x-ray supports, storage racks, theater screens, tunnel stanchions and offshore platform catwalks. While the uses of metal framing are truly unlimited, they fall in to three major categories.

### Electrical Systems



Versatile metal framing is widely used by electrical contractors to support conduit, panel boxes, raceway systems and other electrical components. In addition, Power-Strut channel can be used as a wiring raceway. Products marked with the UL symbol in this catalog are listed by Underwriter's Laboratories for use in raceway applications.

Channel raceways or support systems can be attached to ceilings, wood or steel beams, inside columns or imbedded in concrete. Trapeze systems can support conduit from either the top or bottom.



As a lighting support system, metal framing helps assure proper alignment over long spans. As a raceway system, channel offers an opportunity to reduce construction costs through more efficient use of installation labor. The exceptional versatility of channel gives contractors more flexibility in solving miscellaneous problems which may arise at the job site.

*by a Leading Reputation for Quality and Service.*



### **Mechanical Systems That Reduce Costs**

For mechanical support of HVAC, plumbing and fire protection systems, the versatility of metal framing systems is unmatched. It is by far the most popular framing system with contractors because the wide variety of fittings and support devices available help solve virtually any support problem without expensive welding.

Piping stanchions, ceiling and wall-mounted supports and tunnel supports are common metal framing applications. Concrete insert, shelf bracket, wall and ceiling-mounted systems provide flexible solutions to any piping support applications.

In addition, pipe support products such as Power-Wrap and cushioned clamps provide insulation to prevent potential damage from noise, vibration, temperature variations and metal-to-metal contact.

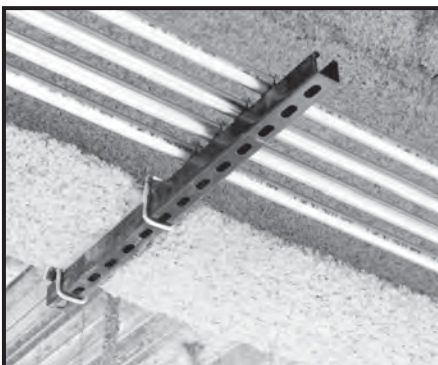

### **OEM Components and Maintenance**

Metal Framing systems provide convenient solutions for maintenance and retrofit requirements in processing and manufacturing facilities. Also, Power-Strut products can be used as cost-effective components in OEM applications. For example, channel can be used as conveyor stands and side rails or provide framing for panel cabinetry products, or for generator, motor and pump supports.

The complete line of products and leading reputation for quality and service make Power-Strut your practical choice for metal framing. Contact your local Power-Strut representative for additional information.



## Overhead Support Vertical to Horizontal

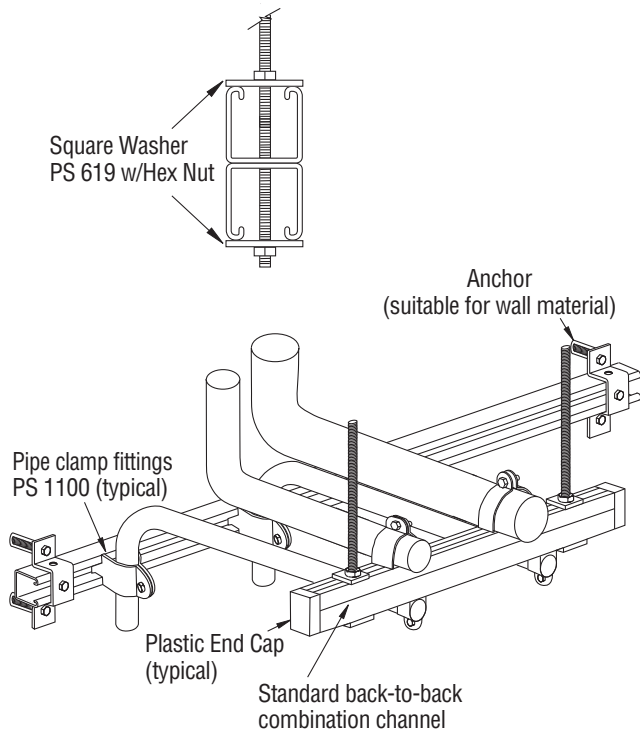

## Wall Mount Organize & Control MultiShelf or Utility Support

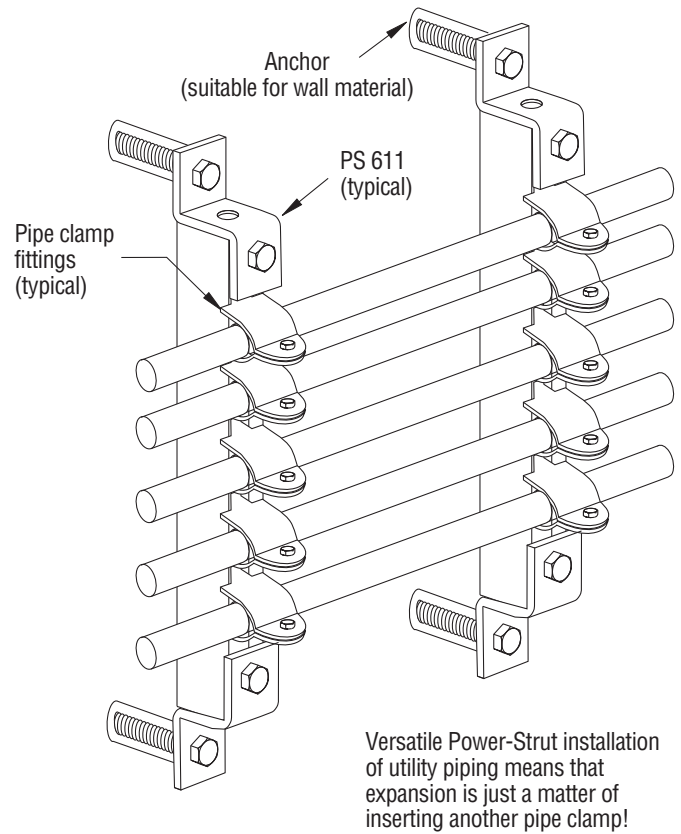

## Overhead Multi-Use Support Systems Using Channel Attached to "I" Beams

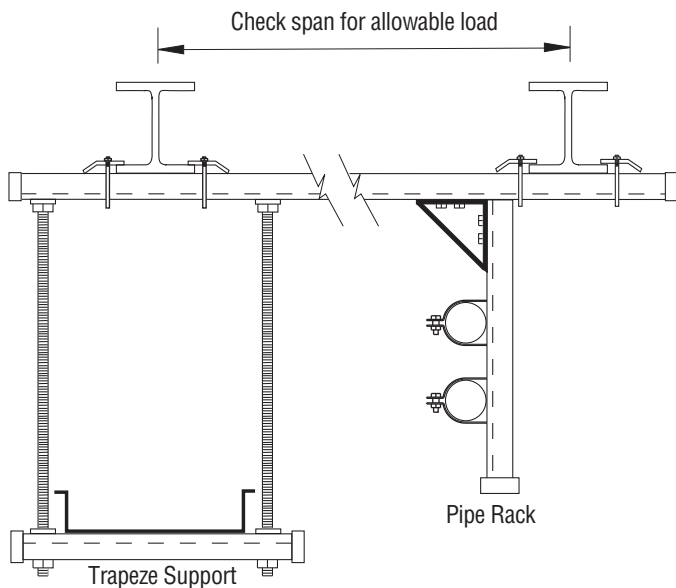

## Wall Mounted Brackets

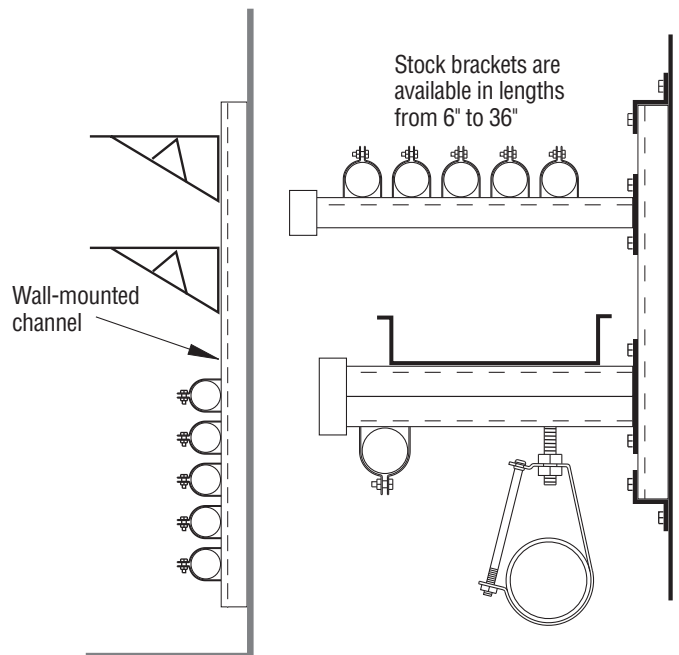

**Standard Channel and Fitting Assembly**

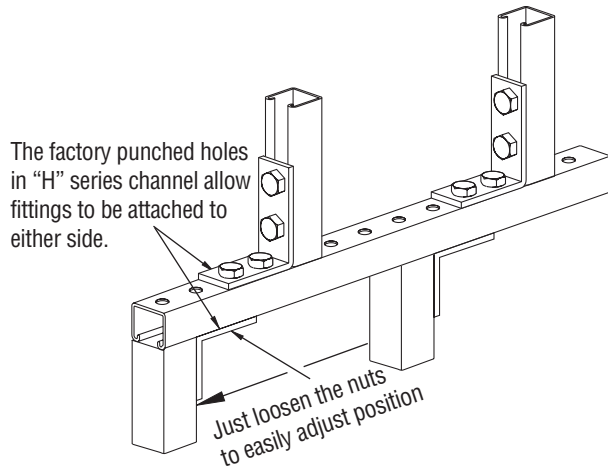

**Supports for Threaded Rod Attachments Between Beams**

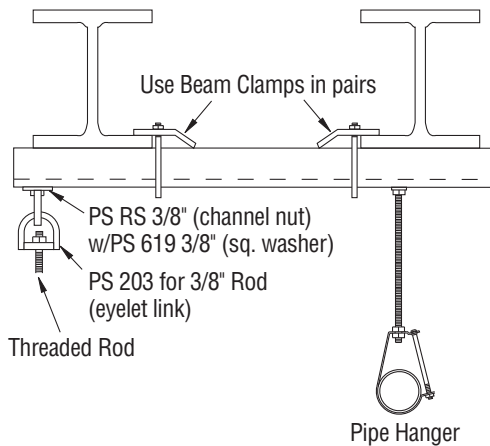

Select channel size based on load requirements

**Supports for Threaded Rod Attachments to Single Beams**

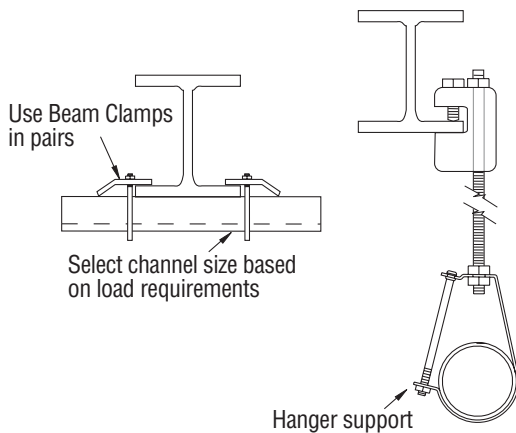

**Trapeze Support System**

Power-Strut metal framing is ideal for electrical and mechanical pipe support applications.

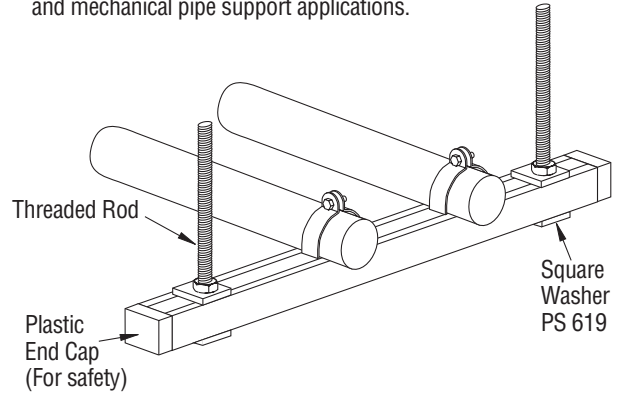

**Acceptable Methods to Hang Channels**

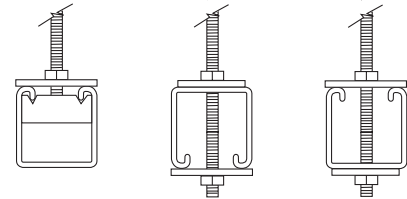

Pre-slotted channel allow through channel connections

**Ganged Pipe Support**

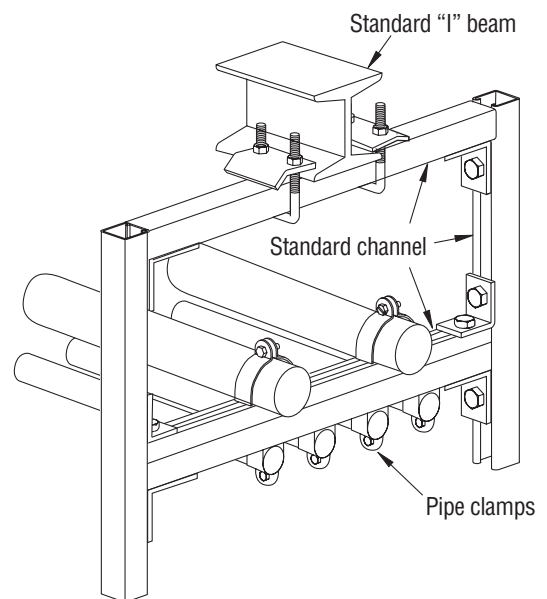

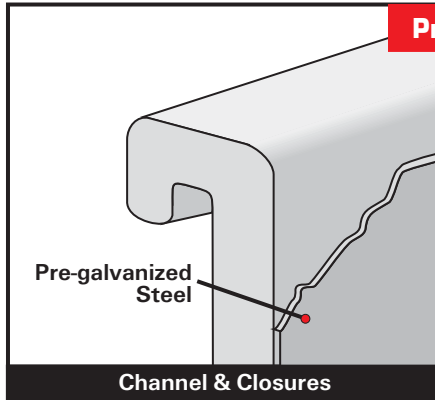

### Pregalvanized (PG)

Material (steel strip) is coated with zinc by hot-dip process prior to roll-forming or press operations.

The zinc coating conforms to ASTM A653, Grade 90 General Requirement for Steel Sheet, Zinc-Coated (Galvanized) by Hot Dip Process.

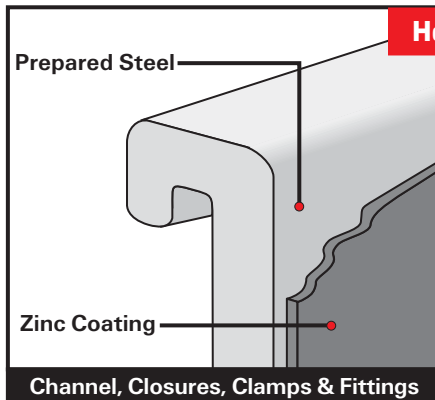

### Hot-Dipped Galvanized (HG)

Material is coated with zinc after being roll-formed or after all manufacturing operations are completed, conforming to ASTM A123 or A153.

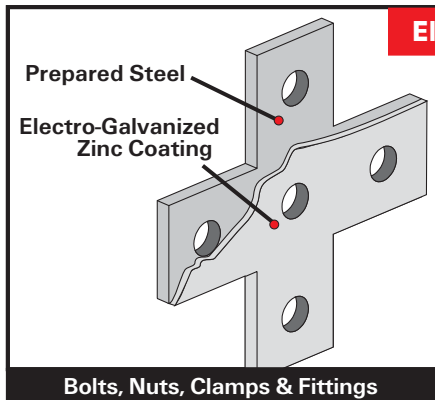

### Electro-Galvanized (EG)

Fittings and hardware are electrolytically coated with zinc to commercial standards (ASTM-B633 Type III C1).

SC1 (mild) has a Zinc coating of 0.2 and is recommended for dry indoor use. SC1 is the standard finish thickness.

SC3 (Severe) has a Zinc coating of 0.5 mill and is the standard finish thickness only on UL Listed raceway products.

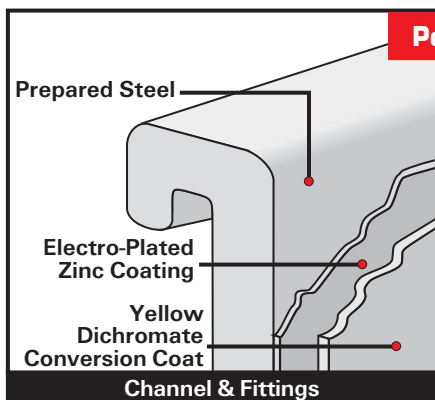

### Power-Gold (ZD)

An Electro-galvanized zinc plate is applied with a cohesive molecular bond to the steel base metal, in compliance with the ASTM B633 standard. Yellow Dichromate is applied over the zinc and results in a gold appearance which acts as a nonporous barrier sealant.

SC1 (mild), recommended for dry indoor use, has a Zinc coating of 0.2 and is the standard finish thickness

SC3 (Severe) has a Zinc coating of 0.5 mill and is the standard finish thickness only on UL Listed raceway products.

## ZINC COATING

Power-Strut products are available in four types of zinc coatings:

- Electroplated (EG)
- Pregalvanized (PG)
- Hot-Dipped Galvanized (HG)
- Yellow Dichromate (ZD)

Zinc coatings offer two types of protection:

- 1. Barrier:** The zinc coating protects the steel substrate from direct contact with the environment.
- 2. Sacrificial:** The zinc coating will protect scratches, cut edges, etc. through an anodic sacrificial process.

The service life of zinc coating is directly related to the zinc coating thickness as shown below.

### COMPARISON OF ZINC GALVANIZED FINISHES

Finish	Zinc Thickness
Hot-Dipped Galvanized	2.6 MIL
Pregalvanized	0.75 MIL
Electro-Galvanized (SC1)	0.2 MIL
Electro-Galvanized (SC3)	0.5 MIL
Power-Gold (SC1)	0.2 MIL
Power-Gold (SC3)	0.5 MIL

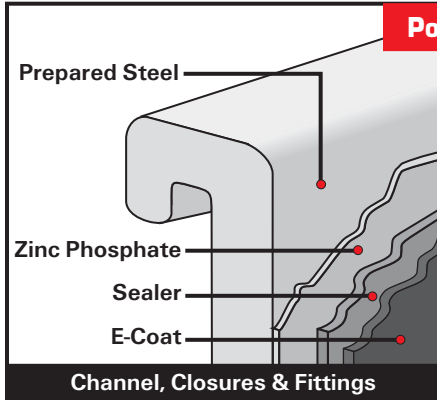

**Power-Green® (GR)**

Channel and parts are cleaned and phosphated. Immediately afterward, a uniform coat of rust-inhibiting thermoset epoxy paint is applied by cathodic electro-deposition and thoroughly baked.

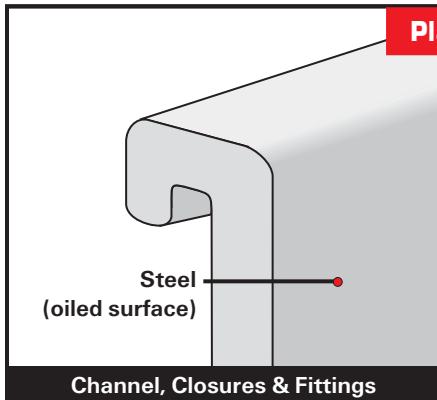

**Plain (PL)**

Plain finish designation means that the channel retains the oiled surface applied to the raw steel during the rolling process. The fittings have the original oiled surface of the bar-stock material.

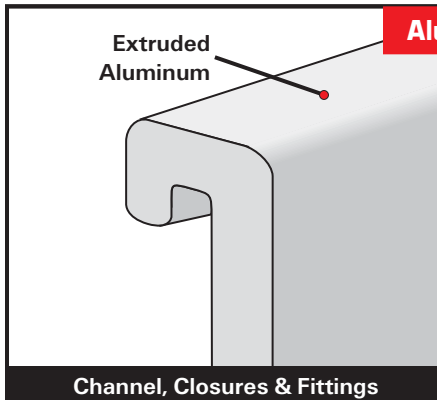

**Aluminum (AL)**

Channel is extruded aluminum in accordance with ASTM B221 Type 6063-T6.

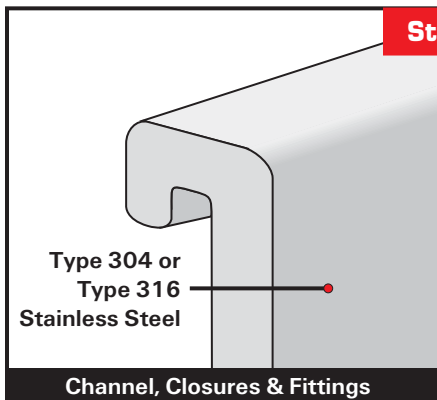

**Stainless Steel (SS)**

Material in accordance with ASTM A240 (Type 304 or type 316).

**POWER-GREEN®  
TECHNICAL DATA**

**STEEL SUBSTRATE PREPARATION**

Eight stage continuous cleaning, rinse, zinc phosphate conversion coating and sealer.

**COATING**

Thermoset epoxy

**Color:** Federal Highway Green  
Color Tolerance Chart  
PR Color No. 4.

**Hardness:** 2H+

**Coating Process:** Cathodic  
Electrodeposition.

**PERFORMANCE**

**Salt Spray:**

**Scribed:** exceeds 400 hrs per  
ASTM B117. (1/8 Creep)

**Unscribed:** exceeds 600 hours per  
ASTM B117. (6% Red Rust)

**ENVIRONMENTAL ISSUES**

Formulated as a "heavy metal"- free coating (trace elements only).

**Outgassing in service:** essentially none at 350°F for 24 hrs.

**Finishes (Ordering):**

When ordering, add the finish to the part number.

- Examples: PS 200-10 PG  
PS 200-10 ZD  
PS 200-10 GR  
PS 200-10 HG



## Materials:

### Channel\* & Closures – Pregalvanized

ASTM A653 Grade 33, Steel Sheet Zinc Coated by Hot Dip Process

### Channel\* – Plain, Painted or Hot Dip Galvanized

ASTM A-1011 Grade 33, Hot Rolled Carbon Steel Sheet and Strip, Structural Quality

### Channel\* – Stainless Steel

ASTM A-240, Type 304, Heat Resisting Chromium and Chromium-Nickel Stainless Steel Plate, Sheet, Strip for Pressure Vessel

### Channel\* – Aluminum

ASTM B-221, Type 6063 T6, Aluminum Alloy Extruded Bar, Rod, Wire, Shape and Tube

### Closures – Plain, Painted or Hot Dip Galvanized

ASTM A1008, Steel, Strip, Carbon, Cold-Rolled

### Fittings\* – Steel

ASTM A575, A576, A635, A1011 SS Grade 33, A1011 HSLAS Grade 45 or A36

### Fittings\* – Aluminum

ASTM B-209

### Accessories – Steel

ASTM A575, A576, A635, A1011 SS Grade 33, A1011 HSLAS Grade 45, A653 Grade 33 or A36

### Pipe Clamps – Steel

A-1011 SS Grade 33

### Pipe Clamps – Stainless Steel

ASTM A-240, Type 304

### Pipe Clamps – Aluminum

ASTM B-209, 5052, H32 Grade, Sheet and Plate

### Channel Nuts

ASTM (1/4" & 5/16") A1011 SS Grade 33, (3/8", 7/16" & 1/2") A576 Grade 1015 Modified, (5/8" & 3/4") A36 or A675 Grade 60, (7/8") A36, Case hardened to RC25 min.

### Hex Nuts and Bolts

ASTM A-563, Grade A and ASTM A-307, Grade A

### Threaded Rod

Low Carbon Steel  
Yield = 32 ksi min.  
Tensile = 52 ksi min

\* Channel referenced is 1 5/8" wide, fittings referenced are for 1 5/8" channel.

† Some 1/4" fittings are produced from A-36 Structural Steel.

## Product Load Testing

Product testing is an important Part of Power-Strut's Quality Assurance Program. We utilize our own testing facilities, as well as those of independent testing laboratories, to determine design loads with proper and adequate safety factors. These design loads are indicated, where applicable, throughout the catalog. Loads are based on AISI Specification For The Design Of Cold-Formed Steel Structural Members, 2007 Edition.



Destructive and non-destructive testing procedures are used to test for variables such as corrosion, conductivity, electro-static dissipation, ultra-violet resistance, wind resistance, dimensional accuracy, material integrity and slip resistance.







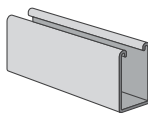
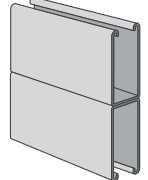
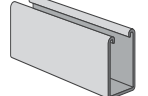
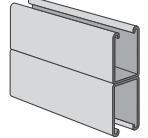
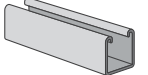
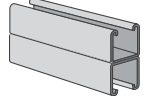
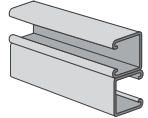
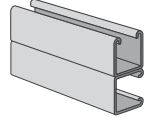
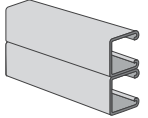
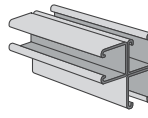
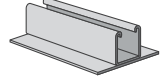
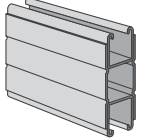
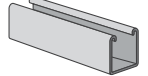
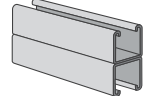
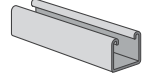
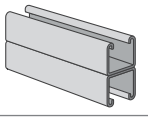
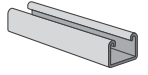
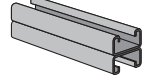
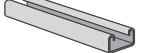
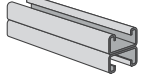
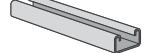
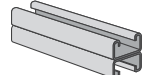
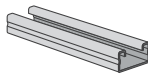
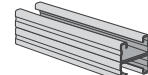
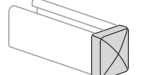
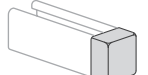





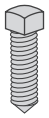



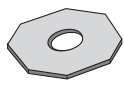

In short, if there's a specification to meet, Power-Strut will develop a test to quantify and verify it. Using design properties of the Power-Strut framing members, load data given in this catalog, and/or design procedures of the American Iron & Steel Institute Specification For The Design Of Cold-Formed Steel Structural Members, 2007 Edition, it is possible to design any type of structure within the capabilities of the system.

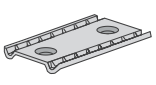
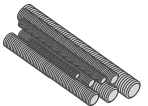
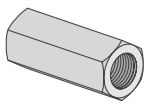
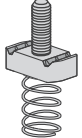
Assemblies or connections that cannot be calculated using provisions of the AISI specifications must be established by application-specific tests.

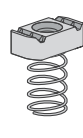
*We reserve the right to make specification changes without notice.*

*While every effort has been made to assure the accuracy of information contained in this catalog at the time of publication, we cannot accept responsibility for inaccuracies resulting from undetected errors or omissions.*

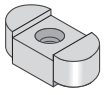
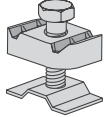
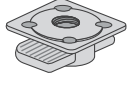
Channel						
						
PS 100 ..... 22	PS 100 2T3 ..... 22	PS 150 ..... 24	PS 150 2T3 ..... 24	PS 200 ..... 26	PS 200 2T3 ..... 26	PS 200 2T2 ..... 28
						
PS 200 2T4 ..... 28	PS 200 2T5 ..... 28	PS 200 3T6 ..... 28	PS 200 PLA ..... 29	PS 200 PLC ..... 29	PS 210 ..... 30	PS 210 2T3 ..... 30
						
PS 300 ..... 32	PS 300 2T3 ..... 32	PS 400 ..... 34	PS 400 2T3 ..... 34	PS 500 ..... 36	PS 500 2T3 ..... 36	PS 520 ..... 38
						
PS 520 2T3 ..... 38	PS 560 ..... 40	PS 560 2T3 ..... 40	PS 6152 ..... 42	PS 6153 ..... 42	PS 9050 ..... 42	

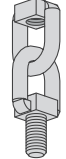
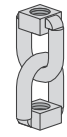
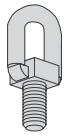
Fasteners						
						
PS 6024 ..... 45	PS 6072 ..... 45	PS 6075 ..... 45	PS 6064 ..... 45	PS 6108 ..... 45	PS 6112 ..... 45	PS 83 ..... 45
						
PS 209 ..... 45	PS 230 ..... 46	PS 231 ..... 46	PS 211 ..... 46	PS 3281 ..... 46	PS 146 ..... 46	PS 135 ..... 46
						
PS 517 ..... 46	PS LS ..... 47	PS RS ..... 47	PS SS ..... 47	PS NS ..... 47	PS NS S ..... 47	PS TG ..... 47
						
PS ML ..... 47	PS 3500 ..... 48	PS KW ..... 48	PS 202 ..... 48	PS 203 ..... 48	PS 204 ..... 48	PS 205 ..... 48

# PICTORIAL TABLE OF CONTENTS

## General Fittings

PS 601..... 50	PS 602..... 50	PS 617..... 50	PS 618..... 50	PS 619..... 50	PS 2504..... 50	PS 620..... 51
PS 621..... 51	PS 718..... 50	PS 719..... 50	PS 888..... 50	PS 889..... 50	PS 712..... 51	PS 714..... 51
PS 744..... 51	PS 750..... 51	PS 925..... 51	PS 2190..... 51	PS 747..... 51	PS 822..... 51	PS 854..... 51
PS 2112..... 51	PS 603..... 52	PS 921..... 52	PS 763..... 52	PS 764..... 52	PS 604..... 52	PS 2144..... 52
PS 806..... 52	PS 2520..... 52	PS 605..... 52	PS 606..... 53	PS 745..... 53	PS 2545..... 52	PS 607..... 53
PS 3049..... 53	PS 3373..... 53	PS 614..... 53	PS 615..... 53	PS 716 R or L..... 53	PS 720 R or L..... 53	PS 660..... 53
PS 927..... 54	PS 689 A & B..... 54	PS 713..... 53	PS 715..... 53	PS 622..... 54	PS 752 R or L..... 54	PS 746..... 54
PS 748..... 54	PS 3326 R or L..... 54	PS 2007 R or L..... 54	PS 633..... 55	PS 624..... 54	PS 781..... 55	PS 793..... 55
PS 2113..... 54	PS 9400..... 55	PS 9401..... 55	PS 9402..... 55	PS 9403..... 56	PS 9404..... 56	PS 926..... 54
PS 2054..... 55	PS 810..... 55	PS 812..... 56	PS 756..... 57	PS 2601..... 57	PS 611..... 57	PS 612..... 57

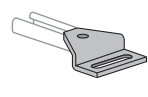
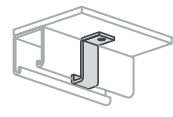
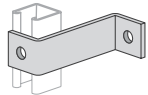
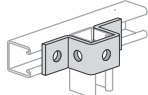
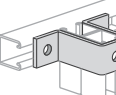
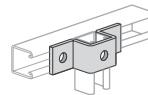
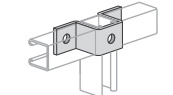
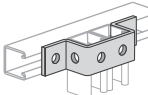
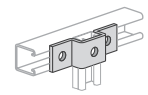
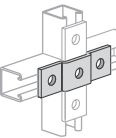
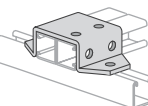
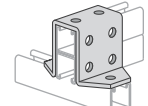
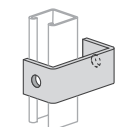
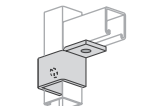
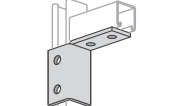
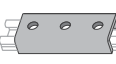
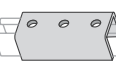
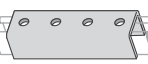
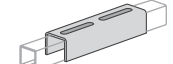
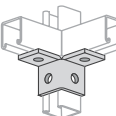
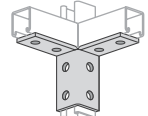
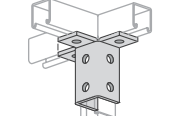
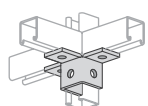
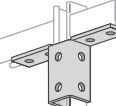
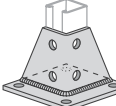
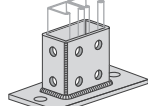
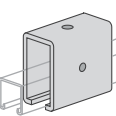
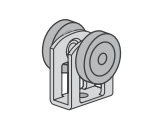
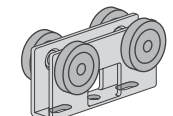
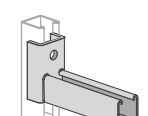
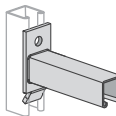
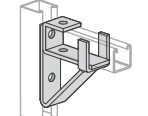
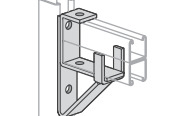
General Fittings (cont.)						
						
PS 711 ..... 57	PS 928 ..... 57	PS 609 ..... 57	PS 647 ..... 56	PS 692 ..... 56	PS 2523 ..... 56	PS 2532 ..... 56
						
PS 3060 ..... 56	PS 613 ..... 57	PS 679 ..... 57	PS 2648 ..... 57	PS 687A, B & C ..... 58	PS 710 ..... 57	PS 2119 ..... 57
						
PS 721 ..... 58	PS 929 ..... 58	PS 978 ..... 58	PS 709 ..... 58	PS 733 ..... 58	PS 678 ..... 58	PS 677 ..... 58
						
PS 734 ..... 58	PS 735 ..... 58	PS 623 ..... 58	PS 993 ..... 59	PS 922 R or L ..... 59	PS 2117 R or L ..... 59	PS 2128 R or L ..... 60
						
PS 631 ..... 59	PS 644 ..... 59	PS 645 ..... 59	PS 629 ..... 59	PS 516, PS 646 ..... 59	PS 804 ..... 59	PS 704 ..... 59
						
PS 1004 ..... 59	PS 2129 R or L ..... 60	PS 665 ..... 60	PS 666 ..... 60	PS 667 ..... 60	PS 2514 ..... 60	PS 670 ..... 61
						
PS 668 ..... 60	PS 821 ..... 60	PS 913 ..... 60	PS 923 ..... 60	PS 945 ..... 60	PS 669 ..... 61	PS 2514 ..... 60
						
PS 3013 & SQ ..... 61	PS 3025 & FL ..... 61	PS 3033 & SQ ..... 61	PS 3040 ..... 61	PS 2064 ..... 61	PS 3064 ..... 62	PS 3029 ..... 62
						
PS 3041 ..... 61	PS 2521 ..... 62	PS 2522 ..... 62	PS 2528 1 ..... 62	PS 2528 ..... 62	PS 2524 ..... 62	PS 2525 ..... 62
						
PS 626 ..... 63	PS 661 T1 & T2 ..... 63	PS 808 T1 & T2 ..... 63	PS 651 ..... 63	PS 809 ..... 63	PS 708 ..... 63	PS 3164 ..... 64

# PICTORIAL TABLE OF CONTENTS

General Fittings (cont.)						
PS 732..... 63	PS 838 R or L..... 64	PS 3282..... 64	PS 825 R or L..... 64	PS 826..... 64	PS 2404 thru PS 2408..... 64	PS 2421..... 65
PS 855..... 65	PS 2651..... 65	PS 2657..... 65	PS 2656..... 65	PS 685..... 65	PS 686..... 66	PS 2653..... 66
PS 907, PS 998..... 66	PS 916..... 66	PS 684..... 66	PS 2622..... 66	PS 736..... 66	PS 3201..... 67	PS 2624..... 66
PS 871..... 67	PS 858..... 67	PS 865..... 67	PS 2654 & A..... 68	PS 135X..... 67	PS 85..... 67	PS 95..... 68
PS 86..... 68	PS 93..... 68	PS 94..... 68				

Pipe & Conduit Clamps					
PS 1000.....70	PS 1100 Series.....70	PS 1300.....70	PS 1200.....71	PS 3138.....72	PS 3126.....72
PS 3792.....75	PS 67.....70	PS 69.....71	PS 137.....71	PS 51.....72	PS 004T.....74
PS 004M.....75	PS 270.....72	PS 52E.....75	PS MU.....76	PS TP.....73	PS CT.....73
PS UB.....76	PS 815.....77	PS 1911.....77	PS 816.....77	PS 1902.....78	PS 1901.....77

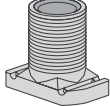
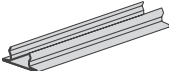
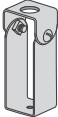
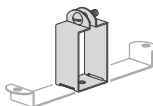
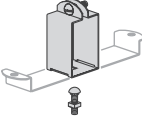
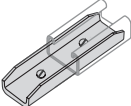
Electrical					
					
PS 655 Series .....84	PS 2511, PS 2581 .....84	PS 2560, PS 2561 .....84	PS 803 .....84	PS 2625 .....84	PS 707 .....84
					
PS 707P .....84	PS 2632 .....85	PS 2632D .....85	PS 2631 .....85	PS 2631D .....85	PS 3301 .....85
					
PS 807 .....85	PS 703 .....86	PS 2636 .....86	PS 2637 .....86	PS 702 .....86	PS 702 D .....86
					
PS 703 D .....86	PS 659 .....86	PS 658 .....86	PS 2621 .....87	PS 2639 .....87	PS 2662A .....87
					
PS 2660 .....87	PS 2661 .....87	PS 2094 .....87	PS 649 Series .....88	PS 760 .....89	PS 671 .....88
					
PS 2802 .....88	PS 2801 .....88	PS 2803 .....88	PS 2700 .....88	PS 2800 .....88	PS 791 .....89
					
PS 2627 .....89	PS 1510 .....89	PS 1500 .....89	PS 722 .....90	PS 1610 .....90	PS 1801 .....89

Concrete Inserts						
PS 349 ..... 92	PS 449 ..... 93	PS 656, PS 901 ..... 93	PS 653 ..... 92	PS 654 ..... 92	PS 1154 ..... 92	PS 6151 ..... 93
PS 3700 ..... 94						

Solar Components		
SLR 100 ..... 97	SLR 150 ..... 97	WEEB-WMC ..... 97

Unipier® Rooftop Support System					
Sleeper Support		Strut Support		Conduit Support	
RSS4 ..... 100-101		Model UP ..... 102,103		Mounted Poly. Base ..... 104	Elevated Support Poly. Base ..... 104
Gas and Mechanical Support			Accessories		
Mounted Poly. Base ..... 105	Mounted with Roller Poly. Base ..... 105	Elevated Support with Roller Poly. Base ..... 106	Elevated Support with Steel Base ..... 105	Spacer for Model 1.5, 3-R ..... 107	Support Pads & Deck Plates ..... 107
Pipe Hanger Bases		Fabricated Supports			
Poly. Bases ..... 108	Steel Bases ..... 108	Single Base Trapeze ..... 109	Double Base Trapeze ..... 110	Heavy Duty, Double Base Trapeze ..... 110	Double Base Duct Support ..... 111
Heavy Duty Mech. Support ..... 112	Light Duty Mech. Support ..... 112		Bridge Cross-Over, Walkway Service Platform or Ramp ..... 112		

Junior Channel							
PS 600J ..... 118	PS 700J ..... 119	PS 3017 ..... 118	PS 4017 ..... 118	PS 2013 ..... 119	PS 2014 ..... 119	PS 2015 ..... 119	PS 2016 ..... 119
PS 2033 ..... 119	PS 2034 ..... 119	PS 2008 ..... 120	PS 2017 ..... 120	PS 2018 ..... 120	PS 2025 ..... 120	PS 2037 ..... 120	PS 2019 ..... 120
PS 2024 ..... 120	PS 2023 R/L ..... 120	PS 2010 ..... 120	PS 2026 ..... 120	PS 2011 ..... 120	PS 2029 ..... 118	PS 2041 ..... 120	

Power-Angle®						
PA 158 ..... 122-126	PA 238 ..... 122-126	PA 318 ..... 122-126	PA 1SNB ..... 122			

Fiberglass Aickinstrut®						
20P-2000, 20V-2000 & 20E-2000 ..... 133	20P-2200, 20V-2200 & 20E-2200 ..... 133	20P-2300, 20V-2300 & 20E-2300 ..... 133	20P-2100, 20V-2100 ..... 133	20P-1500, 20V-1500 ..... 133	20P-1700, 20V-1700 ..... 133	20P-1800, 20V-1800 ..... 133
20P-1600, 20V-1600 ..... 133	20P-1000, 20V-1000, 20E-1000 ..... 133	20P-1200, 20V-1200, 20E-1200 ..... 133	20P-1300, 20V-1300, 20E-1300 ..... 133	20P-1100, 20V-1100 ..... 133	20P-2000-SST, 20V-2000-SST ..... 133	20P-2200-SST, 20V-2200-SST ..... 133
20P-2300-SST, 20V-2300-SST ..... 133	20P-2100-SST, 20V-2100-SST ..... 133	20P/V-2500, 20P/V-2800 ..... 136	20P/V-2502, 20P/V-2802 ..... 136	20P/V-2504, 20P/V-2804 ..... 136	20P/V-2506, 20P/V-2806 ..... 136	50PU-2616 ..... 136
20P/V-2508, 20P/V-2808 ..... 136	20P/V-2510, 20P/V-2810R, 20P/V-2810L ..... 136	20P/V-2512, 20P/V-2812 ..... 136	20P/V-2514, 20P/V-2814 ..... 136	20P/V-2516, 20P/V-2816R, 20P/V-2816L ..... 137	20P/V-2518, 20P/V-2818 ..... 137	20P/V-2520, 20P/V-2820 ..... 137



## Fiberglass Aickinstrut® (cont.)

20P/V-2522, 20P/V-2822 ..... 137	20P/V-2524, 20P/V-2824 ..... 137	20P/V-2526, 20P/V-2826 ..... 137	20P/V-2528, 20P/V-2828 ..... 137	20P/V-2530, 20P/V-2830 ..... 137	20P/V-2534, 20P/V-2834 ..... 137	20P-2541, 20V-2541 ..... 137
20P/V-2540, 20P/V-2840 ..... 137	50PU-2611 ..... 137	20P-2542, 20V-2542 ..... 138	50PU-2611-SP ..... 138	50PU-2613 ..... 138	50PU-1528, 50PU-1508 ..... 138	50PU-2045 ..... 138
50PU-2090 ..... 138	50PU-2636, 50PU-2636A, 50PU-3636B, 50PU-2936 ..... 138	50PU-2538 ..... 138	20PU-5853, 20PU-5854, 20PU-5855, 20PP-5853, 20PP-5854, 20PP-5855.. 138	20PU-5903, 20PU-5904, 20PU-5905, 20PP-5903, 20PP-5904, 20PP-5905.. 138	Adjustable Pipe Clamp ..... 139	50PU-500SP ..... 139
Rigid Pipe Clamps ..... 140	Two-Hole Pipe Straps ..... 140	Aickin-A-Grip ..... 141	20E-5000 ..... 141	AIC-EC ..... 141	Nonmetallic U-Bolts ..... 142	Hex Flange Bolts. 142
Hex Bolts ..... 142	Hex Nuts ..... 143	Hex Flange Nuts.. 143	Vinyl Ester Square Head Bolts ..... 143	Flat Washers ..... 143	All-Thread Washers ..... 143	Heavy Duty Channel Nuts ..... 144
Standard Duty Channel Nuts ..... 144	Saddle Clips ..... 144	Stop-Lock Assemblies ..... 144	Fabricated Beam Clamps ..... 144	Molded Clevis Hanger ..... 145	Hand Lay-Up Clevis Hangers ..... 145	Molded Beam Clamps ..... 145
Cope-Glas Beam Clamps ..... 145	Beam Clip ..... 145	Threaded Rod ..... 146	Rod Couplers ..... 146	Duraclamp ..... 146	Channel Hangers ..... 146	Power-Rack Stanchions ..... 147
Wall Brackets ..... 147	Heavy Duty Post Base ..... 148	Stands ..... 148				

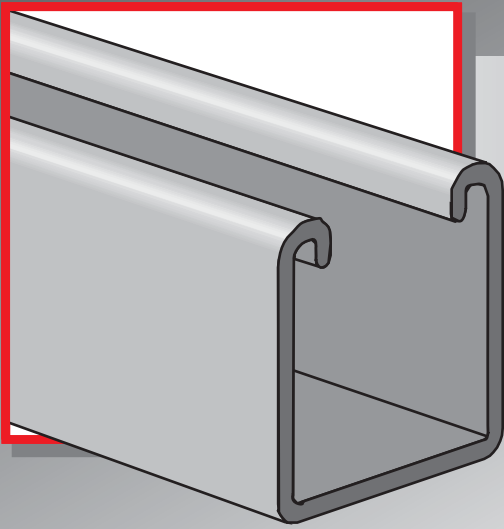

# CHANNEL

*Power-Strut channel sections are produced by multiple sets of forming rolls which cold-work strip steel into the channel configuration. This type of roll forming produces a uniform channel section held to the specifications of MFMA-4.*

## **MATERIALS:**

Plain and painted green channels are formed from structural quality strip steel which conforms to the requirements of ASTM A-1011 SS Grade 33. Pre-galvanized channel conforms to the requirements of ASTM A-653 Grade 33. Stainless steel available upon request.

## **STANDARD LENGTHS:**

Stock lengths are 10 and 20 feet. Special lengths are available upon request.

## **STANDARD FINISHES:**

Standard Power-Strut channel is available in plain, painted green, Zinc dichromate, Hot-dip galvanized or pre-galvanized finishes.

## **ORDERING INFORMATION:**

When ordering, add the length or size and finish to the part number. See page 8 - 9 for finish abbreviations and an example.

Type of Load	Safety Factor to Yield Strength
Beam Loads	1.67
Column Load	1.80

**PS 100** – 1<sup>5</sup>/<sub>8</sub>" x 3<sup>1</sup>/<sub>4</sub>" x 12 ga.

*See Pages 22-23*

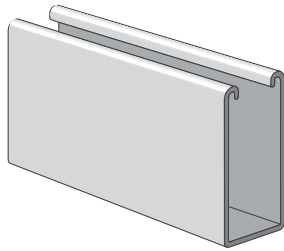

**PS 210** – 1<sup>5</sup>/<sub>8</sub>" x 1<sup>5</sup>/<sub>8</sub>" x 14 ga.

*See Pages 30-31*

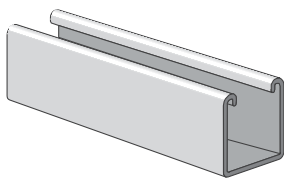

**PS 500** – 1<sup>5</sup>/<sub>8</sub>" x 1<sup>3</sup>/<sub>16</sub>" x 14 ga.

*See Pages 36-37*

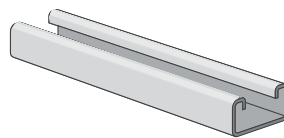

**PS 600J** – 1<sup>3</sup>/<sub>16</sub>" x 1<sup>3</sup>/<sub>16</sub>" x 19 ga.

*See Junior Channel Page 124*

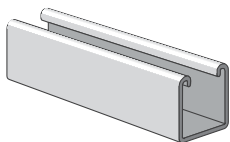

**PS 700J** – 1<sup>3</sup>/<sub>16</sub>" x 1<sup>3</sup>/<sub>32</sub>" x 19 ga.

*See Junior Channel Page 125*

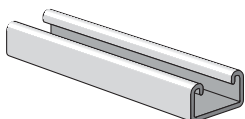

**PS 150** – 1<sup>5</sup>/<sub>8</sub>" x 2<sup>7</sup>/<sub>16</sub>" x 12 ga.

*See Pages 24-25*

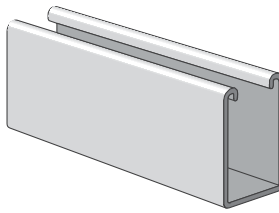

**PS 300** – 1<sup>5</sup>/<sub>8</sub>" x 1<sup>3</sup>/<sub>8</sub>" x 12 ga.

*See Pages 32 -33*

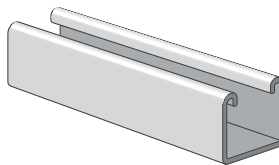

**PS 520** – 1<sup>5</sup>/<sub>8</sub>" x 1<sup>3</sup>/<sub>16</sub>" x 12 ga.

*See Pages 38-39*

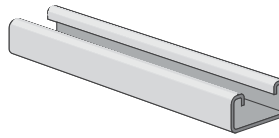

**PS 200** – 1<sup>5</sup>/<sub>8</sub>" x 1<sup>5</sup>/<sub>8</sub>" x 12 ga.

*See Pages 26-29*

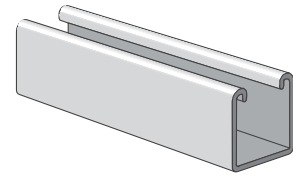

**PS 400** – 1<sup>5</sup>/<sub>8</sub>" x 1" x 12 ga.

*See Pages 34-35*

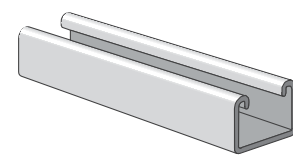

**PS 560** – 1<sup>5</sup>/<sub>8</sub>" x 1<sup>3</sup>/<sub>16</sub>" x 16 ga.

*See Pages 40-41*

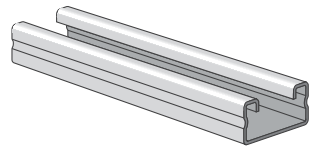

## Maximum Allowable Pull-Out and Slip Loads

Channel Nut Size-Thread	Allowable Gauge Channel	Pull-Out Strength (Lbs.)	Resistance to Slip (Lbs.)	Torque Ft.-Lbs.
3/4"-10	12 Gauge PS 100 PS 150 PS 200 PS 300	2,500	1,700	*125
5/8"-11		2,500	1,500	*100
1/2"-13		2,000	1,500	50
7/16"-14		1,400	1,000	35
3/8"-16		1,000	800	19
5/16"-18		800	500	11
1/4"-20		600	300	6
1/2"-13	12 Gauge PS 400 PS 520	1,500	1,500	50
3/8"-16		1,000	800	19
5/16"-18		800	500	11
1/4"-20		600	300	6
1/2"-13	14 Gauge PS 210 PS 500	1,400	1,000	50
3/8"-16		1,000	750	19
5/16"-18		800	400	11
1/4"-20		600	300	6
1/2"-13	16 Gauge PS 560	1,000	1,000	50
3/8"-16		1,000	750	19
5/16"-18		800	400	11
1/4"-20		600	300	6

\* May require 3/8" or 1/2" thick fitting.

Nut design loads include a minimum safety factor of 3.

Note: Refer to the Channel Nut Selection Chart on page 44 for the part number

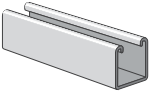

**Channel with Holes (H)**

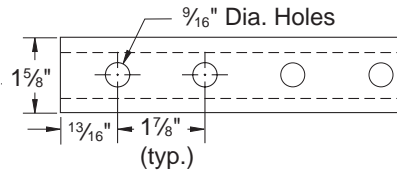
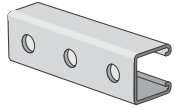

Available With These Select Channel Types:												
PS 100	PS 150	PS 150 2T3	PS 200	PS 200 2T3	PS 210	PS 300	PS 300 2T3	PS 400	PS 500	PS 500 2T3	PS 520	PS 560
■	■		■		■	■		■	■		■	

**Channel with Holes on Three Sides (H3)**

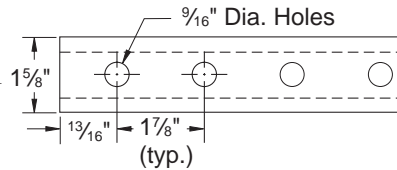
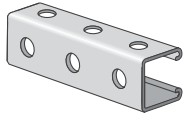

Available With These Select Channel Types:												
PS 100	PS 150	PS 150 2T3	PS 200	PS 200 2T3	PS 210	PS 300	PS 300 2T3	PS 400	PS 500	PS 500 2T3	PS 520	PS 560
			■									

**Channel with Slots (S)**

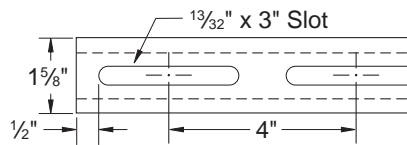
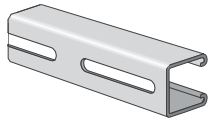

Available With These Select Channel Types:												
PS 100	PS 150	PS 150 2T3	PS 200	PS 200 2T3	PS 210	PS 300	PS 300 2T3	PS 400	PS 500	PS 500 2T3	PS 520	PS 560
■	■		■		■	■		■	■		■	■

**Channel with Elongated Holes (EH)**

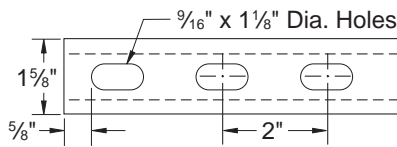
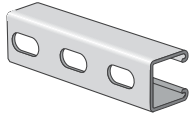

Available With These Select Channel Types:												
PS 100	PS 150	PS 150 2T3	PS 200	PS 200 2T3	PS 210	PS 300	PS 300 2T3	PS 400	PS 500	PS 500 2T3	PS 520	PS 560
■	■	■	■	■	■	■	■	■	■	■	■	■

**Channel with Knockouts (KO6)**

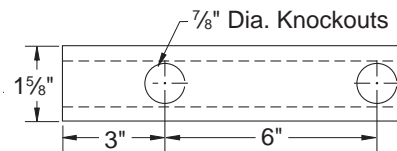
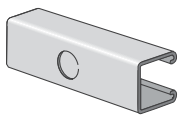

Available With These Select Channel Types:												
PS 100	PS 150	PS 150 2T3	PS 200	PS 200 2T3	PS 210	PS 300	PS 300 2T3	PS 400	PS 500	PS 500 2T3	PS 520	PS 560
■	■		■		■							

**Channel with Slotted Back (SB)**

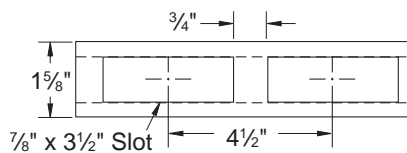
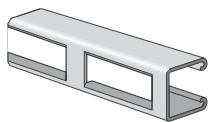

Available With These Select Channel Types:												
PS 100	PS 150	PS 150 2T3	PS 200	PS 200 2T3	PS 210	PS 300	PS 300 2T3	PS 400	PS 500	PS 500 2T3	PS 520	PS 560
			■									

**Channel with Wide Slots (WT)**

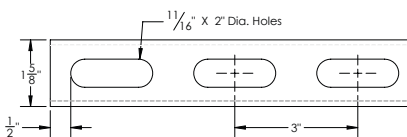
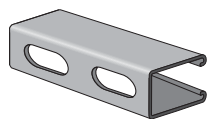

Available With These Select Channel Types:												
PS 100	PS 150	PS 150 2T3	PS 200	PS 200 2T3	PS 210	PS 300	PS 300 2T3	PS 400	PS 500	PS 500 2T3	PS 520	PS 560
■	■	■	■	■	■	■	■	■	■	■	■	■

# CHANNEL

**Finish:** Plain, Painted Green, Zinc dichromate, Hot-dip galvanized or Pregalvanized **Order By:** No., Length and Finish

**PS 100 - Steel Channel (1 5/8" x 3 1/4" x 12 ga.)**

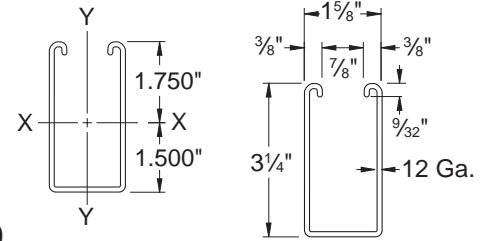
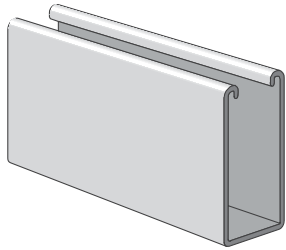

ELEMENTS OF SECTION - PS 100

Weight (lbs./100 ft.)	Area of Section (Inch <sup>2</sup> )	X-X Axis			Y-Y Axis		
		Moment of Inertia (Inch <sup>4</sup> )	Section Modulus (Inch <sup>3</sup> )	Radius of Gyration (Inch)	Moment of Inertia (Inch <sup>4</sup> )	Section Modulus (Inch <sup>3</sup> )	Radius of Gyration (Inch)
305	0.897	1.098	0.627	1.107	0.433	0.533	0.695

**PS 100 H - Channel with Holes**

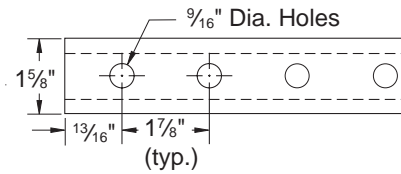
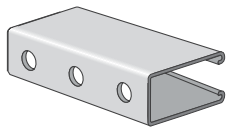

Weight: 300 lbs./100 ft.

**PS 100 EH - Channel with Elongated Holes**

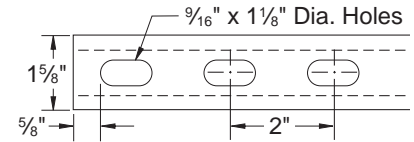
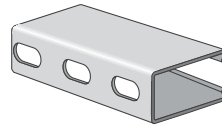

Weight: 300 lbs./100 ft.

**PS 100 S - Channel with Slots**

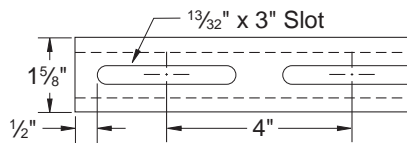
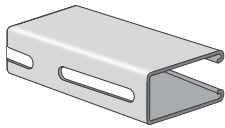

Weight: 300 lbs./100 ft.

**PS 100 K06 - Channel with Knockouts**

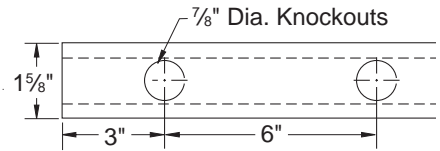
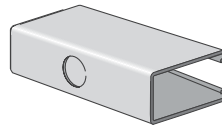

Weight: 305 lbs./100 ft.

**PS 100 2T3 - Steel Channel (1 5/8" x 6 1/2" x 12 ga.)**

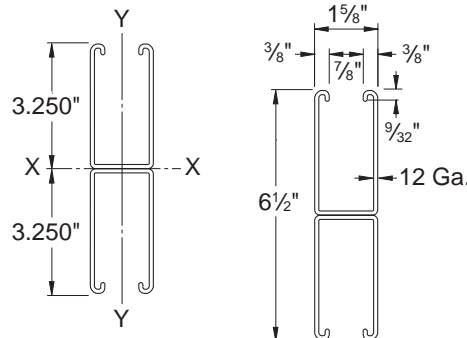
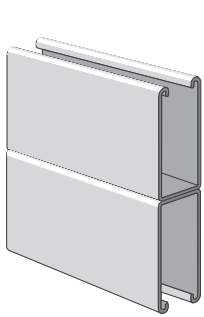

ELEMENTS OF SECTION - PS 100 2T3

Weight (lbs./100 ft.)	Area of Section (Inch <sup>2</sup> )	X-X Axis			Y-Y Axis		
		Moment of Inertia (Inch <sup>4</sup> )	Section Modulus (Inch <sup>3</sup> )	Radius of Gyration (Inch)	Moment of Inertia (Inch <sup>4</sup> )	Section Modulus (Inch <sup>3</sup> )	Radius of Gyration (Inch)
610	1.793	6.226	1.916	1.864	0.866	1.066	0.695

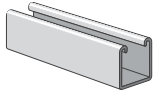

Finish: Plain, Painted Green, Zinc dichromate, Hot-dip galvanized or Pregalvanized **Order By:** No., Length and Finish

**PS 100 & PS 100 2T3 - Load Data**

**BEAM LOADING - PS 100**

Span (in)	Max Allowable Uniform Load (lb)	Defl. at Uniform Load (in)	Uniform Loading at Deflection		
			Span/180 (lbs)	Span/240 (lbs)	Span/360 (lbs)
24	5,260	0.03	5,260	5,260	5,260
36	3,500	0.07	3,500	3,500	3,500
48	2,630	0.12	2,630	2,630	2,630
60	2,100	0.18	2,100	2,100	1,920
72	1,750	0.26	1,750	1,750	1,330
84	1,500	0.36	1,500	1,470	980
96	1,310	0.47	1,310	1,120	750
108	1,170	0.59	1,170	890	590
120	1,050	0.73	960	720	480
144	880	1.06	670	500	330
168	750	1.43	490	370	240
192	660	1.88	370	280	190
216	580	2.35	300	220	150
240	530	2.95	240	180	120

\* Bearing load may govern capacity.

For concentrated load at center of span, divide uniform load by 2 and multiply corresponding deflection by 0.8. This load table is based on a solid channel section.

Loads include weight of channel, which must be deducted.

Loads must be multiplied by the applicable unbraced factor from page 42.

For Pierced Channels, reduce beam load values as follows:

PS-100-EH	15%	PS-100-S	15%
PS-100-H	10%	PS-100-K06	5%
PS-100-WT	15%		

**COLUMN LOADING - PS 100**

Unbraced Height (in)	Max. Allowable Load at Slot Face (lbs)	Maximum Column Load Applied at C.G.			
		K = 0.65 (lbs)	K = 0.80 (lbs)	K = 1.0 (lbs)	K = 1.2 (lbs)
24	5,650	16,870	15,180	12,850	10,600
36	4,690	13,140	10,600	7,650	5,660
48	3,560	9,550	6,860	4,790	3,660
60	2,730	6,680	4,790	3,450	2,710
72	2,160	4,980	3,660	2,710	2,170
84	1,760	3,950	2,960	2,240	1,820
96	1,500	3,270	2,500	1,930	1,580
108	1,310	2,800	2,170	1,690	1,390
120	1,170	2,450	1,930	1,510	**
144	980	1,980	1,580	**	**
168	850	1,670	1,340	**	**

\*\*  $K_L > 200$

Column loads are for allowable axial loads and must be reduced for eccentric loading.

**PS100 - Crush Loads**

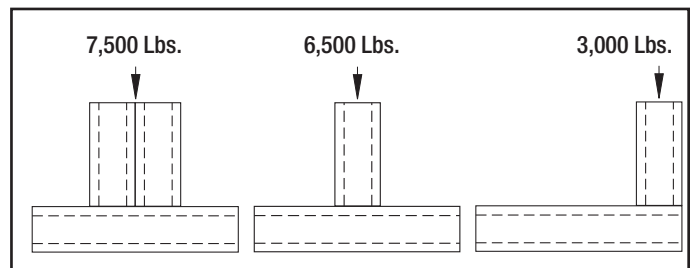

Resistance to Slip - 1,500 lbs. per bolt when 1/2" PS NS channel nuts are used.

Pull Out Strength - 2,000 lbs. per bolt when 1/2" PS NS channel nuts are used.

**BEAM LOADING - PS 100 2T3**

Span (in)	Max Allowable Uniform Load (lb)	Defl. at Uniform Load (in)	Uniform Loading at Deflection		
			Span/180 (lbs)	Span/240 (lbs)	Span/360 (lbs)
24	6,890 *	0.01	6,890 *	6,890 *	6,890 *
36	6,890 *	0.02	6,890 *	6,890 *	6,890 *
48	6,890 *	0.05	6,890 *	6,890 *	6,890 *
60	6,420	0.10	6,420	6,420	6,420
72	5,350	0.14	5,350	5,350	5,350
84	4,590	0.19	4,590	4,590	4,590
96	4,020	0.25	4,020	4,020	4,020
108	3,570	0.32	3,570	3,570	3,360
120	3,210	0.39	3,210	3,210	2,720
144	2,680	0.57	2,680	2,680	1,890
168	2,290	0.77	2,290	2,080	1,390
192	2,010	1.01	2,010	1,590	1,060
216	1,780	1.27	1,680	1,260	840
240	1,610	1.58	1,360	1,020	680

\* Load limited by spot weld shear.

† Bearing load may govern capacity.

For concentrated load at center of span, divide uniform load by 2 and multiply corresponding deflection by 0.8.

Loads include weight of channel, which must be deducted.

Loads must be multiplied by the applicable unbraced factor from page 42.

**COLUMN LOADING - PS 100 2T3**

Unbraced Height (in)	Max. Allowable Load at Slot Face (lbs)	Maximum Column Load Applied at C.G.			
		K = 0.65 (lbs)	K = 0.80 (lbs)	K = 1.0 (lbs)	K = 1.2 (lbs)
24	10,670	39,230	38,030	36,210	34,240
36	10,350	36,450	34,240	31,200	28,260
48	9,940	33,220	30,200	26,430	23,190
60	9,290	29,950	26,430	22,470	19,380
72	8,560	26,880	23,190	19,380	16,450
84	7,860	24,140	20,520	17,040	12,090
96	7,220	21,790	18,370	13,330	9,250
108	6,600	19,790	16,450	10,530	7,310
120	5,760	18,130	13,330	8,530	**
144	4,390	14,020	9,250	**	**
168	3,420	10,300	6,800	**	**

\*\*  $K_L > 200$

Column loads are for allowable axial loads and must be reduced for eccentric loading.

# CHANNEL

**Finish:** Plain, Painted Green, Zinc dichromate, Hot-dip galvanized or Pregalvanized **Order By:** No., Length and Finish

**PS 150 – Steel Channel (1<sup>5</sup>/<sub>8</sub>" x 2<sup>7</sup>/<sub>16</sub>" x 12 ga.)**

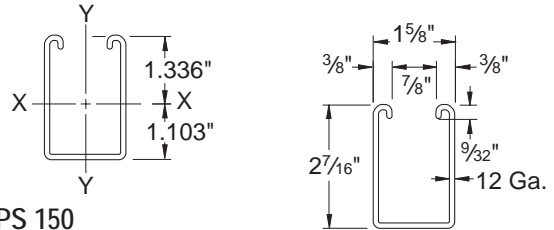
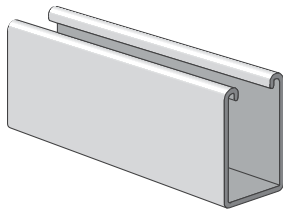

ELEMENTS OF SECTION – PS 150

Weight (lbs./100 ft.)	Area of Section (Inch <sup>2</sup> )	X-X Axis			Y-Y Axis		
		Moment of Inertia (Inch <sup>4</sup> )	Section Modulus (Inch <sup>3</sup> )	Radius of Gyration (Inch)	Moment of Inertia (Inch <sup>4</sup> )	Section Modulus (Inch <sup>3</sup> )	Radius of Gyration (Inch)
247	0.726	0.522	0.390	0.848	0.334	0.411	0.679

**PS 150 H – Channel with Holes**

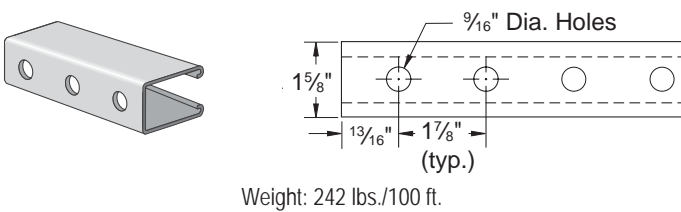

**PS 150 EH – Channel with Elongated Holes**

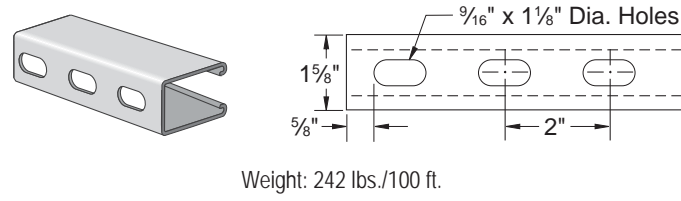

**PS 150 S – Channel with Slots**

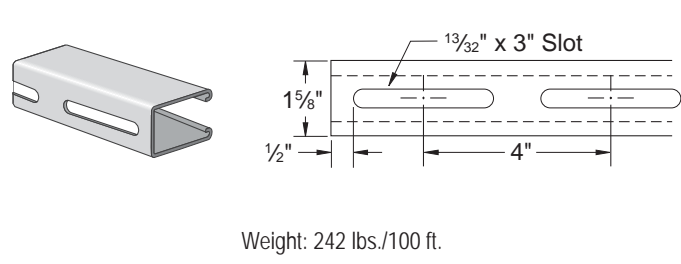

**PS 150 K06 – Channel with Knockouts**

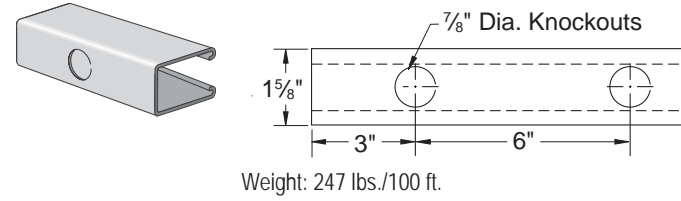

**PS 150 2T3 – Steel Channel (1<sup>5</sup>/<sub>8</sub>" x 4<sup>7</sup>/<sub>8</sub>" x 12 ga.)**

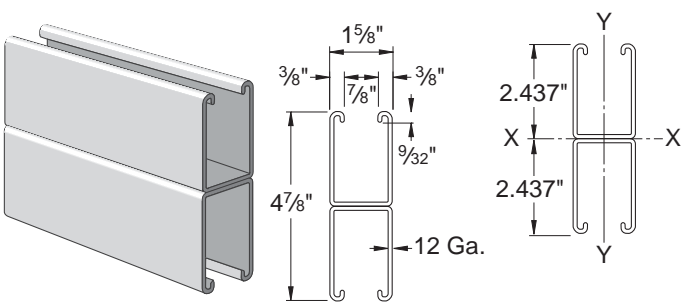

**PS 150 2T3 EH – Channel with Elongated Holes**

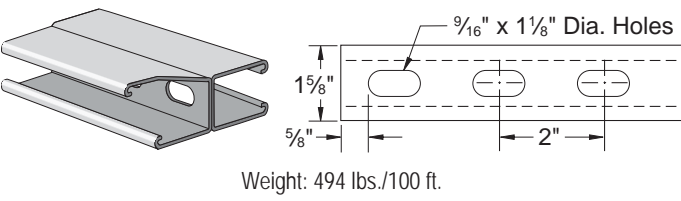

**PS 150 WT – Channel with Wide Slots**

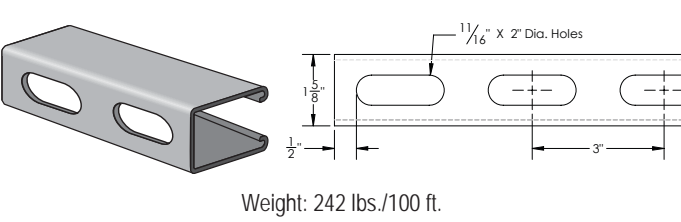

ELEMENTS OF SECTION – PS 150 2T3

Weight (lbs./100 ft.)	Area of Section (Inch <sup>2</sup> )	X-X Axis			Y-Y Axis		
		Moment of Inertia (Inch <sup>4</sup> )	Section Modulus (Inch <sup>3</sup> )	Radius of Gyration (Inch)	Moment of Inertia (Inch <sup>4</sup> )	Section Modulus (Inch <sup>3</sup> )	Radius of Gyration (Inch)
494	1.452	2.805	1.151	1.390	0.669	0.823	0.679

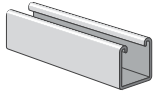

Finish: Plain, Painted Green, Zinc dichromate, Hot-dip galvanized or Pregalvanized **Order By:** No., Length and Finish

**PS 150 & PS 150 2T3 - Load Data**

**BEAM LOADING - PS 150**

Span (in)	Max Allowable Uniform Load (lb)	Defl. at Uniform Load (in)	Uniform Loading at Deflection		
			Span/180 (lbs)	Span/240 (lbs)	Span/360 (lbs)
24	3,270	0.04	3,270	3,270	3,270
36	2,180	0.09	2,180	2,180	2,180
48	1,640	0.15	1,640	1,640	1,420
60	1,310	0.24	1,310	1,310	910
72	1,090	0.34	1,090	950	630
84	940	0.47	930	700	470
96	820	0.61	710	530	360
108	730	0.78	560	420	280
120	650	0.95	460	340	230
144	550	1.39	320	240	160
168	470	1.89	230	170	120
192	410	2.46	180	130	90
216	360	3.07	140	110	70
240	330	3.86	110	90	60

\* Bearing load may govern capacity.

This load table is based on a solid channel section.

For concentrated load at center of span, divide uniform load by 2 and multiply corresponding deflection by 0.8.

Loads include weight of channel, which must be deducted.

Loads must be multiplied by the applicable unbraced factor from page 42.

For Pierced Channels, reduce beam load values as follows:

- PS-150-EH 15%
- PS-150-S 15%
- PS-150-H 10%
- PS-150-K06 5%
- PS-150-WT 15%

**COLUMN LOADING - PS 150**

Unbraced Height (in)	Max. Allowable Load at Slot Face (lbs)	Maximum Column Load Applied at C.G.			
		K = 0.65 (lbs)	K = 0.80 (lbs)	K = 1.0 (lbs)	K = 1.2 (lbs)
24	4,640	13,840	12,570	10,840	9,190
36	3,970	11,050	9,190	7,030	5,370
48	3,180	8,420	6,390	4,620	3,630
60	2,550	6,250	4,620	3,450	2,780
72	2,120	4,790	3,630	2,780	2,260
84	1,810	3,890	3,010	2,330	1,910
96	1,580	3,290	2,580	2,020	1,650
108	1,400	2,860	2,260	1,770	1,440
120	1,270	2,530	2,020	1,580	**
144	1,060	2,070	1,650	**	**
168	920	1,750	1,380	**	**

\*\*  $K_L > 200$

Column loads are for allowable axial loads and must be reduced for eccentric loading.

**PS150 - Crush Loads**

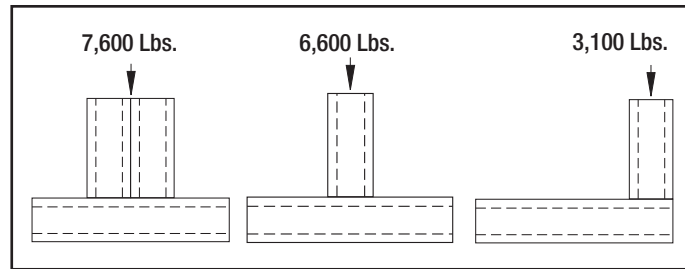

Resistance to Slip - 1,500 lbs. per bolt when 1/2" PS NS channel nuts are used.  
Pull Out Strength - 2,000 lbs. per bolt when 1/2" PS NS channel nuts are used.

**BEAM LOADING - PS 150 2T3**

Span (in)	Max Allowable Uniform Load (lb)	Defl. at Uniform Load (in)	Uniform Loading at Deflection		
			Span/180 (lbs)	Span/240 (lbs)	Span/360 (lbs)
24	5,220 *	0.01	5,220 *	5,220 *	5,220 *
36	5,220 *	0.04	5,220 *	5,220 *	5,220 *
48	4,820	0.08	4,820	4,820	4,820
60	3,860	0.13	3,860	3,860	3,860
72	3,220	0.19	3,220	3,220	3,220
84	2,760	0.26	2,760	2,760	2,500
96	2,410	0.34	2,410	2,410	1,920
108	2,140	0.42	2,140	2,140	1,510
120	1,930	0.52	1,930	1,840	1,230
144	1,610	0.76	1,610	1,280	850
168	1,380	1.03	1,250	940	630
192	1,210	1.35	960	720	480
216	1,070	1.70	760	570	380
240	960	2.09	610	460	310

\*Load limited by spot weld shear.

For concentrated load at center of span, divide uniform load by 2 and multiply corresponding deflection by 0.8.

Loads include weight of channel, which must be deducted.

Loads must be multiplied by the applicable unbraced factor from page 42.

**COLUMN LOADING - PS 150 2T3**

Unbraced Height (in)	Max. Allowable Load at Slot Face (lbs)	Maximum Column Load Applied at C.G.			
		K = 0.65 (lbs)	K = 0.80 (lbs)	K = 1.0 (lbs)	K = 1.2 (lbs)
24	8,580	31,810	30,880	29,520	28,100
36	8,350	29,700	28,100	26,000	24,070
48	8,080	27,390	25,330	22,910	20,940
60	7,720	25,170	22,910	20,510	17,170
72	7,270	23,190	20,940	17,170	12,700
84	6,780	21,510	18,740	13,430	9,330
96	6,130	20,110	15,630	10,290	7,150
108	5,450	17,750	12,700	8,130	5,650
120	4,800	15,260	10,290	6,590	**
144	3,760	10,830	7,150	**	**
168	2,970	7,950	5,250	**	**

\*\*  $K_L > 200$

Column loads are for allowable axial loads and must be reduced for eccentric loading.

For Pierced Channels, reduce beam load values as follows:

- PS-150 2T3-EH 15%

Metal Channel  
Fasteners  
Fittings  
Pipe & Conduit Clamps  
Electrical  
Concrete Inserts  
Solar Components  
Unipier®  
Jr. Channel  
Power-Angle  
Fiberglass  
Tech. Data



# CHANNEL

**Finish:** Plain, Painted Green, Zinc dichromate, Hot-dip galvanized or Pregalvanized **Order By:** No., Length and Finish

## PS 200 - Steel Channel (1 5/8" x 1 5/8" x 12 ga.)

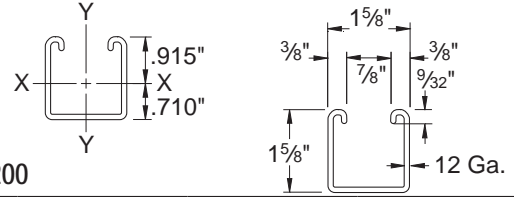
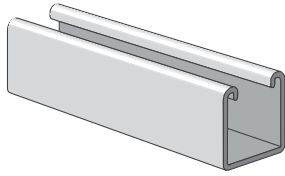

ELEMENTS OF SECTION - PS 200

Weight (lbs./100 ft.)	Area of Section (Inch <sup>2</sup> )	X-X Axis			Y-Y Axis		
		Moment of Inertia (Inch <sup>4</sup> )	Section Modulus (Inch <sup>3</sup> )	Radius of Gyration (Inch)	Moment of Inertia (Inch <sup>4</sup> )	Section Modulus (Inch <sup>3</sup> )	Radius of Gyration (Inch)
189	0.555	0.185	0.202	0.577	0.236	0.290	0.651

### PS 200 H - Channel with Holes

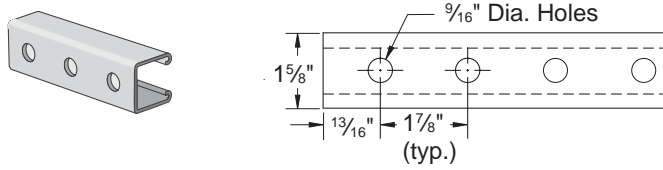

Weight: 186 lbs./100 ft.

### PS 200 EH - Channel with Elongated Holes

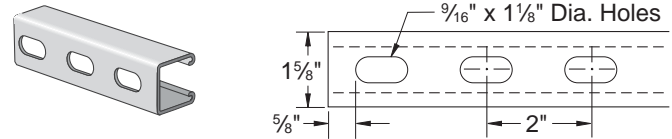

Weight: 185 lbs./100 ft.

### PS 200 H3 - Channel with Holes

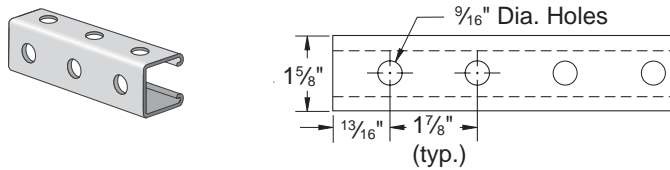

Weight: 175 lbs./100 ft.

### PS 200 K06 - Channel with Knockouts

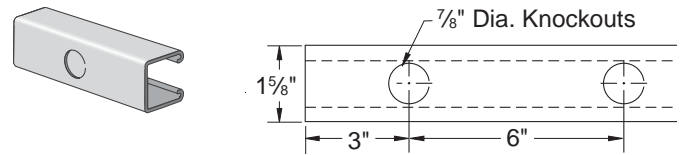

Weight: 189 lbs./100 ft.

### PS 200 S - Channel with Slots

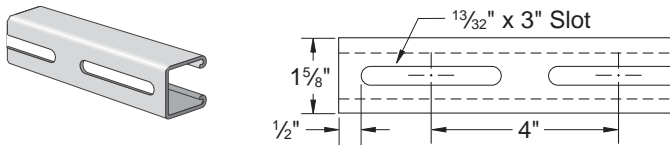

Weight: 185 lbs./100 ft.

### PS 200 SB - Channel with Slotted Back

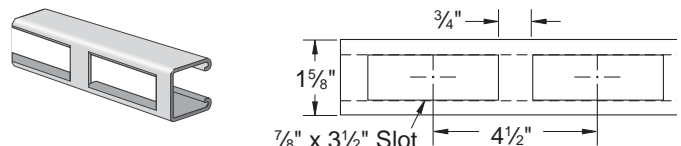

Weight: 173 lbs./100 ft.

### PS 200 2T3 - Steel Channel (1 5/8" x 3 1/4" x 12 ga.)

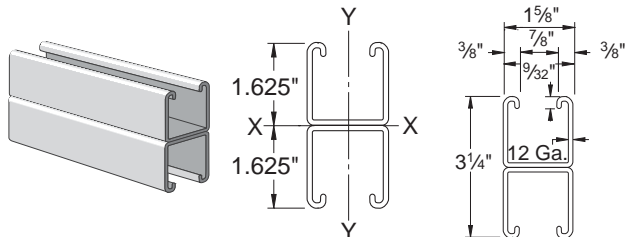

ELEMENTS OF SECTION - PS 200 2T3

Weight (lbs./100 ft.)	Area of Section (Inch <sup>2</sup> )	X-X Axis			Y-Y Axis		
		Moment of Inertia (Inch <sup>4</sup> )	Section Modulus (Inch <sup>3</sup> )	Radius of Gyration (Inch)	Moment of Inertia (Inch <sup>4</sup> )	Section Modulus (Inch <sup>3</sup> )	Radius of Gyration (Inch)
378	1.111	0.928	0.571	0.914	0.471	0.580	0.651

### PS 200 WT - Channel with Wide Slots

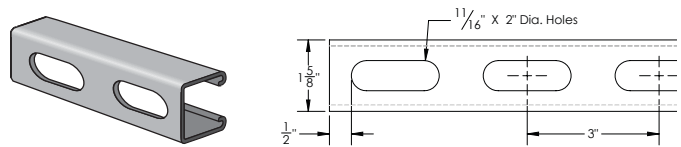

Weight: 185 lbs./100 ft.

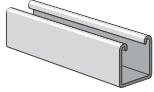

Finish: Plain, Painted Green, Zinc dichromate, Hot-dip galvanized or Pregalvanized **Order By:** No., Length and Finish

**PS 200 & PS 200 2T3 - Load Data**

**BEAM LOADING – PS 200**

Span (in)	Max Allowable Uniform Load (lb)	Defl. at Uniform Load (in)	Uniform Loading at Deflection		
			Span/180 (lbs)	Span/240 (lbs)	Span/360 (lbs)
24	1,690	0.06	1,690	1,690	1,690
36	1,130	0.13	1,130	1,130	900
48	850	0.22	850	760	500
60	680	0.35	650	480	320
72	560	0.50	450	340	220
84	480	0.68	330	250	160
96	420	0.89	250	190	130
108	380	1.14	200	150	100
120	340	1.40	160	120	80
144	280	2.00	110	80	60
168	240	2.72	80	60	40
192	210	3.55	60	50	NR
216	190	4.58	50	40	NR
240	170	5.62	40	NR	NR

\* Bearing load may govern capacity.

NR - Not Recommended

This load table is based on a solid channel section.

For concentrated load at center of span, divide uniform load by 2 and multiply corresponding deflection by 0.8.

Loads include weight of channel, which must be deducted.

Loads must be multiplied by the applicable unbraced factor from page 42.

For Pierced Channels, reduce beam load values as follows:

PS-200-EH	15%	PS-200-S	15%
PS-200-H	10%	PS-200-K06	5%
PS-200-SB	30%	PS-200-WT	15%

For Extruded Aluminum Channels, reduce beam load values 38%.

**COLUMN LOADING – PS 200**

Unbraced Height (in)	Max. Allowable Load at Slot Face (lbs)	Maximum Column Load Applied at C.G.			
		K = 0.65 (lbs)	K = 0.80 (lbs)	K = 1.0 (lbs)	K = 1.2 (lbs)
24	3,550	10,740	9,890	8,770	7,740
36	3,190	8,910	7,740	6,390	5,310
48	2,770	7,260	6,010	4,690	3,800
60	2,380	5,910	4,690	3,630	2,960
72	2,080	4,840	3,800	2,960	2,400
84	1,860	4,040	3,200	2,480	1,980
96	1,670	3,480	2,750	2,110	1,660
108	1,510	3,050	2,400	1,810	**
120	1,380	2,700	2,110	**	**
144	1,150	2,180	1,660	**	**

\*\*  $K_L/L > 200$

Column loads are for allowable axial loads and must be reduced for eccentric loading.

**PS200 – Crush Loads**

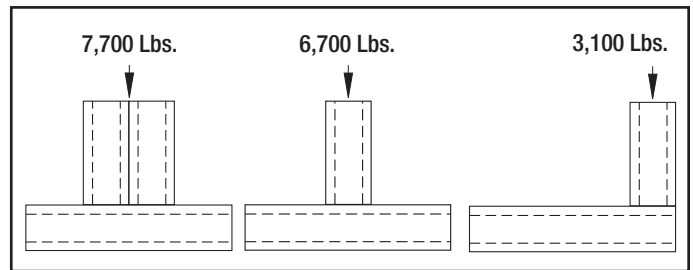

Resistance to Slip – 1,500 lbs. per bolt when 1/2" PS NS channel nuts are used.  
Pull Out Strength – 2,000 lbs. per bolt when 1/2" PS NS channel nuts are used.

**BEAM LOADING – PS 200 2T3**

Span (in)	Max Allowable Uniform Load (lb)	Defl. at Uniform Load (in)	Uniform Loading at Deflection		
			Span/180 (lbs)	Span/240 (lbs)	Span/360 (lbs)
24	3,500 *	0.02	3,500 *	3,500 *	3,500 *
36	3,190	0.07	3,190	3,190	3,190
48	2,390	0.13	2,390	2,390	2,390
60	1,910	0.20	1,910	1,910	1,620
72	1,600	0.28	1,600	1,600	1,130
84	1,370	0.39	1,370	1,240	830
96	1,200	0.51	1,200	950	630
108	1,060	0.64	1,000	750	500
120	960	0.79	810	610	410
144	800	1.14	560	420	280
168	680	1.53	410	310	210
192	600	2.02	320	240	160
216	530	2.54	250	190	130
240	480	3.16	200	150	100

\*Load limited by spot weld shear.

For concentrated load at center of span, divide uniform load by 2 and multiply corresponding deflection by 0.8. This load table is based on a solid channel section.

Loads include weight of channel, which must be deducted.

Loads must be multiplied by the applicable unbraced factor from page 42.

**COLUMN LOADING – PS 200 2T3**

Unbraced Height (in)	Max. Allowable Load at Slot Face (lbs)	Maximum Column Load Applied at C.G.			
		K = 0.65 (lbs)	K = 0.80 (lbs)	K = 1.0 (lbs)	K = 1.2 (lbs)
24	6,430	24,280	23,610	22,700	21,820
36	6,290	22,810	21,820	20,650	19,670
48	6,160	21,410	20,300	18,670	16,160
60	6,000	20,210	18,670	15,520	12,390
72	5,620	18,970	16,160	12,390	8,950
84	5,170	16,950	13,630	9,470	6,580
96	4,690	14,890	11,190	7,250	5,040
108	4,170	12,850	8,950	5,730	3,980
120	3,690	10,900	7,250	4,640	**
144	2,930	7,630	5,040	**	**

\*\*  $K_L/L > 200$

Column loads are for allowable axial loads and must be reduced for eccentric loading.

For Pierced Channels, reduce beam load values as follows:

PS 200 2T3 EH 15%

(See PS 200 2T3 EH on page28.)

# CHANNEL

**Finish:** Plain, Painted Green, Zinc dichromate, Hot-dip galvanized or Pregalvanized **Order By:** No., Length and Finish

**PS 200 2T3 EH – Channel with Elongated Holes**

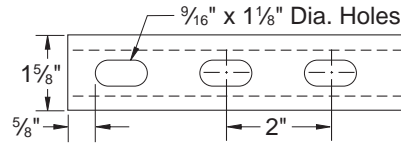
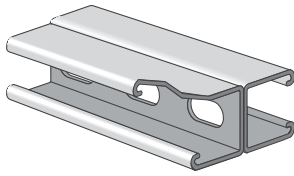

Weight: 370 lbs./100 ft.

**PS 200 2T2 – Welded Steel Channel (1 5/8" x 3 1/4" x 12 ga.)**

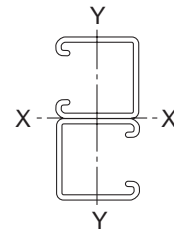
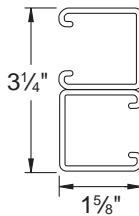
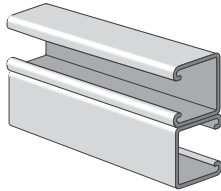

Weight: 378 lbs./100 ft.  
Allowable Moment 18,640 In-Lbs

**PS 200 2T4 – Welded Steel Channel (1 5/8" x 3 1/4" x 12 ga.)**

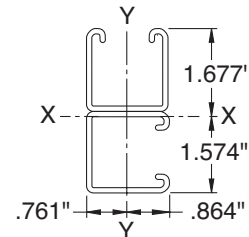
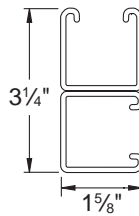
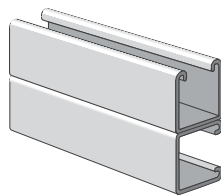

Weight: 378 lbs./100 ft.  
Allowable Moment 15,950 In-Lbs

**PS 200 2T5 – Welded Steel Channel (1 5/8" x 3 1/4" x 12 ga.)**

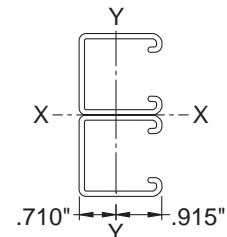
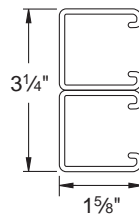
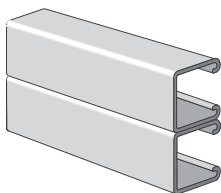

Weight: 378 lbs./100 ft.  
Allowable Moment 18,640 In-Lbs

**PS 200 3T6 – Welded Steel Channel (3 1/4" x 3 1/4" x 12 ga.)**

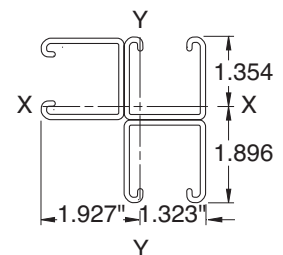
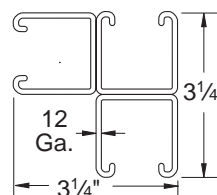
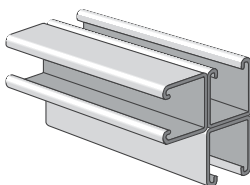

Weight: 566 lbs./100 ft.  
Allowable Moment 18,680 In-Lbs

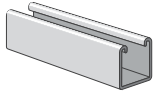

Finish: Plain, Painted Green, Zinc dichromate, Hot-dip galvanized or Pregalvanized **Order By:** No., Length and Finish

**PS 200 PLA – Welded Steel Channel & Plate**

**PS 200 PLC – Welded Steel Channel & Plate**

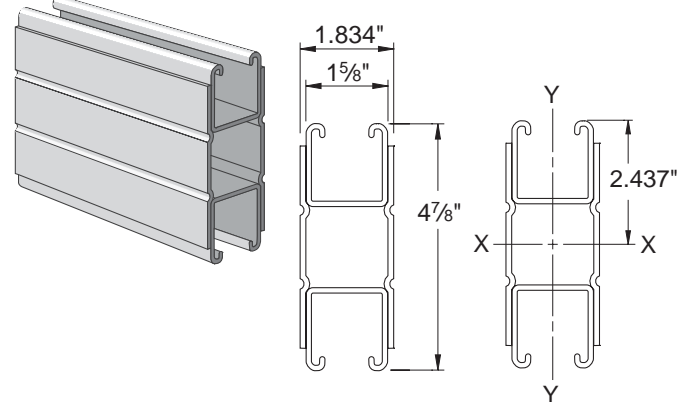
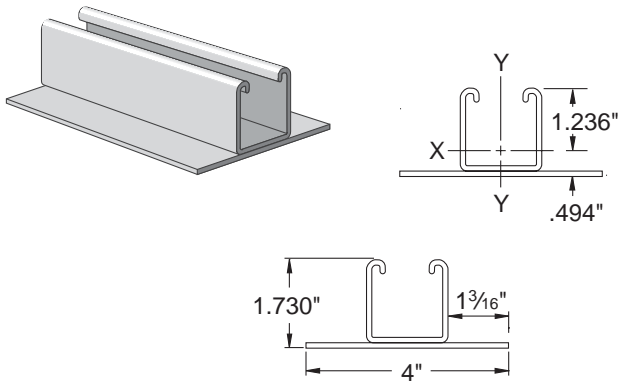

ELEMENTS OF SECTION

Part No.	Weight (lbs./100 ft.)	Area of Section (Inch <sup>2</sup> )	X-X Axis			Y-Y Axis		
			Moment of Inertia (Inch <sup>4</sup> )	Section Modulus (Inch <sup>3</sup> )	Radius of Gyration (Inch)	Moment of Inertia (Inch <sup>4</sup> )	Section Modulus (Inch <sup>3</sup> )	Radius of Gyration (Inch)
PS 200 PLA	333	0.739	0.287	0.248	0.623	0.617	0.290	0.914
PS 200 PLC	668	1.965	4.068	1.669	1.439	1.092	1.190	0.745

**PS 200 PLC – Load Data**

BEAM LOADING – PS 200 PLC

Span (in)	Max Allowable Uniform Load (lb)	Defl. at Uniform Load (in)	Uniform Loading at Deflection		
			Span/180 (lbs)	Span/240 (lbs)	Span/360 (lbs)
24	9,100 *	0.01	9,100 *	9,100 *	9,100 *
36	9,100 *	0.05	9,100 *	9,100 *	9,100 *
48	7,000	0.08	7,000	7,000	7,000
60	5,600	0.13	5,600	5,600	5,600
72	4,660	0.19	4,660	4,660	4,660
84	4,000	0.26	4,000	4,000	3,630
96	3,500	0.34	3,500	3,500	2,780
108	3,110	0.43	3,110	3,110	2,200
120	2,800	0.52	2,800	2,670	1,780
144	2,330	0.75	2,330	1,850	1,230
168	2,000	1.03	1,810	1,360	910
192	1,750	1.34	1,390	1,040	690
216	1,550	1.69	1,100	820	550
240	1,400	2.10	890	670	440

COLUMN LOADING – PS 200 PLC

Unbraced Height (in)	Max. Allowable Load at Slot Face (lbs)	Maximum Column Load Applied at C.G.			
		K = 0.65 (lbs)	K = 0.80 (lbs)	K = 1.0 (lbs)	K = 1.2 (lbs)
24	11,420	36,800	33,890	30,440	27,600
36	10,600	30,840	27,600	24,400	22,160
48	9,860	26,400	23,560	21,060	19,470
60	9,160	23,370	21,060	19,160	18,020
72	8,610	21,310	19,470	18,020	17,140
84	8,170	19,890	18,410	17,260	15,240
96	7,790	18,890	17,670	16,760	11,670
108	7,460	18,160	17,140	13,280	9,220
120	7,150	17,590	16,760	10,750	7,470
144	5,660	16,840	11,670	7,470	**
168	4,520	12,990	8,570	**	**

\*\*  $KL/r > 200$

Column loads are for allowable axial loads and must be reduced for eccentric loading.

\*Load limited by spot weld shear.

† Bearing load may govern capacity.

For concentrated load at center of span, divide uniform load by 2 and multiply corresponding deflection by 0.8. This load table is based on a solid channel section.

Loads include weight of channel, which must be deducted.

Loads must be multiplied by the applicable unbraced factor from page 42.

Metal Channel  
Fasteners  
Fittings  
Pipe & Conduit Clamps  
Electrical  
Concrete Inserts  
Solar Components  
Unipier®  
Jr. Channel  
Power-Angle  
Fiberglass  
Tech. Data

# CHANNEL

Finish: Plain, Painted Green, Zinc dichromate, Hot-dip galvanized or Pregalvanized Order By: No., Length and Finish

## PS 210 - Steel Channel (1 5/8" x 1 5/8" x 14 ga.)

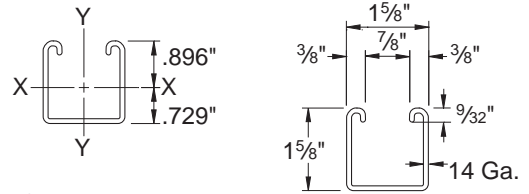
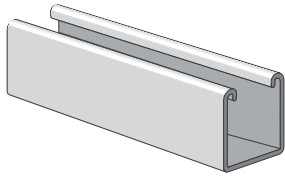

ELEMENTS OF SECTION - PS 210

Weight (lbs./100 ft.)	Area of Section (Inch <sup>2</sup> )	X-X Axis			Y-Y Axis		
		Moment of Inertia (Inch <sup>4</sup> )	Section Modulus (Inch <sup>3</sup> )	Radius of Gyration (Inch)	Moment of Inertia (Inch <sup>4</sup> )	Section Modulus (Inch <sup>3</sup> )	Radius of Gyration (Inch)
142	0.418	0.145	0.162	0.589	0.176	0.217	0.650

### PS 210 H - Channel with Holes

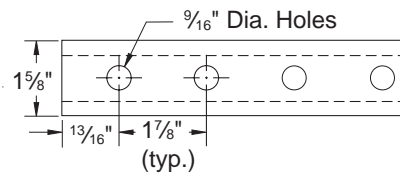
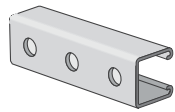

Weight: 137 lbs./100 ft.

### PS 210 EH - Channel with Elongated Holes

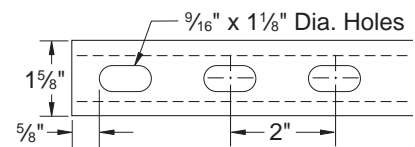
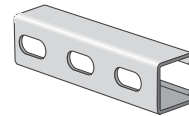

Weight: 137 lbs./100 ft.

### PS 210 S - Channel with Slots

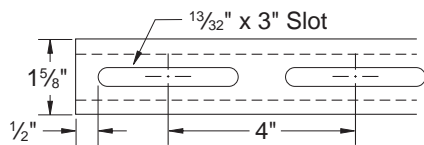
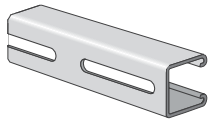

Weight: 137 lbs./100 ft.

### PS 210 K06 - Channel with Knockouts

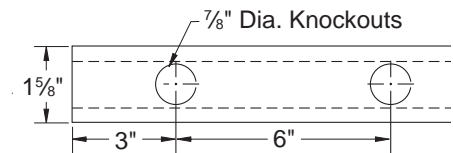
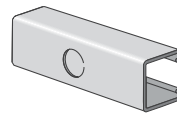

Weight: 141 lbs./100 ft.

### PS 210 2T3 - Steel Channel (1 5/8" x 3 1/4" x 14 ga.)

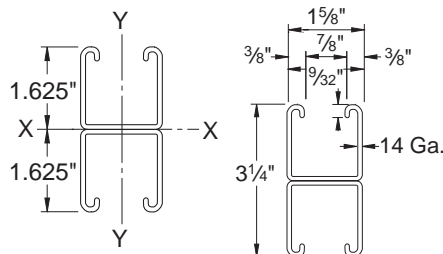
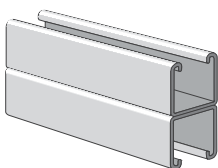

ELEMENTS OF SECTION - PS 210 2T3

Weight (lbs./100 ft.)	Area of Section (Inch <sup>2</sup> )	X-X Axis			Y-Y Axis		
		Moment of Inertia (Inch <sup>4</sup> )	Section Modulus (Inch <sup>3</sup> )	Radius of Gyration (Inch)	Moment of Inertia (Inch <sup>4</sup> )	Section Modulus (Inch <sup>3</sup> )	Radius of Gyration (Inch)
284	0.835	0.733	0.451	0.937	0.353	0.434	0.650

### PS 210 WT - Channel with Wide Slots

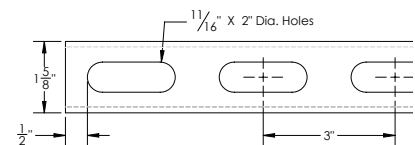
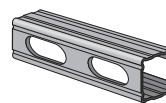

Weight: 137 lbs./100 ft.

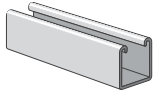

Finish: Plain, Painted Green, Zinc dichromate, Hot-dip galvanized or Pregalvanized **Order By:** No., Length and Finish

**PS 210 & PS 210 2T3 - Load Data**

**BEAM LOADING – PS 210**

Span (in)	Max Allowable Uniform Load (lb)	Defl. at Uniform Load (in)	Uniform Loading at Deflection		
			Span/180 (lbs)	Span/240 (lbs)	Span/360 (lbs)
24	1,350	0.06	1,350	1,350	1,350
36	900	0.13	900	900	700
48	680	0.23	680	590	400
60	540	0.36	510	380	250
72	450	0.51	350	260	180
84	390	0.70	260	190	130
96	340	0.92	200	150	100
108	300	1.15	160	120	80
120	270	1.42	130	90	60
144	230	2.09	90	70	40
168	190	2.75	60	50	30
192	170	3.67	50	40	NR
216	150	4.61	40	30	NR
240	140	5.90	30	NR	NR

\* Bearing load may govern capacity.

NR - Not Recommended

This load table is based on a solid channel section.

For concentrated load at center of span, divide uniform load by 2 and multiply corresponding deflection by 0.8.

Loads include weight of channel, which must be deducted.

Loads must be multiplied by the applicable unbraced factor from page 42.

For Pierced Channels, reduce beam load values as follows:

- PS-210-EH 15%      PS-210-WT 15%
- PS-210-S 15%
- PS-210-H 10%
- PS-210-K06 5%

**COLUMN LOADING – PS 210**

Unbraced Height (in)	Max. Allowable Load at Slot Face (lbs)	Maximum Column Load Applied at C.G.			
		K = 0.65 (lbs)	K = 0.80 (lbs)	K = 1.0 (lbs)	K = 1.2 (lbs)
24	2,800	8,040	7,330	6,360	5,430
36	2,410	6,480	5,430	4,190	3,210
48	1,940	4,990	3,830	2,760	2,160
60	1,550	3,740	2,760	2,050	1,640
72	1,290	2,860	2,160	1,640	1,320
84	1,100	2,310	1,780	1,370	1,110
96	950	1,950	1,520	1,180	950
108	840	1,690	1,320	1,030	**
120	760	1,490	1,180	**	**
144	630	1,210	950	**	**

\*\*  $K_L > 200$

Column loads are for allowable axial loads and must be reduced for eccentric loading.

**PS210 – Crush Loads**

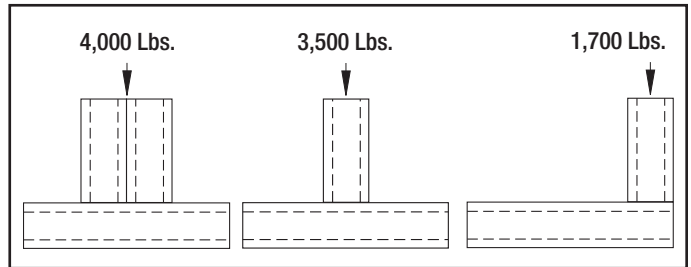

Resistance to Slip – 1,000 lbs. per bolt when 1/2" PS NS channel nuts are used.  
Pull Out Strength – 1,400 lbs. per bolt when 1/2" PS NS channel nuts are used.

**BEAM LOADING – PS 210 2T3**

Span (in)	Max Allowable Uniform Load (lb)	Defl. at Uniform Load (in)	Uniform Loading at Deflection		
			Span/180 (lbs)	Span/240 (lbs)	Span/360 (lbs)
24	2,180 *	0.02	2,180 *	2,180 *	2,180 *
36	2,180 *	0.06	2,180 *	2,180 *	2,180 *
48	1,890	0.13	1,890	1,890	1,890
60	1,510	0.20	1,510	1,510	1,280
72	1,260	0.28	1,260	1,260	890
84	1,080	0.39	1,080	980	650
96	950	0.51	950	750	500
108	840	0.64	790	590	400
120	760	0.79	640	480	320
144	630	1.13	440	330	220
168	540	1.54	330	250	160
192	470	2.00	250	190	130
216	420	2.55	200	150	100
240	380	3.16	160	120	80

\*Load limited by spot weld shear.

† Bearing load may govern capacity.

For concentrated load at center of span, divide uniform load by 2 and multiply corresponding deflection by 0.8. This load table is based on a solid channel section.

Loads include weight of channel, which must be deducted.

Loads must be multiplied by the applicable unbraced factor from page 42.

**COLUMN LOADING – PS 210 2T3**

Unbraced Height (in)	Max. Allowable Load at Slot Face (lbs)	Maximum Column Load Applied at C.G.			
		K = 0.65 (lbs)	K = 0.80 (lbs)	K = 1.0 (lbs)	K = 1.2 (lbs)
24	5,010	18,250	17,700	16,880	16,030
36	4,860	16,990	16,030	14,770	13,620
48	4,700	15,610	14,380	12,930	11,750
60	4,480	14,280	12,930	11,490	9,290
72	4,210	13,100	11,750	9,290	6,700
84	3,880	12,090	10,220	7,090	4,930
96	3,480	11,170	8,390	5,430	3,770
108	3,060	9,640	6,700	4,290	2,980
120	2,680	8,170	5,430	3,480	**
144	2,090	5,710	3,770	**	**

\*\*  $K_L > 200$

Column loads are for allowable axial loads and must be reduced for eccentric loading.

Metal Channel  
Fasteners  
Fittings  
Pipe & Conduit Clamps  
Electrical  
Concrete Inserts  
Solar Components  
Unipier®  
Jr. Channel  
Power-Angle  
Fiberglass  
Tech. Data

# CHANNEL

Finish: Plain, Painted Green, Zinc dichromate, Hot-dip galvanized or Pregalvanized Order By: No., Length and Finish

**PS 300 - Steel Channel (1 5/8" x 1 3/8" x 12 ga.)**

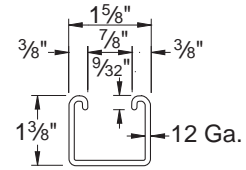
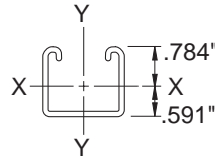
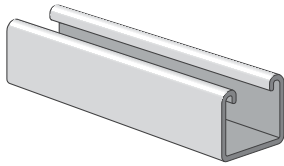

ELEMENTS OF SECTION - PS 300

Weight (lbs./100 ft.)	Area of Section (Inch <sup>2</sup> )	X-X Axis			Y-Y Axis		
		Moment of Inertia (Inch <sup>4</sup> )	Section Modulus (Inch <sup>3</sup> )	Radius of Gyration (Inch)	Moment of Inertia (Inch <sup>4</sup> )	Section Modulus (Inch <sup>3</sup> )	Radius of Gyration (Inch)
170	0.500	0.120	0.153	0.489	0.203	0.250	0.638

**PS 300 H - Channel with Holes**

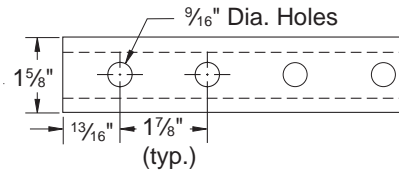
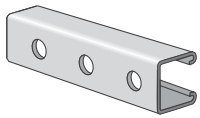

Weight: 165 lbs./100 ft.

**PS 300 EH - Channel with Elongated Holes**

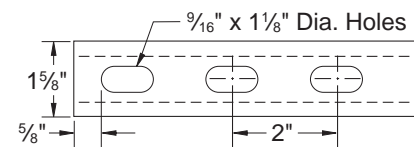
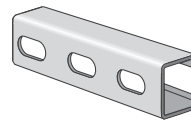

Weight: 165 lbs./100 ft.

**PS 300 S - Channel with Slots**

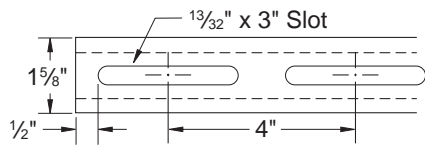
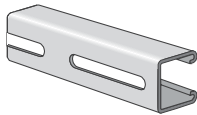

Weight: 165 lbs./100 ft.

**PS 300 2T3 EH - Channel with Elongated Holes**

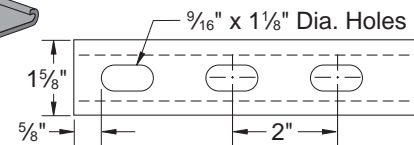
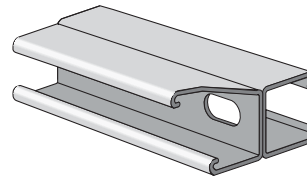

Weight: 340 lbs./100 ft.

**PS 300 2T3 - Steel Channel (1 5/8" x 2 3/4" x 12 ga.)**

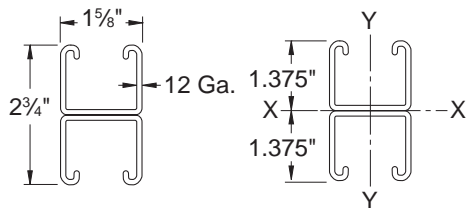
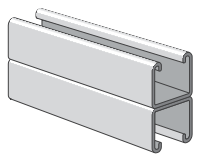

**PS 300 WT - Channel with Wide Slots**

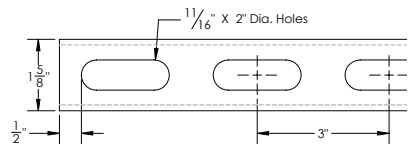
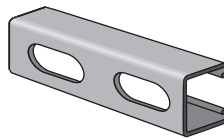

Weight: 165 lbs./100 ft.

ELEMENTS OF SECTION - PS 300 2T3

Weight (lbs./100 ft.)	Area of Section (Inch <sup>2</sup> )	X-X Axis			Y-Y Axis		
		Moment of Inertia (Inch <sup>4</sup> )	Section Modulus (Inch <sup>3</sup> )	Radius of Gyration (Inch)	Moment of Inertia (Inch <sup>4</sup> )	Section Modulus (Inch <sup>3</sup> )	Radius of Gyration (Inch)
340	1.000	0.591	0.430	0.769	0.407	0.501	0.638

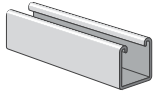

Finish: Plain, Painted Green, Zinc dichromate, Hot-dip galvanized or Pregalvanized **Order By:** No., Length and Finish

**PS 300 & PS 300 2T3 - Load Data**

**BEAM LOADING - PS 300**

Span (in)	Max Allowable Uniform Load (lb)	Defl. at Uniform Load (in)	Uniform Loading at Deflection		
			Span/180 (lbs)	Span/240 (lbs)	Span/360 (lbs)
24	1,280	0.07	1,280	1,280	1,280
36	850	0.15	850	850	580
48	640	0.26	640	490	330
60	510	0.41	420	310	210
72	430	0.59	290	220	150
84	370	0.81	210	160	110
96	320	1.05	160	120	80
108	280	1.30	130	100	60
120	260	1.66	100	80	50
144	210	2.32	70	50	40
168	180	3.15	50	40	30
192	160	4.18	40	30	NR
216	140	5.21	NR	NR	NR
240	130	6.64	NR	NR	NR

\* Bearing load may govern capacity.

NR - Not Recommended

This load table is based on a solid channel section.

For concentrated load at center of span, divide uniform load by 2 and multiply corresponding deflection by 0.8.

Loads include weight of channel, which must be deducted.

Loads must be multiplied by the applicable unbraced factor from page 42.

For Pierced Channels, reduce beam load values as follows:

- PS-300-EH 15%
- PS-300-S 15%
- PS-300-H 10%
- PS-300-WT 15%

**COLUMN LOADING - PS 300**

Unbraced Height (in)	Max. Allowable Load at Slot Face (lbs)	Maximum Column Load Applied at C.G.			
		K = 0.65 (lbs)	K = 0.80 (lbs)	K = 1.0 (lbs)	K = 1.2 (lbs)
24	3,180	9,690	8,980	8,050	7,210
36	2,920	8,160	7,210	6,130	5,240
48	2,590	6,820	5,810	4,730	3,860
60	2,300	5,740	4,730	3,690	2,990
72	2,040	4,850	3,860	2,990	2,270
84	1,830	4,100	3,240	2,400	**
96	1,650	3,530	2,770	1,840	**
108	1,450	3,080	2,270	**	**
120	1,250	2,710	1,840	**	**

\*\*  $KL/L > 200$

Column loads are for allowable axial loads and must be reduced for eccentric loading.

**PS300 - Crush Loads**

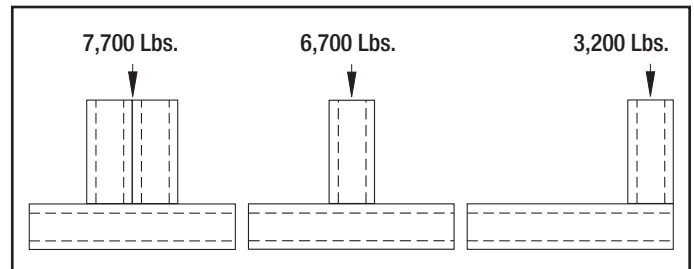

Resistance to Slip - 1,500 lbs. per bolt when 1/2" PS NS channel nuts are used.  
Pull Out Strength - 2,000 lbs. per bolt when 1/2" PS NS channel nuts are used.

**BEAM LOADING - PS 300 2T3**

Span (in)	Max Allowable Uniform Load (lb)	Defl. at Uniform Load (in)	Uniform Loading at Deflection		
			Span/180 (lbs)	Span/240 (lbs)	Span/360 (lbs)
24	2,960 *	0.03	2,960 *	2,960 *	2,960 *
36	2,400	0.08	2,400	2,400	2,400
48	1,800	0.15	1,800	1,800	1,610
60	1,440	0.23	1,440	1,440	1,030
72	1,200	0.33	1,200	1,080	720
84	1,030	0.46	1,030	790	530
96	900	0.59	810	610	400
108	800	0.75	640	480	320
120	720	0.93	520	390	260
144	600	1.34	360	270	180
168	510	1.81	260	200	130
192	450	2.38	200	150	100
216	400	3.01	160	120	80
240	360	3.72	130	100	NR

\*Load limited by spot weld shear.

† Bearing load may govern capacity.

For concentrated load at center of span, divide uniform load by 2 and multiply corresponding deflection by 0.8. This load table is based on a solid channel section.

Loads include weight of channel, which must be deducted.

Loads must be multiplied by the applicable unbraced factor from page 42.

**COLUMN LOADING - PS 300 2T3**

Unbraced Height (in)	Max. Allowable Load at Slot Face (lbs)	Maximum Column Load Applied at C.G.			
		K = 0.65 (lbs)	K = 0.80 (lbs)	K = 1.0 (lbs)	K = 1.2 (lbs)
24	5,740	21,780	21,200	20,430	19,720
36	5,620	20,520	19,720	18,830	17,680
48	5,520	19,400	18,570	16,570	14,260
60	5,330	18,510	16,570	13,670	10,810
72	5,030	16,850	14,260	10,810	7,730
84	4,630	14,990	11,930	8,180	5,680
96	4,190	13,090	9,720	6,260	4,350
108	3,720	11,230	7,730	4,950	**
120	3,300	9,460	6,260	4,010	**
144	2,620	6,590	4,350	**	**

\*\*  $KL/L > 200$

Column loads are for allowable axial loads and must be reduced for eccentric loading.

For Pierced Channels, reduce beam load values as follows:

- PS-300 2T3 EH 15%

Metal Channel  
Fasteners  
Fittings  
Pipe & Conduit Clamps  
Electrical  
Concrete Inserts  
Solar Components  
Unipier®  
Jr. Channel  
Power-Angle  
Fiberglass  
Tech. Data



# CHANNEL

**Finish:** Plain, Painted Green, Zinc dichromate, Hot-dip galvanized or Pregalvanized **Order By:** No., Length and Finish

**PS 400 - Steel Channel (1<sup>5</sup>/<sub>8</sub>" x 1" x 12 ga.)**

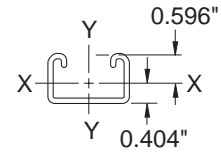
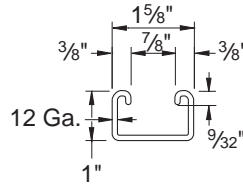
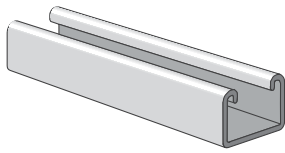

**ELEMENTS OF SECTION - PS 400**

Weight (lbs./100 ft.)	Area of Section (Inch <sup>2</sup> )	X-X Axis			Y-Y Axis		
		Moment of Inertia (Inch <sup>4</sup> )	Section Modulus (Inch <sup>3</sup> )	Radius of Gyration (Inch)	Moment of Inertia (Inch <sup>4</sup> )	Section Modulus (Inch <sup>3</sup> )	Radius of Gyration (Inch)
144	0.424	0.053	0.092	0.354	0.161	0.198	0.616

**PS 400 H - Channel with Holes**

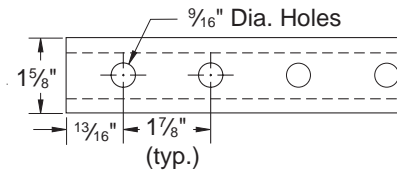
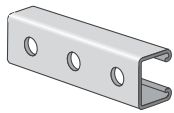

Weight: 136 lbs./100 ft.

**PS 400 EH - Channel with Elongated Holes**

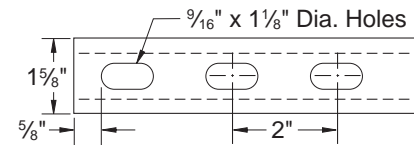
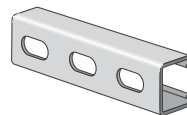

Weight: 136 lbs./100 ft.

**PS 400 S - Channel with Slots**

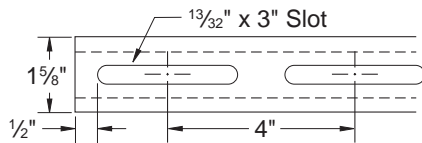
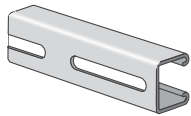

Weight: 136 lbs./100 ft.

**PS 400 WT - Channel with Wide Slots**

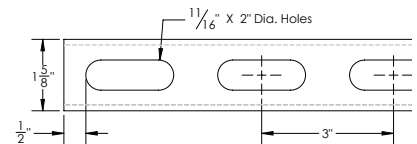
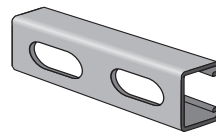

Weight: 136 lbs./100 ft.

**PS 400 2T3 - Steel Channel (1<sup>5</sup>/<sub>8</sub>" x 2" x 12 ga.)**

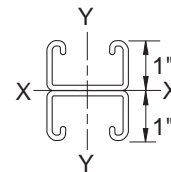
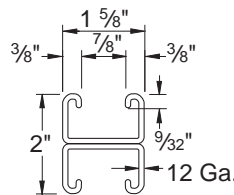
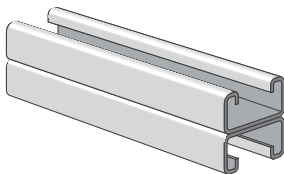

**ELEMENTS OF SECTION - PS 400 2T3**

Weight (lbs./100 ft.)	Area of Section (Inch <sup>2</sup> )	X-X Axis			Y-Y Axis		
		Moment of Inertia (Inch <sup>4</sup> )	Section Modulus (Inch <sup>3</sup> )	Radius of Gyration (Inch)	Moment of Inertia (Inch <sup>4</sup> )	Section Modulus (Inch <sup>3</sup> )	Radius of Gyration (Inch)
288	0.849	0.255	0.255	0.548	0.322	0.396	0.616

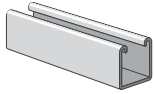

Finish: Plain, Painted Green, Zinc dichromate, Hot-dip galvanized or Pregalvanized **Order By:** No., Length and Finish

**PS 400 & PS 400 2T3 - Load Data**

**BEAM LOADING - PS 400**

Span (in)	Max Allowable Uniform Load (lb)	Defl. at Uniform Load (in)	Uniform Loading at Deflection		
			Span/180 (lbs)	Span/240 (lbs)	Span/360 (lbs)
24	770	0.09	770	770	580
36	510	0.20	510	390	260
48	380	0.35	290	220	150
60	310	0.56	190	140	90
72	260	0.80	130	100	60
84	220	1.08	90	70	50
96	190	1.39	70	50	40
108	170	1.78	60	40	30
120	150	2.15	50	30	20
144	130	3.22	30	20	20
168	110	4.32	NR	NR	NR
192	100	5.87	NR	NR	NR
216	90	7.52	NR	NR	NR

\* Bearing load may govern capacity.

NR - Not Recommended

This load table is based on a solid channel section.

For concentrated load at center of span, divide uniform load by 2 and multiply corresponding deflection by 0.8.

Loads include weight of channel, which must be deducted.

Loads must be multiplied by the applicable unbraced factor from page 42.

For Pierced Channels, reduce beam load values as follows:

- PS-400-EH 15%
- PS-400-S 15%
- PS-400-H 10%
- PS-400-WT 15%

**COLUMN LOADING - PS 400**

Unbraced Height (in)	Max. Allowable Load at Slot Face (lbs)	Maximum Column Load Applied at C.G.			
		K = 0.65 (lbs)	K = 0.80 (lbs)	K = 1.0 (lbs)	K = 1.2 (lbs)
24	2,620	8,280	7,760	7,140	6,580
36	2,470	7,210	6,580	5,310	4,030
48	2,180	6,200	4,870	3,280	2,280
60	1,770	4,760	3,280	2,100	**
72	1,420	3,450	2,280	**	**
84	1,150	2,530	1,670	**	**
96	**	1,940	**	**	**

\*\*  $KL/r > 200$

Column loads are for allowable axial loads and must be reduced for eccentric loading.

**PS400 - Crush Loads**

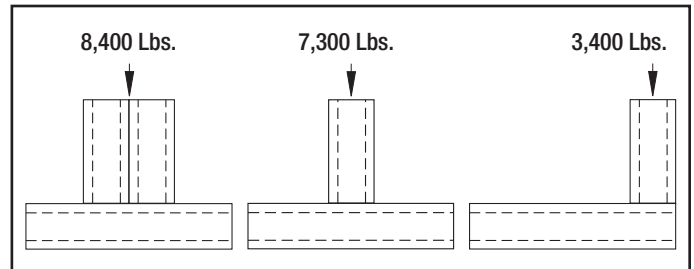

Resistance to Slip - 1,500 lbs. per bolt when 1/2" PS NS channel nuts are used.  
Pull Out Strength - 2,000 lbs. per bolt when 1/2" PS NS channel nuts are used.

**BEAM LOADING - PS 400 2T3**

Span (in)	Max Allowable Uniform Load (lb)	Defl. at Uniform Load (in)	Uniform Loading at Deflection		
			Span/180 (lbs)	Span/240 (lbs)	Span/360 (lbs)
24	2,140 *	0.05	2,140 *	2,140 *	2,140 *
36	1,420	0.11	1,420	1,420	1,240
48	1,070	0.20	1,070	1,040	700
60	850	0.32	850	670	450
72	710	0.46	620	460	310
84	610	0.63	450	340	230
96	530	0.81	350	260	170
108	470	1.03	280	210	140
120	430	1.29	220	170	110
144	360	1.86	150	120	80
168	310	2.54	110	90	60
192	270	3.31	90	70	NR
216	240	4.19	70	NR	NR
240	210	5.03	60	NR	NR

\*Load limited by spot weld shear.

† Bearing load may govern capacity.

For concentrated load at center of span, divide uniform load by 2 and multiply corresponding deflection by 0.8. This load table is based on a solid channel section.

Loads include weight of channel, which must be deducted.

Loads must be multiplied by the applicable unbraced factor from page 42.

**COLUMN LOADING - PS 400 2T3**

Unbraced Height (in)	Max. Allowable Load at Slot Face (lbs)	Maximum Column Load Applied at C.G.			
		K = 0.65 (lbs)	K = 0.80 (lbs)	K = 1.0 (lbs)	K = 1.2 (lbs)
24	4,720	18,310	17,840	17,300	16,760
36	4,640	17,360	16,760	15,260	13,610
48	4,470	16,280	14,720	12,460	10,170
60	4,230	14,590	12,460	9,610	6,980
72	3,930	12,750	10,170	6,980	4,840
84	3,520	10,880	7,990	5,130	3,560
96	3,070	9,050	6,130	3,920	**
108	2,690	7,340	4,840	3,100	**
120	2,360	5,940	3,920	**	**

\*\*  $KL/r > 200$

Column loads are for allowable axial loads and must be reduced for eccentric loading.

# CHANNEL

**Finish:** Plain, Painted Green, Zinc dichromate, Hot-dip galvanized or Pregalvanized **Order By:** No., Length and Finish

**PS 500 – Steel Channel (1<sup>5</sup>/<sub>8</sub>" x 1<sup>3</sup>/<sub>16</sub>" x 14 ga.)**

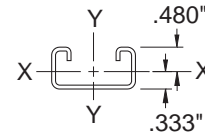
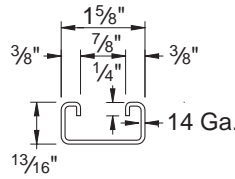
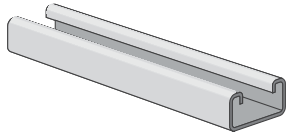

ELEMENTS OF SECTION – PS 500

Weight (lbs./100 ft.)	Area of Section (Inch <sup>2</sup> )	X-X Axis			Y-Y Axis		
		Moment of Inertia (Inch <sup>4</sup> )	Section Modulus (Inch <sup>3</sup> )	Radius of Gyration (Inch)	Moment of Inertia (Inch <sup>4</sup> )	Section Modulus (Inch <sup>3</sup> )	Radius of Gyration (Inch)
98	0.290	0.026	0.054	0.298	0.107	0.132	0.609

**PS 500 H – Channel with Holes**

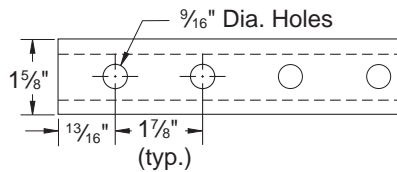
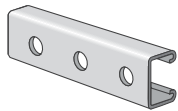

Weight: 87 lbs./100 ft.

**PS 500 EH – Channel with Elongated Holes**

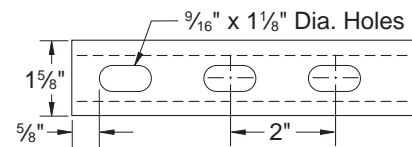
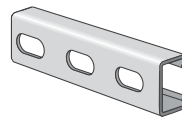

Weight: 87 lbs./100 ft.

**PS 500 S – Channel with Slots**

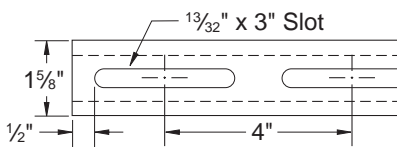
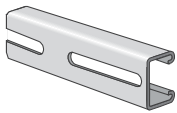

Weight: 87 lbs./100 ft.

**PS 500 2T3 EH – Channel with Elongated Holes**

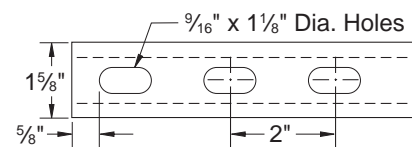
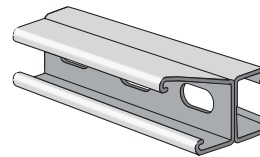

Weight: 174 lbs./100 ft.

**PS 500 2T3 – Steel Channel (1<sup>5</sup>/<sub>8</sub>" x 1<sup>5</sup>/<sub>8</sub>" x 14 ga.)**

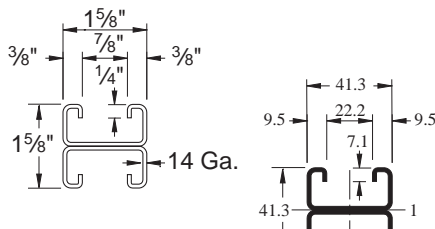
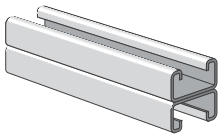

**PS 500 WT – Channel with Wide Slots**

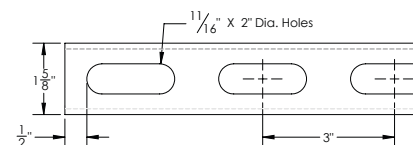
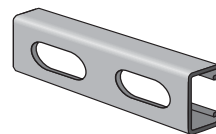

Weight: 87 lbs./100 ft.

ELEMENTS OF SECTION – PS 500 2T3

Weight (lbs./100 ft.)	Area of Section (Inch <sup>2</sup> )	X-X Axis			Y-Y Axis		
		Moment of Inertia (Inch <sup>4</sup> )	Section Modulus (Inch <sup>3</sup> )	Radius of Gyration (Inch)	Moment of Inertia (Inch <sup>4</sup> )	Section Modulus (Inch <sup>3</sup> )	Radius of Gyration (Inch)
197	0.579	0.117	0.143	0.449	0.214	0.264	0.608

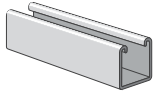

Finish: Plain, Painted Green, Zinc dichromate, Hot-dip galvanized or Pregalvanized **Order By:** No., Length and Finish

**PS 500 & PS 500 2T3 - Load Data**

**BEAM LOADING – PS 500**

Span (in)	Max Allowable Uniform Load (lb)	Defl. at Uniform Load (in)	Uniform Loading at Deflection		
			Span/180 (lbs)	Span/240 (lbs)	Span/360 (lbs)
24	450	0.11	450	420	280
36	300	0.24	250	190	130
48	230	0.44	140	110	70
60	180	0.67	90	70	50
72	150	0.96	60	50	30
84	130	1.32	50	30	20
96	110	1.67	40	30	20
108	100	2.16	30	20	10
120	90	2.67	20	20	10

\* Bearing load may govern capacity.

This load table is based on a solid channel section.

For concentrated load at center of span, divide uniform load by 2 and multiply corresponding deflection by 0.8.

Loads include weight of channel, which must be deducted.

Loads must be multiplied by the applicable unbraced factor from page 42.

For Pierced Channels, reduce beam load values as follows:

- PS-500-EH 15%
- PS-500-S 15%
- PS-500-H 10%
- PS-500-WT 15%

**COLUMN LOADING – PS 500**

Unbraced Height (in)	Max. Allowable Load at Slot Face (lbs)	Maximum Column Load Applied at C.G.			
		K = 0.65 (lbs)	K = 0.80 (lbs)	K = 1.0 (lbs)	K = 1.2 (lbs)
24	1,840	5,610	5,210	4,570	3,850
36	1,640	4,660	3,850	2,800	1,960
48	1,310	3,490	2,480	1,590	1,100
60	1,000	2,400	1,590	**	**
72	770	1,670	1,100	**	**

\*\*  $K_L / l > 200$

Column loads are for allowable axial loads and must be reduced for eccentric loading.

**PS500 – Crush Loads**

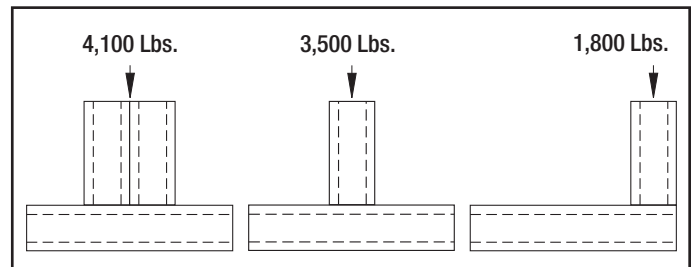

Resistance to Slip – 1,000 lbs. per bolt when 1/2" PS NS channel nuts are used.

Pull Out Strength – 1,400 lbs. per bolt when 1/2" PS NS channel nuts are used.

**BEAM LOADING – PS 500 2T3**

Span (in)	Max Allowable Uniform Load (lb)	Defl. at Uniform Load (in)	Uniform Loading at Deflection		
			Span/180 (lbs)	Span/240 (lbs)	Span/360 (lbs)
24	1,090 *	0.06	1,090 *	1,090 *	1,090 *
36	800	0.14	800	800	570
48	600	0.25	600	480	320
60	480	0.39	410	310	200
72	400	0.57	280	210	140
84	340	0.76	210	160	100
96	300	1.00	160	120	80
108	270	1.29	130	90	60
120	240	1.57	100	80	50

\*Load limited by spot weld shear.

† Bearing load may govern capacity.

For concentrated load at center of span, divide uniform load by 2 and multiply corresponding deflection by 0.8. This load table is based on a solid channel section.

Loads include weight of channel, which must be deducted.

Loads must be multiplied by the applicable unbraced factor from page 42.

**COLUMN LOADING – PS 500 2T3**

Unbraced Height	Max Allowable Load at Slot Face	Max. Column Load Applied at C.G.			
		K = 0.65	K = 0.80	K = 1.0	K = 1.2
24	3,240	12,370	11,950	11,370	10,540
36	3,120	11,470	10,540	9,160	7,720
48	2,940	10,090	8,680	6,770	4,980
60	2,680	8,560	6,770	4,590	3,190
72	2,310	7,010	4,980	3,190	2,220
84	1,950	5,530	3,660	2,340	**
96	1,650	4,250	2,800	**	**
108	1,410	3,360	2,220	**	**

\*\*  $K_L / l > 200$

Column loads are for allowable axial loads and must be reduced for eccentric loading.

For Pierced Channels, reduce beam load values as follows:

- PS-500 2T3 EH 15%

Metal Channel  
Fasteners  
Fittings  
Pipe & Conduit Clamps  
Electrical  
Concrete Inserts  
Solar Components  
Unipier®  
Jr. Channel  
Power-Angle  
Fiberglass  
Tech. Data

# CHANNEL

Finish: Plain, Painted Green, Zinc dichromate, Hot-dip galvanized or Pregalvanized Order By: No., Length and Finish

## PS 520 - Steel Channel (1<sup>5</sup>/<sub>8</sub>" x 1<sup>3</sup>/<sub>16</sub>" x 12 ga.)

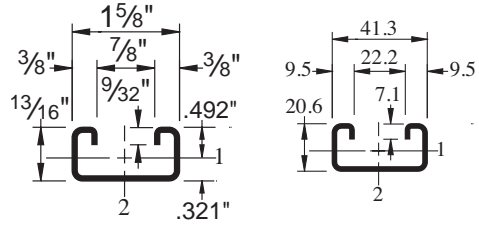
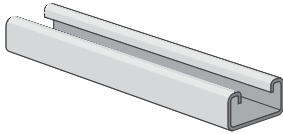

ELEMENTS OF SECTION – PS 520

Weight (lbs./100 ft.)	Area of Section (Inch <sup>2</sup> )	X-X Axis			Y-Y Axis		
		Moment of Inertia (Inch <sup>4</sup> )	Section Modulus (Inch <sup>3</sup> )	Radius of Gyration (Inch)	Moment of Inertia (Inch <sup>4</sup> )	Section Modulus (Inch <sup>3</sup> )	Radius of Gyration (Inch)
131	0.384	0.031	0.064	0.283	0.138	0.170	0.599

## PS 520 H - Channel with Holes

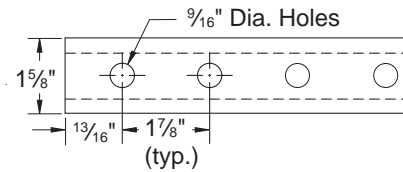
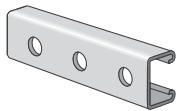

Weight: 120 lbs./100 ft.

## PS 520 EH - Channel with Elongated Holes

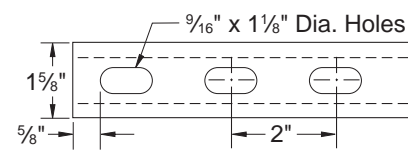
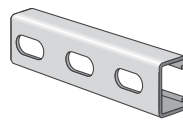

Weight: 120 lbs./100 ft.

## PS 520 S - Channel with Slots

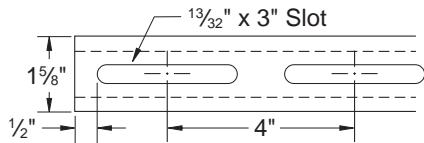
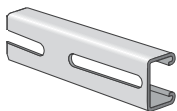

Weight: 118 lbs./100 ft.

## PS 520 WT - Channel with Wide Slots

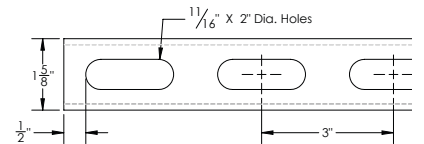
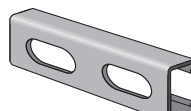

Weight: 120 lbs./100 ft.

## PS 520 2T3 - Steel Channel (1<sup>5</sup>/<sub>8</sub>" x 1<sup>5</sup>/<sub>8</sub>" x 12 ga.)

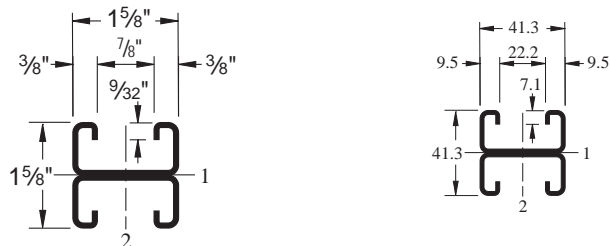
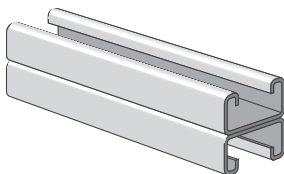

ELEMENTS OF SECTION – PS 520 2T3

Weight (lbs./100 ft.)	Area of Section (Inch <sup>2</sup> )	X-X Axis			Y-Y Axis		
		Moment of Inertia (Inch <sup>4</sup> )	Section Modulus (Inch <sup>3</sup> )	Radius of Gyration (Inch)	Moment of Inertia (Inch <sup>4</sup> )	Section Modulus (Inch <sup>3</sup> )	Radius of Gyration (Inch)
262	0.770	0.146	0.180	0.436	0.277	0.340	0.599

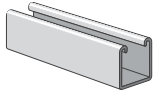

Finish: Plain, Painted Green, Zinc dichromate, Hot-dip galvanized or Pregalvanized **Order By:** No., Length and Finish

**PS 520 – Steel Channel (1<sup>5</sup>/<sub>8</sub>" x 1<sup>3</sup>/<sub>16</sub>" x 12 ga.) - Load Data**

**BEAM LOADING – PS 520**

Span (in)	Max Allowable Uniform Load (lb)	Defl. at Uniform Load (in)	Uniform Loading at Deflection		
			Span/180 (lbs)	Span/240 (lbs)	Span/360 (lbs)
24	540	0.11	540	510	340
36	360	0.24	300	220	150
48	270	0.43	170	130	80
60	220	0.68	110	80	50
72	180	0.96	70	60	40
84	150	1.27	60	40	30
96	130	1.65	40	30	20
108	120	2.16	30	20	20
120	110	2.72	30	20	NR
144	90	3.84	20	NR	NR
168	80	5.43	NR	NR	NR
192	70	7.09	NR	NR	NR

This load table is based on a solid channel section.  
 For concentrated load at center of span, divide uniform load by 2 and multiply corresponding deflection by 0.8.  
 Loads include weight of channel, which must be deducted.  
 Loads must be multiplied by the applicable unbraced factor from page 42.  
 For Pierced Channels, reduce beam load values as follows:

- PS-520-EH 15%
- PS-520-H 10%
- PS-520-S 15%
- PS-520-WT 15%

**COLUMN LOADING – PS 520**

Unbraced Height (in)	Max. Allowable Load at Slot Face (lbs)	Maximum Column Load Applied at C.G.			
		K = 0.65 (lbs)	K = 0.80 (lbs)	K = 1.0 (lbs)	K = 1.2 (lbs)
24	2,250	7,480	6,800	5,820	4,810
36	1,980	5,950	4,810	3,380	2,350
48	1,580	4,310	2,970	1,900	**
60	1,210	2,880	1,900	**	**
72	**	2,000	**	**	**

\*\*  $K_L > 200$   
 Column loads are for allowable axial loads and must be reduced for eccentric loading.

**PS520 – Crush Loads**

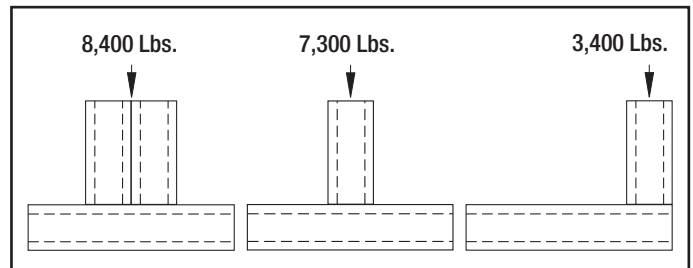

Resistance to Slip – 1,500 lbs. per bolt when 1/2" PS NS channel nuts are used.  
 Pull Out Strength – 1,500 lbs. per bolt when 1/2" PS NS channel nuts are used.

**BEAM LOADING – PS 520 2T3**

Span (in)	Max Allowable Uniform Load (lb)	Defl. at Uniform Load (in)	Uniform Loading at Deflection		
			Span/180 (lbs)	Span/240 (lbs)	Span/360 (lbs)
24	1,510	0.06	1,510	1,510	1,510
36	1,010	0.14	1,010	1,010	710
48	760	0.25	760	600	400
60	610	0.40	510	380	260
72	500	0.56	360	270	180
84	430	0.77	260	200	130
96	380	1.01	200	150	100
108	340	1.29	160	120	80
120	300	1.56	130	100	60
144	250	2.25	90	70	40
168	220	3.14	70	50	NR
192	190	4.05	50	NR	NR
216	170	5.16	NR	NR	NR
240	150	6.24	NR	NR	NR

This load table is based on a solid channel section.  
 For concentrated load at center of span, divide uniform load by 2 and multiply corresponding deflection by 0.8.  
 Loads include weight of channel, which must be deducted.  
 Loads must be multiplied by the applicable unbraced factor from page 42.  
 For Pierced Channels, reduce beam load values as follows:

**COLUMN LOADING – PS 520 2T3**

Unbraced Height (in)	Max. Allowable Load at Slot Face (lbs)	Maximum Column Load Applied at C.G.			
		K = 0.65 (lbs)	K = 0.80 (lbs)	K = 1.0 (lbs)	K = 1.2 (lbs)
24	4,140	16,490	15,980	14,970	13,810
36	3,980	15,100	13,810	11,910	9,940
48	3,730	13,190	11,260	8,650	6,270
60	3,390	11,090	8,650	5,780	4,010
72	2,950	8,970	6,270	4,010	2,790
84	2,510	6,980	4,610	2,950	**
96	2,130	5,340	3,530	**	**
108	1,820	4,220	2,790	**	**
120	**	3,420	**	**	**

\*\*  $K_L > 200$   
 Column loads are for allowable axial loads and must be reduced for eccentric loading.

Metal Channel  
Fasteners  
Fittings  
Pipe & Conduit Clamps  
Electrical  
Concrete Inserts  
Solar Components  
Unipier®  
Jr. Channel  
Power-Angle  
Fiberglass  
Tech. Data

# CHANNEL

Finish: Plain, Painted Green, Zinc dichromate, Hot-dip galvanized or Pregalvanized Order By: No., Length and Finish

## PS 560 - Steel Channel (1<sup>5</sup>/<sub>8</sub>" x 1<sup>3</sup>/<sub>16</sub>" x 16 ga.)

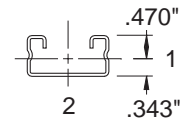
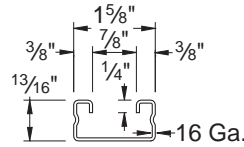
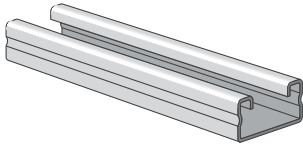

### ELEMENTS OF SECTION - PS 560

Weight (lbs./100 ft.)	Area of Section (Inch <sup>2</sup> )	X-X Axis			Y-Y Axis		
		Moment of Inertia (Inch <sup>4</sup> )	Section Modulus (Inch <sup>3</sup> )	Radius of Gyration (Inch)	Moment of Inertia (Inch <sup>4</sup> )	Section Modulus (Inch <sup>3</sup> )	Radius of Gyration (Inch)
83	0.244	0.023	0.049	0.306	0.092	0.113	0.613

## PS 560 S - Channel with Slots

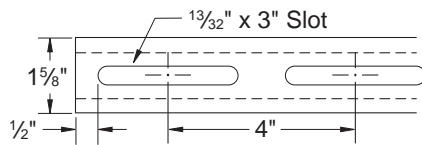
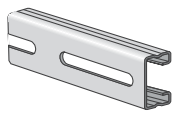

Weight: 79 lbs./100 ft.

## PS 560 EH - Channel with Elongated Holes

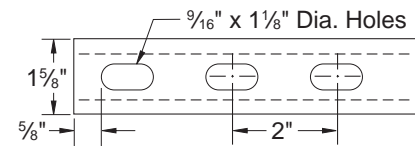
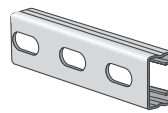

Weight: 79 lbs./100 ft.

## PS 560 WT - Channel with Wide Slots

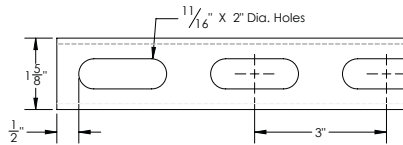
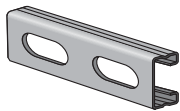

Weight: 79 lbs./100 ft.

## PS 560 2T3 - Steel Channel (1<sup>5</sup>/<sub>8</sub>" x 1<sup>5</sup>/<sub>8</sub>" x 16 ga.)

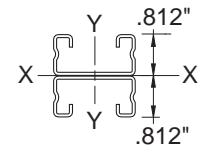
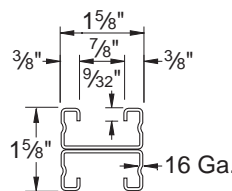
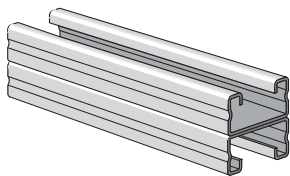

### ELEMENTS OF SECTION - PS 560 2T3

Weight (lbs./100 ft.)	Area of Section (Inch <sup>2</sup> )	X-X Axis			Y-Y Axis		
		Moment of Inertia (Inch <sup>4</sup> )	Section Modulus (Inch <sup>3</sup> )	Radius of Gyration (Inch)	Moment of Inertia (Inch <sup>4</sup> )	Section Modulus (Inch <sup>3</sup> )	Radius of Gyration (Inch)
166	0.478	0.104	0.128	0.462	0.183	0.225	0.613

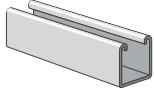

Finish: Plain, Painted Green, Zinc dichromate, Hot-dip galvanized or Pregalvanized **Order By:** No., Length and Finish

**PS 560 – Steel Channel (1<sup>5</sup>/<sub>8</sub>" x 1<sup>3</sup>/<sub>16</sub>" x 16 ga.) - Load Data**

**BEAM LOADING – PS 560**

Span (in)	Max Allowable Uniform Load (lb)	Defl. at Uniform Load (in)	Uniform Loading at Deflection		
			Span/180 (lbs)	Span/240 (lbs)	Span/360 (lbs)
24	410	0.11	410	370	250
36	270	0.24	220	170	110
48	200	0.43	120	90	60
60	160	0.67	80	60	40
72	140	1.01	60	40	30
84	120	1.38	40	30	20
96	100	1.72	30	20	20
108	90	2.20	20	20	10
120	80	2.68	20	10	10

\* Bearing load may govern capacity.

This load table is based on a solid channel section.

For concentrated load at center of span, divide uniform load by 2 and multiply corresponding deflection by 0.8.

Loads include weight of channel, which must be deducted.

Loads must be multiplied by the applicable unbraced factor from page 42.

For Pierced Channels, reduce beam load values as follows:

- PS-560-EH 15%
- PS-560-S 15%
- PS-560-WT 15%

**COLUMN LOADING – PS 560**

Unbraced Height (in)	Max. Allowable Load at Slot Face (lbs)	Maximum Column Load Applied at C.G.			
		K = 0.65 (lbs)	K = 0.80 (lbs)	K = 1.0 (lbs)	K = 1.2 (lbs)
24	1,630	4,670	4,290	3,780	3,310
36	1,450	3,840	3,310	2,460	1,730
48	1,160	3,030	2,190	1,400	970
60	870	2,120	1,400	900	**
72	670	1,470	970	**	**

\*\*  $KL_r > 200$

Column loads are for allowable axial loads and must be reduced for eccentric loading.

**PS560 – Crush Loads**

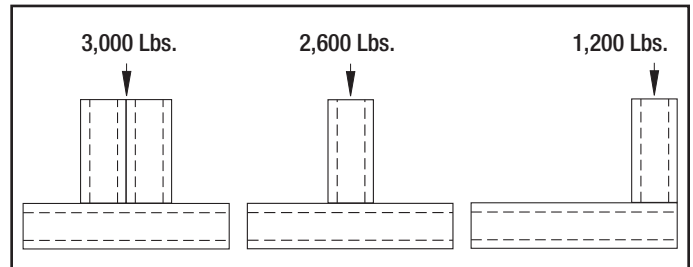

Resistance to Slip – 1,000 lbs. per bolt when 1/2" PS NS channel nuts are used.

Pull Out Strength – 1,000 lbs. per bolt when 1/2" PS NS channel nuts are used.

**BEAM LOADING – PS 560 2T3**

Span (in)	Max Allowable Uniform Load (lb)	Defl. at Uniform Load (in)	Uniform Loading at Deflection		
			Span/180 (lbs)	Span/240 (lbs)	Span/360 (lbs)
24	810 *	0.05	810 *	810 *	810 *
36	710	0.14	710	710	500
48	540	0.25	540	430	280
60	430	0.40	360	270	180
72	360	0.57	250	190	130
84	310	0.78	190	140	90
96	270	1.02	140	110	70
108	240	1.29	110	80	60
120	210	1.54	90	70	50
144	180	2.29	60	50	30

\*Load limited by spot weld shear.

† Bearing load may govern capacity.

For concentrated load at center of span, divide uniform load by 2 and multiply corresponding deflection by 0.8. This load table is based on a solid channel section.

Loads include weight of channel, which must be deducted.

Loads must be multiplied by the applicable unbraced factor from page 42.

**COLUMN LOADING – PS 560 2T3**

Unbraced Height (in)	Max. Allowable Load at Slot Face (lbs)	Maximum Column Load Applied at C.G.			
		K = 0.65 (lbs)	K = 0.80 (lbs)	K = 1.0 (lbs)	K = 1.2 (lbs)
24	2,830	10,390	10,000	9,470	8,960
36	2,740	9,530	8,960	7,870	6,700
48	2,590	8,620	7,480	5,910	4,440
60	2,340	7,380	5,910	4,090	2,840
72	2,020	6,110	4,440	2,840	1,970
84	1,700	4,880	3,260	2,090	**
96	1,440	3,780	2,500	**	**
108	1,230	2,990	1,970	**	**

\*\*  $KL_r > 200$

Column loads are for allowable axial loads and must be reduced for eccentric loading.



## PS 6153 - Strut Safety End Cap

(For OSHA Req'd End of Hand Rail)

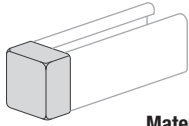

Material: Red Colored PVC

Part No.	Use With	Wt./100 pcs.
PS-6153-1	PS-100, PS200 2T3	5.0
PS-6153-2	PS-200, PS-210	2.8
PS-6153-3	PS-300	2.5
PS-6153-5	PS-500, PS-520, PS560	2.0

## PS 6152 - Decorative End Cap

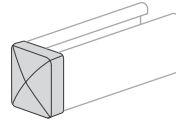

Finish: Electro-galvanized  
Use With: PS-200, PS-210

Weight: 10 lbs./100 pcs.

## PS 9050 - Green Touch-up Spray Paint



Aerosol can may be subject to shipping restrictions

Weight: 253 lbs./100

## Lateral Bracing Load Reduction Charts

Lateral Bracing Factors										
Span		Single Channel								
Ft.	In	PS 100	PS 150	PS 200	PS 210	PS 300	PS 400	PS 500	PS 520	PS 560
2	24	0.98	0.99	1.00	1.00	1.00	1.00	1.00	1.00	1.00
3	36	0.85	0.89	0.94	0.89	0.96	1.00	0.98	1.00	0.94
4	48	0.70	0.77	0.88	0.78	0.91	0.98	0.94	1.00	0.88
5	60	0.55	0.67	0.82	0.68	0.88	0.96	0.91	1.00	0.83
6	72	0.44	0.58	0.78	0.59	0.84	0.94	0.89	0.98	0.79
7	84	0.38	0.51	0.75	0.52	0.82	0.92	0.86	0.97	0.75
8	96	0.33	0.46	0.71	0.47	0.79	0.91	0.84	0.96	0.72
9	108	0.30	0.42	0.69	0.43	0.77	0.89	0.82	0.95	0.69
10	120	0.28	0.40	0.66	0.40	0.75	0.87	0.80	0.93	0.66
12	144	0.24	0.36	0.61	0.36	0.70	0.84	0.76	0.91	0.60
14	168	0.22	0.32	0.55	0.32	0.66	0.81	0.73	0.89	0.55
16	192	0.21	0.30	0.51	0.30	0.62	0.78	0.69	0.86	0.50
18	216	0.19	0.28	0.47	0.28	0.58	0.75	0.65	0.84	0.47
20	240	0.18	0.26	0.44	0.26	0.54	0.72	0.61	0.81	0.43

Lateral Bracing Factors										
Span		Double Channel								
Ft.	In	PS 100 2T3	PS 150 2T3	PS 200 2T3	PS 210 2T3	PS 300 2T3	PS 400 2T3	PS 500 2T3	PS 520 2T3	PS 560 2T3
2	24	1.00	1.00	1.00	1.00	1.00	1.00	1.00	1.00	1.00
3	36	1.00	1.00	1.00	1.00	1.00	1.00	1.00	1.00	1.00
4	48	0.97	0.98	1.00	0.98	1.00	1.00	1.00	1.00	0.98
5	60	0.90	0.93	0.97	0.93	0.98	1.00	0.96	1.00	0.93
6	72	0.83	0.87	0.93	0.87	0.95	0.97	0.92	0.97	0.88
7	84	0.76	0.81	0.89	0.82	0.92	0.95	0.89	0.95	0.83
8	96	0.68	0.76	0.85	0.76	0.88	0.92	0.85	0.92	0.79
9	108	0.61	0.70	0.81	0.70	0.85	0.90	0.81	0.90	0.74
10	120	0.54	0.64	0.78	0.65	0.82	0.87	0.78	0.87	0.69
12	144	0.43	0.53	0.70	0.54	0.76	0.82	0.71	0.83	0.60
14	168	0.35	0.45	0.63	0.45	0.70	0.77	0.64	0.78	0.51
16	192	0.30	0.39	0.56	0.39	0.64	0.72	0.57	0.73	0.44
18	216	0.27	0.34	0.49	0.34	0.58	0.67	0.50	0.68	0.39
20	240	0.24	0.30	0.44	0.31	0.52	0.62	0.45	0.63	0.35

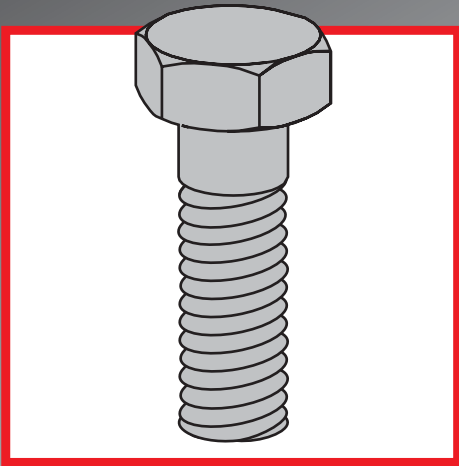

# FASTENERS

*Power-Strut Clamping Nuts are cold formed, with two grooves, each with six sharp teeth and then case hardened. These sharp hardened teeth bite into the inturned edges of the Power-Strut channel forming a strong vise-like connection giving greater strength and resistance to slippage.*

## MATERIAL:

Power-Strut channel nuts meet the standards as shown in the table below, and are case hardened. Hex head bolts conform to SAE J429 GR 2 (exceeds ASTM A307). Stainless Steel is available upon request.

Bolt Size	Channel Nut ASTM
1/4" & 5/16"	A1011 SS GR33
3/8", 7/16" & 1/2"	A576 GR1015 Modified
5/8" & 3/4"	A36 or A675 GR60
7/8"	A36

## SCREW THREADS DATA:

All Power-Strut nuts and bolts are manufactured to meet the Unified Screw Threads standard, ANSI B1.1, Coarse Series UNC, class 2.

## STANDARD FINISH:

All fasteners have an electro-galvanized finish. Channel Nuts also available in hot-dip galvanized.

## RECOMMENDED BOLT TORQUE:

Bolt Size	1/4"-20	5/16"-18	3/8"-16	1/2"-13	5/8"-11	3/4"-10
Rec. Torque Ft-Lbs	6	11	19	50	100	125
Max. Torque Ft-Lbs	7	15	25	70	125	135

## Channel Nut Selection Chart

Nuts Channel											
	PS LS	PS SS	PS RS	PS NS	PS NS S	PS 517	PS TG	PS 3281	PS 3500	PS ML	PS KW
 PS 100 1 5/8 x 3/4 x 12 ga.	✓			✓			✓	✓		✓	✓
 PS 150 1 5/8 x 2 1/16 x 12 ga.	✓			✓			✓	✓		✓	✓
 PS 200 1 5/8 x 1 1/8 x 12 ga.			✓	✓		✓	✓	✓	✓	✓	✓
 PS 210 1 5/8 x 1 1/8 x 14 ga.			✓	✓		✓	✓	✓	✓	✓	✓
 PS 300 1 5/8 x 1 3/8 x 12 ga.			✓	✓		✓	✓	✓	✓	✓	✓
 PS 400 1 5/8 x 1 x 12 ga.		✓		✓	✓		✓	✓		✓	✓
 PS 500 1 5/8 x 1 3/16 x 14 ga.		✓		✓*	✓		✓	✓		✓	✓
 PS 520 1 5/8 x 1 3/16 x 12 ga.		✓		✓*	✓		✓	✓		✓	✓
 PS 560 1 5/8 x 1 3/16 x 16 ga.		✓		✓*	✓		✓	✓		✓	✓

✓ Indicates Nuts To Be Used With The Channel

\* 3/8" or smaller

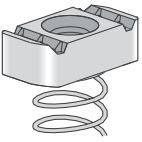

Finish: Electro-galvanized Order By: No., Size and Finish

Metal Channel  
Fasteners  
Fittings  
Pipe & Conduit Clamps  
Electrical  
Concrete Inserts  
Solar Components  
Unipier®  
Jr. Channel  
Power-Angle  
Fiberglass  
Tech. Data

**PS 6024 – Hex Head Cap Screw**

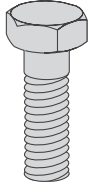

Size	Wt./100 pcs
1/4 x 3/4"	1.5
1/4 x 1"	1.8
1/4 x 1 1/4"	2.1
1/4 x 1 1/2"	2.4
3/8 x 3/4"	3.6
3/8 x 1"	4.2
3/8 x 1 1/4"	4.9
3/8 x 1 1/2"	5.6
3/8 x 2"	7.2
1/2 x 3/4"	8.1
1/2 x 1"	9.2
1/2 x 1 1/4"	10.4
1/2 x 1 1/2"	11.6
1/2 x 1 3/4"	13.0
1/2 x 2"	14.4

**PS 6075 – Slotted Hex Head Machine Screw**

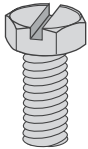

Size	Wt./100 pcs
1/4 x 3/4"	1.7
5/16 x 1"	2.6
5/16 x 1 1/4"	3.0
5/16 x 1 1/2"	3.4
3/8 x 1 1/4"	5.3

**PS 6072 – Round Head Machine Screw**

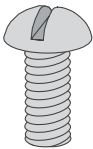

Size	Wt./100 pcs
1/4 x 3/4"	1.3
1/4 x 1"	1.6
1/4 x 1 1/4"	1.9
3/8 x 1"	4.4
3/8 x 1 1/4"	5.0
3/8 x 1 1/2"	5.6

**PS 6064 – Square Head Cone Point Set Screw**

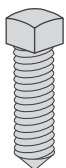

Size	Wt./100 pcs
3/8 x 1 1/2"	4.5
3/8 x 2"	6.1
1/2 x 1 1/2"	8.5
1/2 x 2"	11.4

**PS 83 – Hexagon Nut**



Size	Wt./100 pcs
1/4"	0.7
3/8"	1.6
1/2"	3.8
5/8"	7.3
3/4"	11.9

**PS 6108 – Square Nut**



Size	Wt./100 pcs
1/4"	.9
5/16"	1.6
3/8"	2.6
1/2"	5.8

**PS 209 – Flat Washer**



Size Pcs.	Outside Diameter	Wt./100 pcs
1/4"	3/4"	0.7
3/8"	1"	1.5
1/2"	1 3/8"	3.9
5/8"	1 3/4"	7.7
3/4"	2"	11

**PS 6112 – Oversize Square Nut**

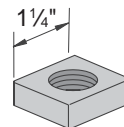

Size	Wt./100 pcs
1/4"-20	13
3/8"-16	14
1/2"-13	14
5/8"-11	12
3/4"-16	11
7/8"-11	10

# FASTENERS

Finish: Electro-galvanized Order By: No., Size and Finish

## PS 230 - Fender Washer



Size	Wt./100 pcs
1/4"	3.3
3/8"	3.0
1/2"	2.8

## PS 231 - Slot Adapter

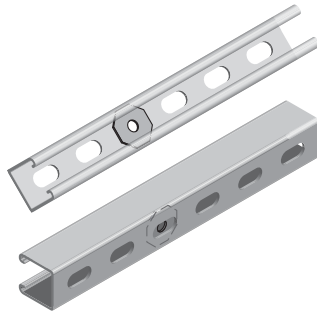
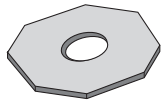

Size	Wt./100 pcs
1/4"	1.0
3/8"	1.5

## PS 517 - Channel Nut with Stud

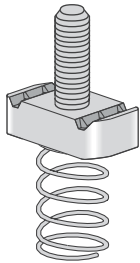

Use With: PS 200, PS 210 and PS 300 channel.

Size	Wt./100 pcs
1/4" x 1"	8.1
1/4" x 1 1/4"	8.3
1/4" x 1 1/2"	8.6
1/4" x 2"	9.1
3/8" x 1"	13.0
3/8" x 1 1/4"	14.0
3/8" x 1 1/2"	14.0
3/8" x 2"	15.0
1/2" x 1"	15.0
1/2" x 1 1/4"	16.0
1/2" x 1 1/2"	17.0
1/2" x 2"	19.0

## PS 3281 - Double Conveyor Adjusting Nut

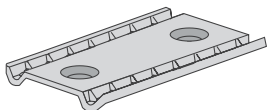

Use With: All 1 5/8" channel.

Size	Threads	Wt./100 pcs
3/8"	16	17.5

## PS 211 - Lock Washer



Size	Wt./ 100 pcs
1/4"	0.3
3/8"	0.7
1/2"	1.5

## PS 146 - Continuous Thread Rod

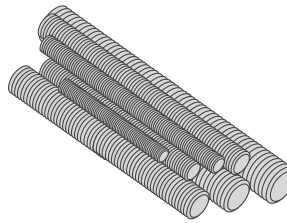

Finish: Plain or Electro-galvanized

Standard Length: 6' or 10';  
Other lengths available

Low Carbon Steel  
Fy = 32,000 psi minimum  
Ft = 52,000 psi minimum

Rod Size	Wt./100 pcs.		
	6' Lengths	10' Lengths	12' Lengths
1/4"	73	121	146
3/8"	175	292	350
1/2"	319	531	638
5/8"	504	840	1,008
3/4"	740	1,234	1,480

Load Information: See the technical data section, page 168

## PS 135 - Rod Coupling

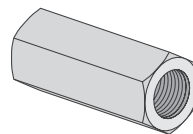

Rod Size	Max Load lbs.	Wt./ 100 pcs.
1/4"	240	2
3/8"	610	9
1/2"	1,130	10
5/8"	1,810	18
3/4"	2,710	28

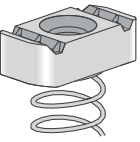

Finish: Electro-galvanized or Hot-dip galvanized **Order By:** No., Size and Finish

Metal Channel  
Fasteners  
Fittings  
Pipe & Conduit Clamps  
Electrical  
Concrete Inserts  
Solar Components  
Unipier®  
Jr. Channel  
Power-Angle  
Fiberglass  
Tech. Data

**PS LS - Clamping Nut with Long Spring**

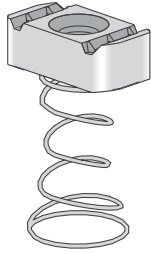

Size	Threads	Wt./100 pcs
1/4"	20	7.5
3/8"	16	10.2
1/2"	13	12.3
5/8"	11	15.8
3/4"	10	14.1

Use With: PS 100 and PS 150 Channel.

**PS RS - Clamping Nut with Long Spring**

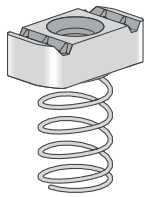

Size	Threads	Wt./100 pcs
#8-32	32	7.0
#10-24	24	7.2
#10-32	32	7.2
1/4"	20	7.1
5/16"	18	7.0
3/8"	16	9.9
1/2"	13	11.9

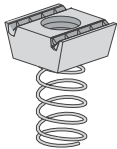

Size	Threads	Wt./100 pcs
5/8"	11	15.5
3/4"	10	13.8
7/8"	9	14.3

Use With: PS 200, PS 210 and PS 300 Channel.

**PS SS - Clamping Nut with Short Spring**

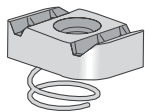

Size	Threads	Wt./100 pcs
#8-32	32	7.0
#10-24	24	7.0
#10-32	32	7.0
1/4"	20	6.9
5/16"	18	6.7
3/8"	16	9.6
1/2"	13*	8.8
5/8"	11*	11.5
3/4"	10*	10.0

Use With: PS 400, PS 500, PS 520, and PS 560 channel.  
\*PS SS 1/2" and PS SS 5/8" nuts have 3/8" body thickness.

**PS NS - Clamping Nut without Spring**

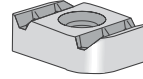

Size	Threads	Wt./100 pcs
#8-32	32*	8.0
#10-32		6.6
#10-24	24*	6.7
1/4"	20*	6.6
5/16"	18*	6.4
3/8"	16*	9.3
1/2"	13	11.4

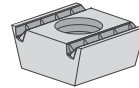

Size	Threads	Wt./100 pcs
5/8"	11	15.2
3/4"	10	13.0
7/8"	9	14.0

Use With: PS 100, PS 150, PS 200, PS 210 and PS 300 channel.

\*Can be used with PS 400, PS 500, PS 520 and PS 560 channel.

**PS NS S - Shallow Clamping Nut without Spring**

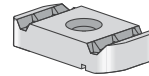

Size	Threads	Wt./100 pcs
1/2"	13	6.9
5/8"	11	9.7
3/4"	10	8.4

Use With: PS 500, PS 520, and PS 560 channel.

**PS TG - Top Grip™ Nut**

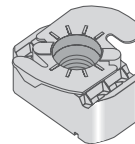

Part No.	Size	Threads	Wt./100 pcs
PSTG 1/4	1/4"	20	7
PSTG 3/8	3/8"	16	10
PSTG 1/2*	1/2"	13	8

Use With: All 1 1/2" Channel.

**PS ML - Missing Link Multi-Purpose Strut Fastener**

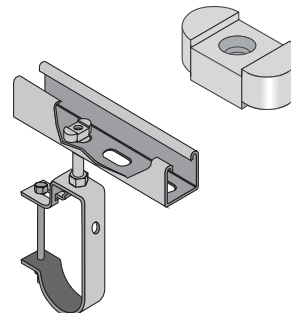

Use With: Any slotted channel.

Size	Threads	Wt./100 pcs
1/2"	13	6.9
5/8"	11	9.7
3/4"	10	8.4

# FASTENERS

Finish: Electro-galvanized Order By: No., Size and Finish

## PS 3500 $\frac{3}{8}$ " - $\frac{5}{8}$ " - Seismic Rod Stiffener

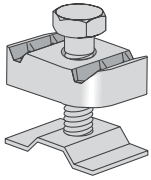

Part No.	Wt./100 pcs
PS 3500 $\frac{3}{8}$ "- $\frac{5}{8}$ "	16

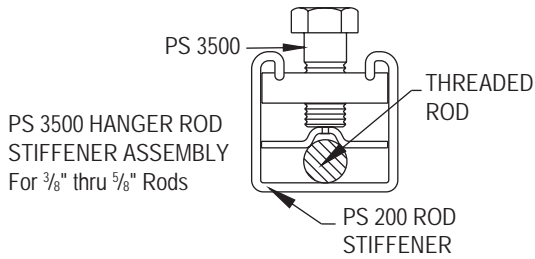

## PS 202 - Eyelet

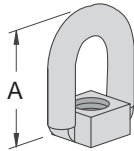

Rod Size	A	Stock Dia.	Max. Load lbs.	Wt. 100 pcs
$\frac{3}{8}$ "	$1\frac{3}{4}$ "	$\frac{3}{8}$ "	610	15
$\frac{1}{2}$ "				18

## PS 204 - Linked Eyelets

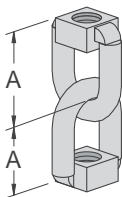

Rod Size	A	Stock Dia.	Max. Load lbs.	Wt./100 pcs
$\frac{3}{8}$ "	$1\frac{7}{16}$ "	$\frac{3}{8}$ "	610	23
$\frac{1}{2}$ "	$1\frac{3}{8}$ "			32

## PS KW - Kwik Washer™

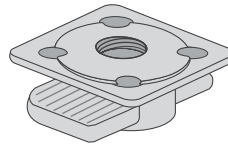

Size	Load Lbs	Wt./100 pcs
$\frac{1}{4}$ "	250	1.2
$\frac{3}{8}$ "	610	2.6
$\frac{1}{2}$ "	1,130	9.3

Use With: Any channel.

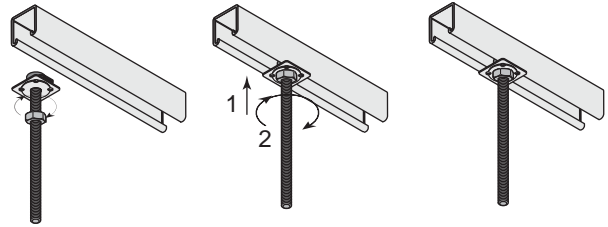

## PS 205 - Eyelet with Stud

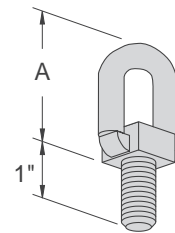

Thread Size	A	Stock Dia.	Max. Load lbs.	Wt./100 pcs
$\frac{3}{8}$ "	$1\frac{13}{16}$ "	$\frac{3}{8}$ "	610	16
$\frac{1}{2}$ "	$1\frac{3}{4}$ "			20

## PS 203 - Linked Eyelet with Stud

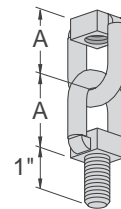

Rod Size	A	Stock Dia.	Max. Load lbs.	Wt./100 pcs
$\frac{3}{8}$ "	$1\frac{7}{16}$ "	$\frac{3}{8}$ "	610	27
$\frac{1}{2}$ "	$1\frac{3}{8}$ "			45

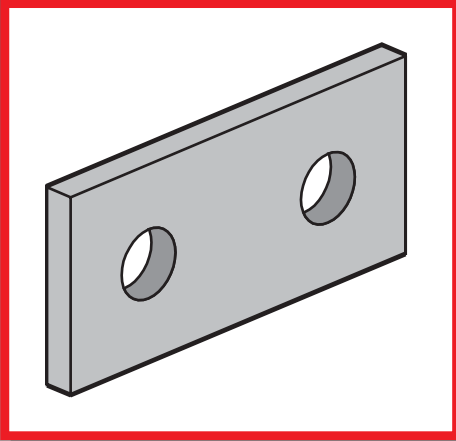

# FITTINGS

*Power-Strut has a wide variety of fittings to meet all of your application requirements*

## **MATERIAL:**

Fittings, unless noted, are made from hot-rolled, pickled and oiled steel plates, bar, strip or coil, and conform to one or more of the following specifications: ASTM specifications A575, A576, A635, A1011 SS GR 33, A1011 HSLAS GR 45 or A36. All fittings meet or exceed physical properties of ASTM A1011 GR 33. The pickling of the steel produces a smooth surface free from scale.

Many fittings are also available in stainless steel, aluminum and fiberglass. Consult factory for ordering information.

## **STANDARD DIMENSIONS:**

Standard dimensions on all fittings are as follows except where otherwise indicated:

- Fitting Thickness: 1/4" (ASTM A1011 SS GR 33) or 0.220" (ASTM A1011 HSLAS GR 45)
- Fitting Width: 1 5/8"
- Hole Diameter: 9/16"
- Hole Spacing: 1 7/8" on centers and 1 3/16" from ends.

## **STANDARD FINISH:**

All Power-Strut fittings are available in painted green, hot-dip galvanized, zinc dichromate or electro-galvanized finish.

## **ORDERING INFORMATION:**

When ordering, add the length or size and finish to the part number.  
See pages 8-9 for finish abbreviations and an example.

## **SET SCREW TORQUE:**

BOLT SIZE	1/4"-20	3/8"-16	1/2"-13	5/8"-11	3/4"-10	7/8"-9
Set Screw Torque In-Lbs	40	60	125	250	400	665

**Note:** Caution should be taken not to overtighten the set screw



# FITTINGS

Finish: Painted Green, Hot-dip galvanized, Zinc dichromate or Electro-galvanized Order By: No., Size and Finish

## PS 619 - Square Washer

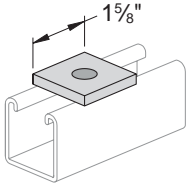

Note: Indicate rod size when ordering.  
For example, PS 619 1/2.

Rod Size	Hole Size	Wt./100 pcs
1/4"	11/32"	18
3/8"	7/16"	18
1/2"	9/16"	17
5/8"	11/16"	16
3/4"	13/16"	15

## PS 601 - Two-Hole Splice Plate

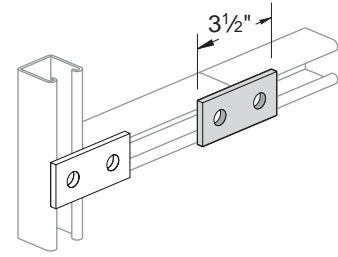

Weight/100 pcs: 38 lbs.

## PS 2504 - Guided Square Washer

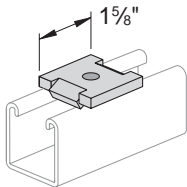

Note: Indicate rod size when ordering.  
For example, PS 2504 1/2.

Rod Size	Hole Size	Wt./100 pcs
1/4"	11/32"	18
3/8"	7/16"	18
1/2"	9/16"	17

## PS 602 - Three-Hole Splice Plate

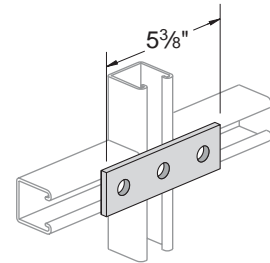

Weight/100 pcs: 50 lbs.

## PS 618 - Two-Hole Swivel Plate

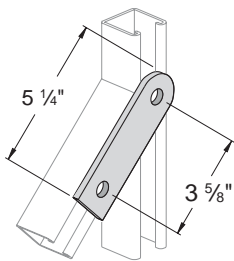

Weight/100 pcs: 55 lbs.

## PS 617 - Three-Hole Swivel Plate

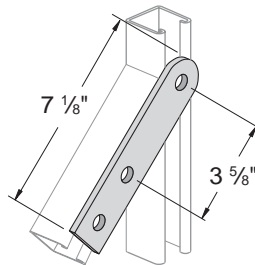

Weight/100 pcs: 75 lbs.

## PS 888 - Four-Hole Splice Plate

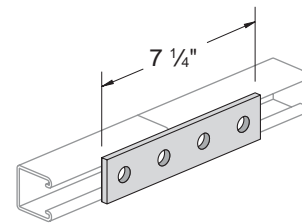

Weight/100 pcs: 78 lbs.

## PS 889 - Five-Hole Splice Plate

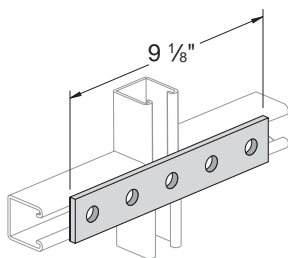

Weight/100 pcs: 94 lbs.

## PS 718 - Flat Angle Plate

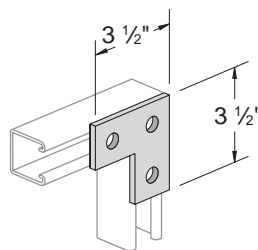

Weight/100 pcs: 58 lbs.

## PS 719 - Flat Angle Plate

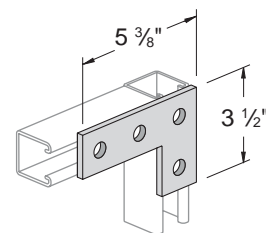

Weight/100 pcs: 80 lbs.

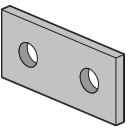

**Finish:** Painted Green, Hot-dip galvanized, Zinc dichromate or Electro-galvanized **Order By:** No., Size and Finish

**PS 620 – Two-Hole Connecting Plate**

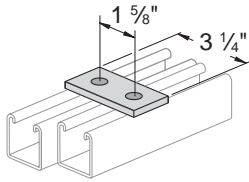

Weight/100 pcs: 35 lbs.

**PS 621 – Four-Hole Connecting Plate**

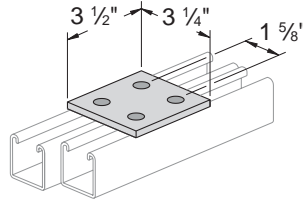

Weight/100 pcs: 73 lbs.

**PS 714 – Tee Plate**

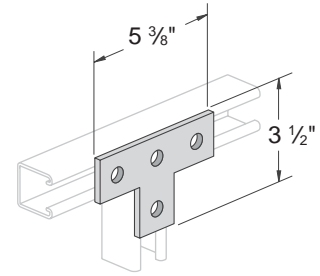

Weight/100 pcs: 80 lbs.

**PS 712 – Cross Plate**

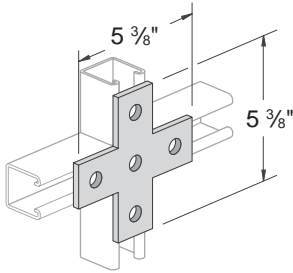

Weight/100 pcs: 105 lbs.

**PS 744 – Flat Corner Connector**

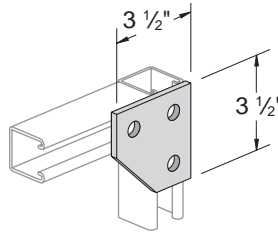

Weight/100 pcs: 70 lbs.

**PS 750 – Four-Hole Corner Connector**

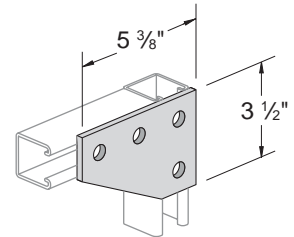

Weight/100 pcs: 105 lbs.

**PS 2190 – Flat Corner Connector**

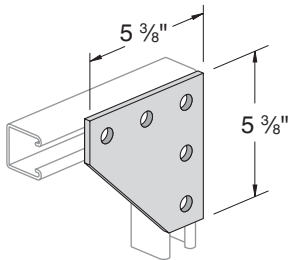

Weight/100 pcs: 150 lbs.

**PS 925 – Three-Hole Joint Connector**

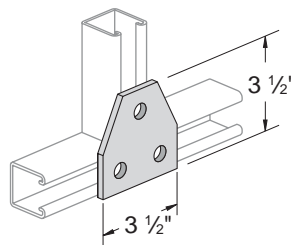

Weight/100 pcs: 70 lbs.

**PS 747 – Symmetrical Four-Hole Connector**

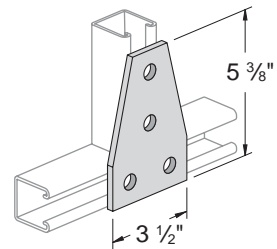

Weight/100 pcs: 105 lbs.

**PS 854 – Flat Connector**

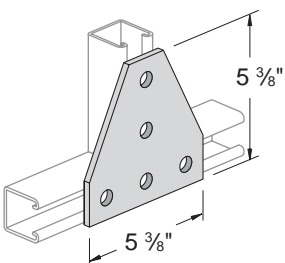

Weight/100 pcs: 148 lbs.

**PS 2112 – Cross Connector**

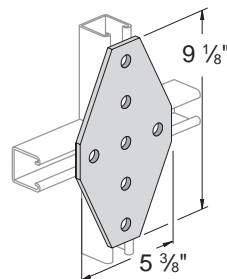

Weight/100 pcs: 240 lbs.

**PS 822 – Double 45° Connector**

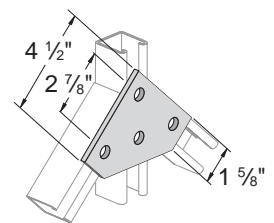

Weight/100 pcs: 112 lbs.

# FITTINGS

Finish: Painted Green, Hot-dip galvanized, Zinc dichromate or Electro-galvanized Order By: No., Size and Finish

## PS 921 - One-Hole Angle

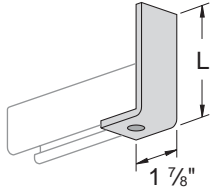

Part No.	L	Wt./100 pcs
PS 921 A	3 7/8"	61
PS 921 B	5 7/8"	84
PS 921 C	7 7/8"	107
PS 921 D	9 7/8"	130

## PS 806 - Self-Aligning Two-Hole Angle

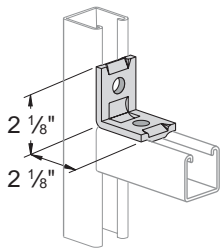

Weight/100 pcs: 40 lbs.

## PS 605 - Three-Hole Corner Angle

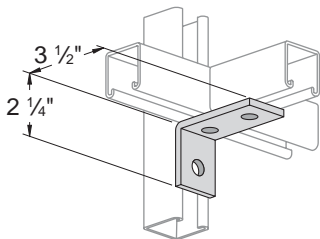

Weight/100 pcs: 58 lbs.

## PS 603 - Two-Hole End Angle

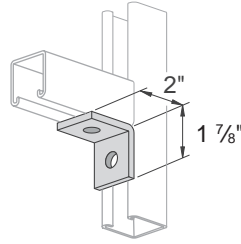

Weight/100 pcs: 38 lbs.

## PS 2144 - Corner Angle

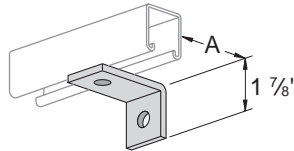

A	Wt./100 pcs
3"	49
3 1/2"	54
4"	61

## PS 2520 - Slotted 90° Angle

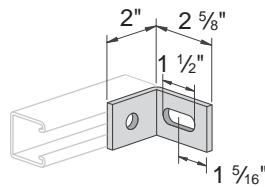

Weight/100 pcs: 42 lbs.

## PS 604 - Two-Hole Corner Angle

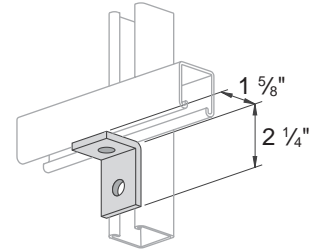

Weight/100 pcs: 38 lbs.

## PS 763 - Slotted Adjustment Angle

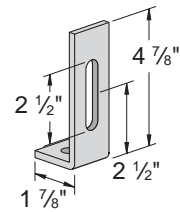

Weight/100 pcs: 65 lbs.

## PS 764 - Slotted Adjustment Angle

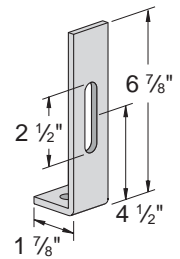

Weight/100 pcs: 85 lbs.

## PS 2545 - Slotted 90° Angle

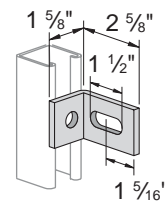

Weight/100 pcs: 38 lbs.

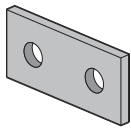

**Finish:** Painted Green, Hot-dip galvanized, Zinc dichromate or Electro-galvanized **Order By:** No., Size and Finish

Metal Channel  
Fasteners  
Fittings  
Pipe & Conduit Clamps  
Electrical  
Concrete Inserts  
Solar Components  
Unipier®  
Jr. Channel  
Power-Angle  
Fiberglass  
Tech. Data

**PS 3049 - Two-Hole Slotted 90° Angle**

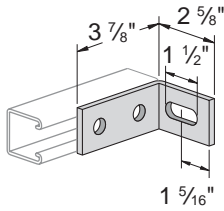

Weight/100 pcs: 66 lbs.

**PS 607 - Four-Hole Corner Angle**

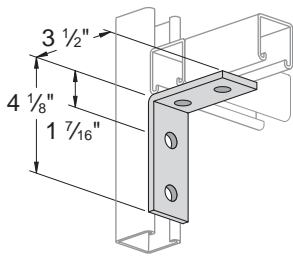

Weight/100 pcs: 78 lbs.

**PS 614 - Four-Hole Joint Angle Connector**

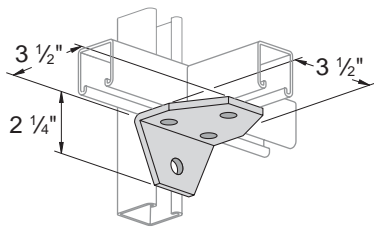

Weight/100 pcs: 103 lbs.

**PS 716 R or L - Angle Tee Plate**

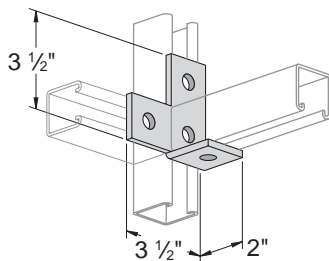

**Note:**  
Specify R (Right) or L (Left) Right Hand Illustrated

Weight/100 pcs: 80 lbs.

**PS 606 - Three-Hole Corner Angle**

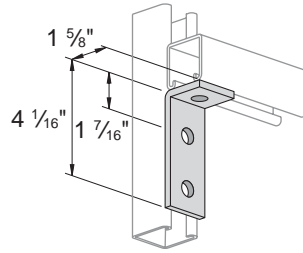

Weight/100 pcs: 58 lbs.

**PS 660 - Four-Hole Corner Angle**

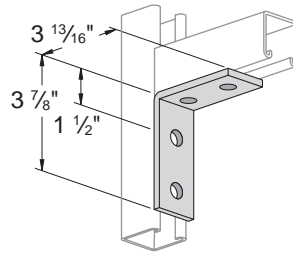

Weight/100 pcs: 78 lbs.

**PS 615 - Five-Hole Joint Angle Connector**

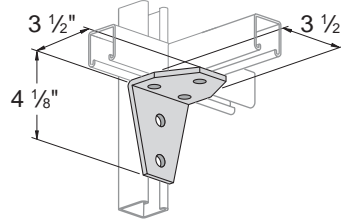

Weight/100 pcs: 135 lbs.

**PS 713 - Cross Plate Angle**

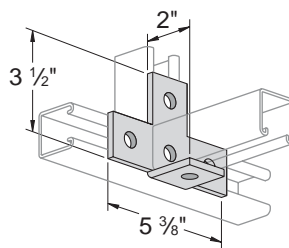

Weight/100 pcs: 105 lbs.

**PS 745 - Three-Hole Corner Angle**

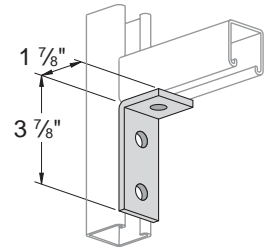

Weight/100 pcs: 58 lbs.

**PS 3373 - Universal Corner Connector**

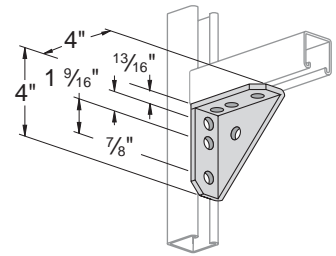

Weight/100 pcs: 134 lbs.

**PS 720 R or L - Angle Plate Connector**

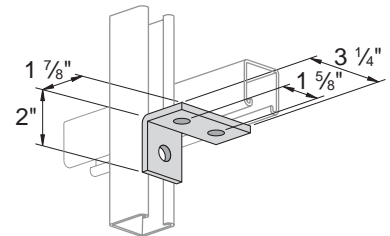

**Note:**  
Specify R (Right) or L (Left) Right Hand Illustrated

Weight/100 pcs: 55 lbs.

**PS 715 - Tee Plate 90° Angle**

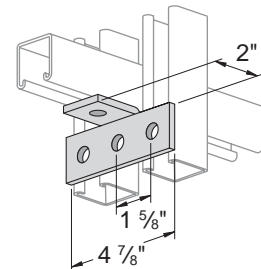

Weight/100 pcs: 71 lbs.

# FITTINGS

Finish: Painted Green, Hot-dip galvanized, Zinc dichromate or Electro-galvanized **Order By:** No., Size and Finish

**PS 689A, PS 689B -**  
Double-Slotted Corner Connector

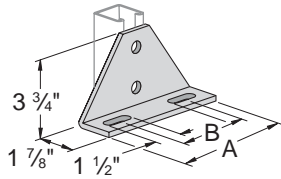

Part No.	A	B	Wt./100 pcs
PS 689 A	6 5/8"	4"	190
PS 689 B	8 5/8"	6"	242

**PS 927 -** Five-Hole Corner Connector

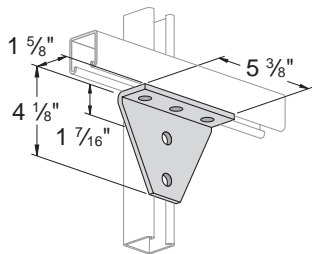

Weight/100 pcs: 154 lbs.

**PS 2007 R or L -** Six-Hole Corner Connector

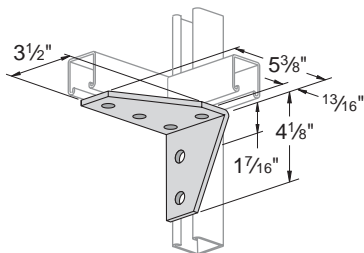

**Note:**  
Specify R (Right) or L (Left) Right Hand Illustrated

Weight/100 pcs: 160 lbs.

**PS 748 -** Four-Hole Corner Joint Connector

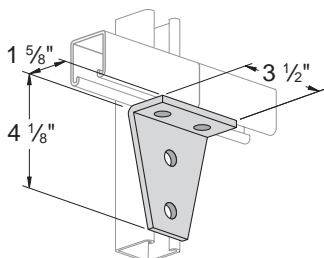

Weight/100 pcs: 105 lbs.

**PS 746 -** Three-Hole Corner Joint Connector

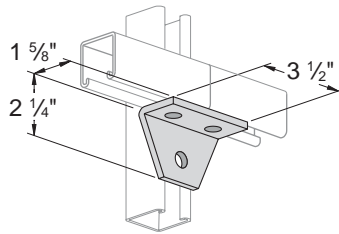

Weight/100 pcs: 70 lbs.

**PS 752 R or L -** Four-Hole Corner Connector

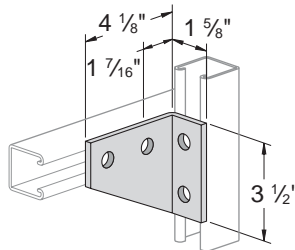

**Note:**  
Specify R (Right) or L (Left) Right Hand Illustrated

Weight/100 pcs: 105 lbs.

**PS 3326 R or L -** Six-Hole Gusseted Corner Connector

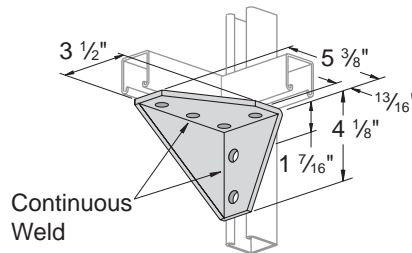

**Note:**  
Specify R (Right) or L (Left) Right Hand Illustrated

Weight/100 pcs: 230 lbs.

**PS 2113 -** Slotted Corner Connector

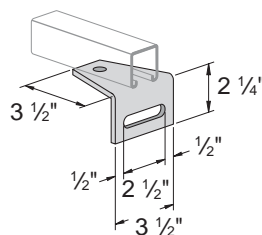

Weight/100 pcs: 97 lbs.

**PS 622 -** Four-Hole Corner Connector

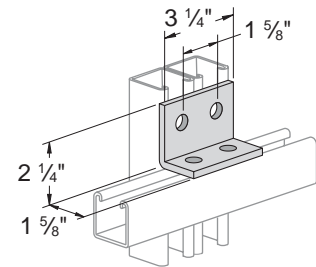

Weight/100 pcs: 75 lbs.

**PS 624 -** Two-Hole Closed Angle Connector

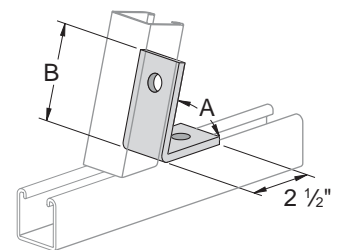

"B" In.	"A" Angle
3"	37 1/2°
3 1/8"	45°
3 1/16"	52 1/2°
3 3/8"	60°
3 1/2"	67 1/2°
3 3/4"	75°
3 7/8"	82 1/2°

Weight/100 pcs: 58 lbs.

**PS 926 -** Strut Brace

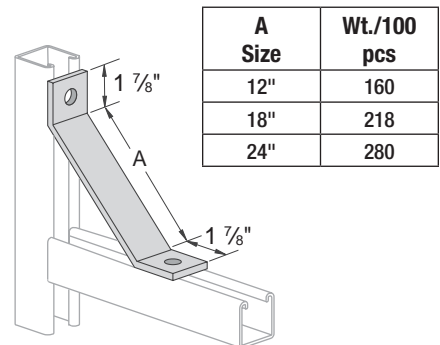

A Size	Wt./100 pcs
12"	160
18"	218
24"	280

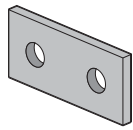

**Finish:** Painted Green, Hot-dip galvanized, Zinc dichromate or Electro-galvanized **Order By:** No., Size and Finish

**PS 633 – Two-Hole Open Angle Connector**

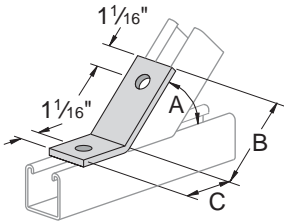

"A" Degree	"B" In.	"C" In.
82½°	3⅞"	1⅞"
75°	3⅞"	
67½°	3½"	1¾"
60°	3⅜"	1⅞"
52½°	3¼"	2⅞"
45°	3"	2⅝"
37½°	2⅞"	2⅝"
30°	3¼"	2⅞"
22½°	3⅞"	
15°	3⅞"	
7½°	3⅞"	

Weight/100 pcs: 58 lbs.

**PS 2054 – Corner Connector**

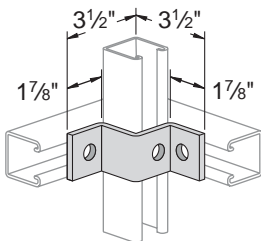

Use With: PS 200, PS 210

Weight/100 pcs: 66 lbs.

**PS 810 – Diagonal Tube Brace**

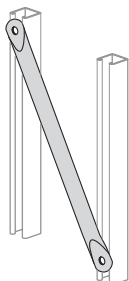

Part No.	A Size	Wt./100 pcs
PS 810 36	3'-0"	205
PS 810 42	3'-6"	237
PS 810 48	4'-0"	270

**Note:**  
30° to 60° angle between the brace and channel is recommended for maximum effect.  
**Material:** 1" dia. electric welded tubing  
**Stock Thickness:** (.075) 14 ga.

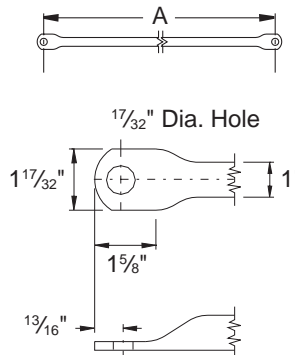

**PS 793 – Four-Hole Closed Angle Connector**

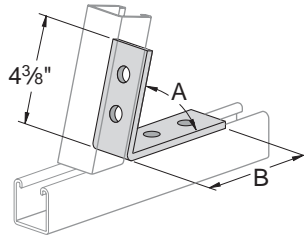

"A" Angle	"B" In.
37½°	4⅞"
45°-	4⅞"
52½°	
60°	5"
67½°	5⅞"
75°	
82½°	

Weight/100 pcs: 100 lbs.

**PS 9401 – Double Adjustable Brace**

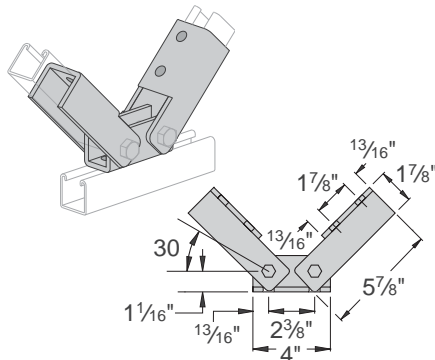

Weight/100 pcs: 307 lbs.

**PS 781 – Four-Hole Open Angle Connector**

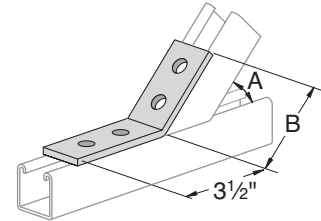

"A" Angle	"B" In.
7½°	3¾"
15°	
22½°	
30°	3⅞"
37½°	
45°	
52½°	
60°	3⅝"
67½°	
75°	
82½°	

Weight/100 pcs: 78 lbs.

**PS 9400 – Adjustable Brace**

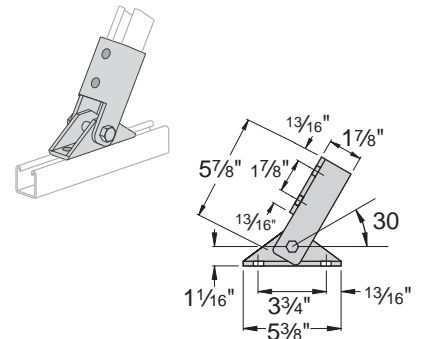

Weight/100 pcs: 307 lbs.

**PS 9402 – Two-Hole Hinge Connector**

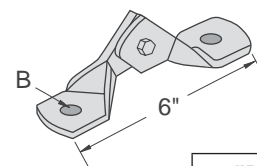

"B" Bolt Size	Wt./100 pcs
½"	108
⅝"	107
¾"	106

# FITTINGS

Finish: Painted Green, Hot-dip galvanized, Zinc dichromate or Electro-galvanized **Order By:** No., Size and Finish

## PS 9404 - Four-Hole Hinge Connector

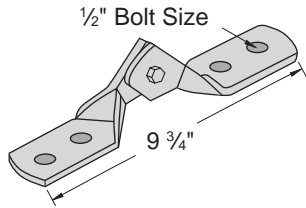

Part No.	Wt./100 pcs
PS 9404-1/2"	126

## PS 692 - 1 5/8" Offset "Z" Connector

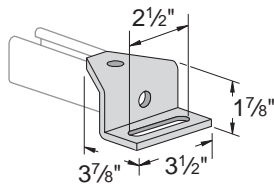

Weight/100 pcs: 102 lbs.

## PS 2523 - Offset Adjustable "Z" Connector

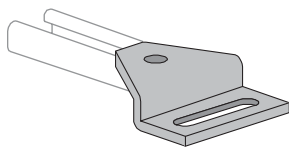

Use With: PS 500, PS 520, & PS 560

Weight/100 pcs: 70 lbs.

## PS 2532 - Shelf Attachment "Z"

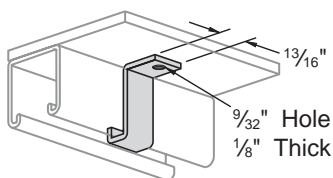

Stock Thickness: 1/8"

Use With: PS 200, PS 210

Weight/100 pcs: 9 lbs.

## PS 9403 - Three-Hole Hinge Connector

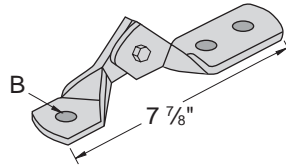

"B" Bolt Size	Wt./100 pcs
1/2"	108
5/8"	107
3/4"	106

Hinge Connect or Auto-Alignment Guides -

The unique edges of the two hinges have been designed to provide an alignment guide for 0°, 45° and 90° as shown in the drawings below.

This eliminates the need for measuring gages.

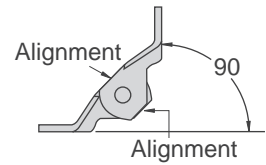
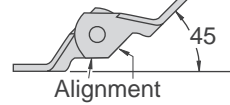
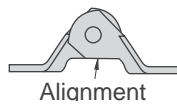

- Each half of the hinge is formed and welded for maximum strength.
- Hinged with Grade 5 bolt for superior strength.
- The nylon insert locknut prevents loosening of the hinge.

## PS 812 - 45° Diagonal Tube Brace

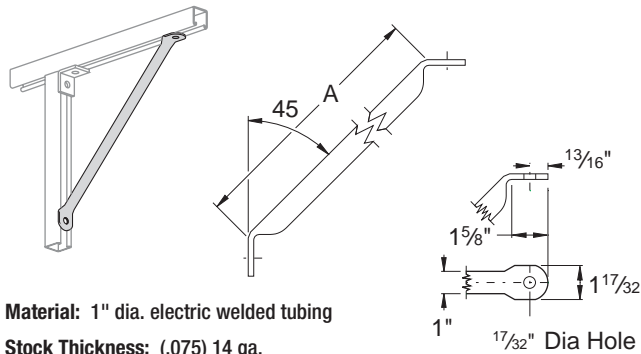

Material: 1" dia. electric welded tubing

Stock Thickness: (.075) 14 ga.

A Size	Wt./100 pcs
12"	88
18"	116
24"	149
30"	181
36"	214

Design Load:  
Tension = 300 lbs.  
Comp. = 1,500 lbs.

## PS 3060 - Offset Connector

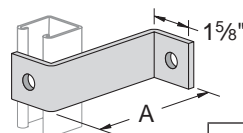

A	Wt./100 pcs
4"	81
5"	92
6"	104
7"	115
8"	127

## PS 647 - 1 7/8" Offset "Z" Connector

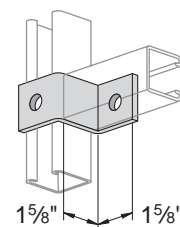

Use With: PS 200, PS 210

Weight/100 pcs: 55 lbs.

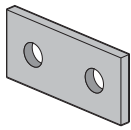

**Finish:** Painted Green, Hot-dip galvanized, Zinc dichromate or Electro-galvanized **Order By:** No., Size and Finish

Metal Channel  
Fasteners  
Fittings  
Pipe & Conduit Clamps  
Electrical  
Concrete Inserts  
Solar Components  
Unipier®  
Jr. Channel  
Power-Angle  
Fiberglass  
Tech. Data

**PS 756 - "Z" Support**

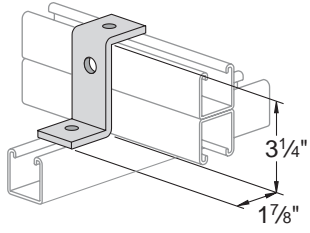

**Use With:** PS 100, PS 200 2T3, PS 210 2T3  
Weight/100 pcs: 70 lbs.

**PS 2601 - "Z" Support**

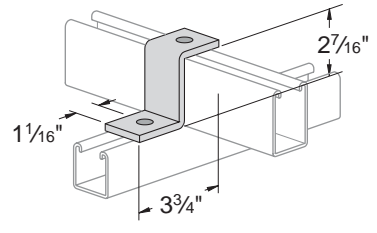

**Use With:** PS 150  
Weight/100 pcs: 70 lbs.

**PS 611 - "Z" Support**

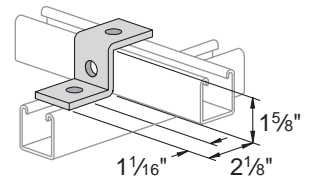

**Use With:** PS 200, PS 210  
Weight/100 pcs: 55 lbs.

**PS 711 - "Z" Support**

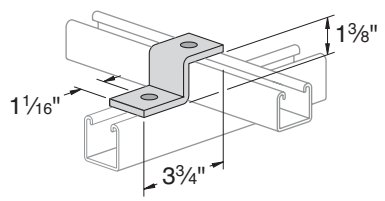

**Use With:** PS 300  
Weight/100 pcs: 53 lbs.

**PS 612 - "Z" Support**

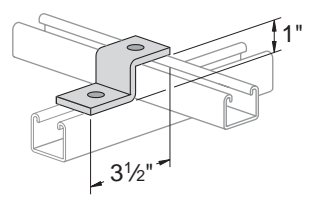

**Use With:** PS 400  
Weight/100 pcs: 47 lbs.

**PS 928 - "Z" Support**

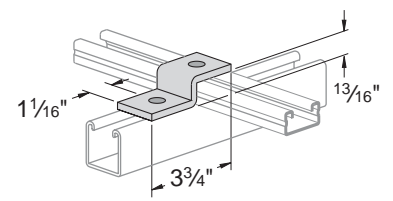

**Use With:** PS 500, PS 520 and PS 560  
Weight/100 pcs: 47 lbs.

**PS 609 - Two-Hole Offset Plate Connector**

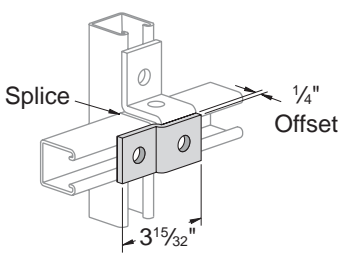

Weight/100 pcs: 38 lbs.

**PS 679 - "U" Support**

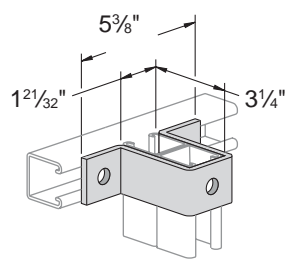

**Use With:** PS 100, PS 200 2T3, PS 210 2T3  
Weight/100 pcs: 128 lbs.

**PS 2648 - "U" Support**

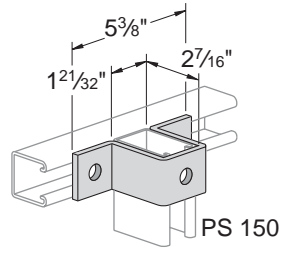

**Use With:** PS 150  
Weight/100 pcs: 108 lbs.

**PS 613 - "U" Support**

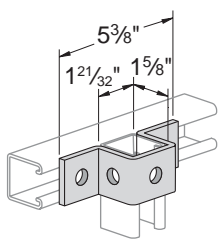

**Use With:** PS 200, PS 210  
Weight/100 pcs: 88 lbs.

**PS 2119 - "U" Support**

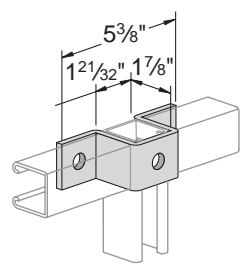

**Use With:** PS 200, PS 210  
Weight/100 pcs: 95 lbs.

**PS 710 - "U" Support**

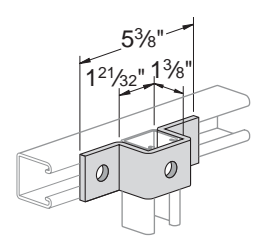

**Use With:** PS 300  
Weight/100 pcs: 84 lbs.



# FITTINGS

Finish: Painted Green, Hot-dip galvanized, Zinc dichromate or Electro-galvanized **Order By:** No., Size and Finish

## PS 978 - "U" Support

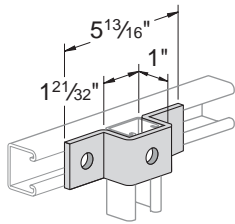

Use With: PS 400

Weight/100 pcs: 71 lbs.

## PS 929 - "U" Support

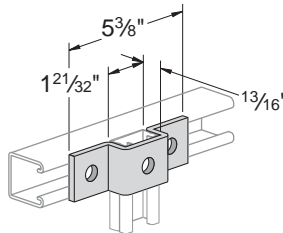

Use With: PS 500, PS 520 and PS 560

Weight/100 pcs: 71 lbs.

## PS 721 - "U" Support

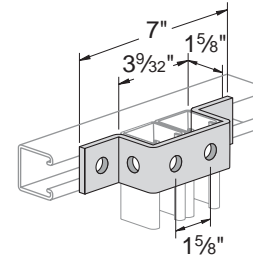

Use With: PS 100, PS 200 2T3, PS 210 2T3

Weight/100 pcs: 105 lbs.

## PS 678 - Three-Hole "U" Support

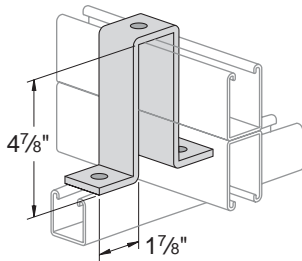

Use With: PS 150 2T3

Weight/100 pcs: 197 lbs.

## PS 687A, PS 687B & PS 687C - Slotted "U" Support

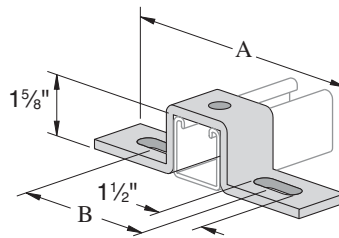

Use With: PS 200, PS 210

Order No.	'A' Length	'B' Length	Wt./100 pcs
PS 687A	7 1/4"	4 1/8"	105
PS 687B	8 1/2"	5 3/8"	120
PS 687C	10 3/8"	7 1/4"	130

## PS 677 - Cup Support for Standard Single Strut

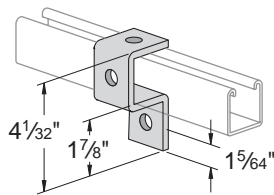

Use With: PS 200, PS 210

Weight/100 pcs: 76 lbs.

## PS 733 - Six-Hole "U" Support

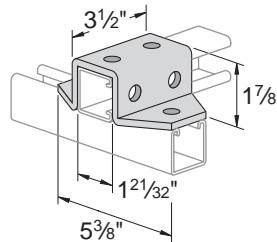

Use With: PS 200, PS 210

Weight/100 pcs: 171 lbs.

## PS 734 - Eight-Hole "U" Support

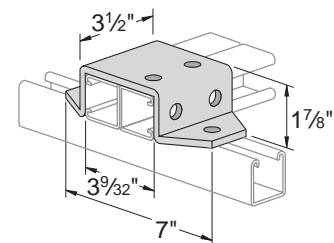

Use With: PS 200 2T3

Weight/100 pcs: 209 lbs.

## PS 735 - Eight-Hole "U" Support

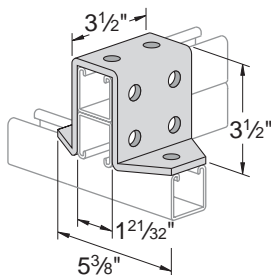

Use With: PS 200 2T3

Weight/100 pcs: 257 lbs.

## PS 709 - Three-Hole Offset Plate Connection

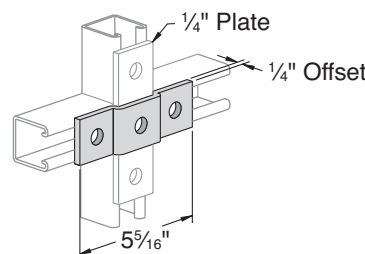

Weight/100 pcs: 58 lbs.

## PS 623 - Saddle Washer

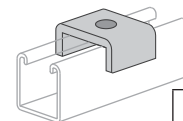

Bolt Size	Wt./100 pcs
1/4"	14
3/8"	
1/2"	
5/8"	13
3/4"	

Weight/100 pcs: 265 lbs.

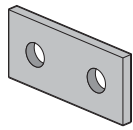

**Finish:** Painted Green, Hot-dip galvanized, Zinc dichromate or Electro-galvanized **Order By:** No., Size and Finish

Metal Channel  
Fasteners  
Fittings  
Pipe & Conduit Clamps  
Electrical  
Concrete Inserts  
Solar Components  
Unipier®  
Jr. Channel  
Power-Angle  
Fiberglass  
Tech. Data

**PS 644 - Two-Hole Splice Clevis**

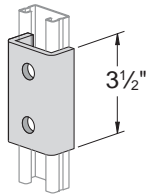

Use With: PS 500, PS 520 and PS 560

Weight/100 pcs: 85 lbs.

**PS 631 - Two-Hole Splice Clevis**

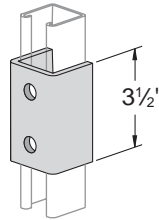

Use With: PS 200, PS 210

Weight/100 pcs: 128 lbs.

**PS 645 - Three-Hole Splice Clevis**

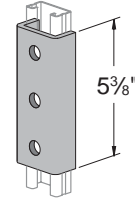

Use With: PS 500, PS 520 and PS 560

Weight/100 pcs: 130 lbs.

**PS 629 - Three-Hole Splice Clevis**

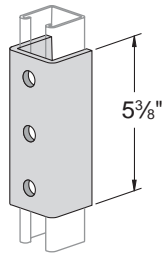

Use With: PS 200 and PS 210

Weight/100 pcs: 197 lbs.

**PS 616, PS 646 - Four-Hole Splice Clevis**

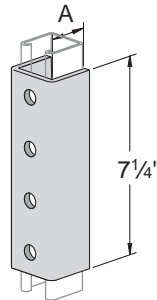

Part No.	A	For Use With	Wt./100 pcs
PS 616	1 1/16"	PS 200, PS 210	265
PS 646	1 3/16"	PS 500, PS 560	176
PS 616-100	3 3/16"	PS 100	390
PS 616-150	2 3/8"	PS 150	390

**PS 804 - Slotted Joiner**

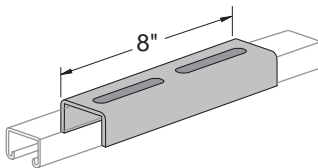

Stock Thickness: (.105)

Use With: PS 400S, PS 500S, PS 520S and PS 560S

Note: Order PS 6072 screws & PS 6108 nuts separately.

Weight/100 pcs: 80 lbs.

**PS 704 - Slotted Joiner**

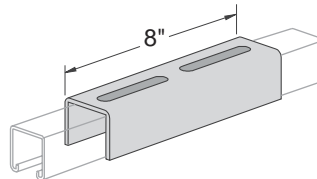

Stock Thickness: (.105)

Use With: PS 200S, PS 210S

Note: Order PS 6072 screws & PS 6108 nuts separately.

Weight/100 pcs: 197 lbs.

**PS 1004 - Slotted Joiner**

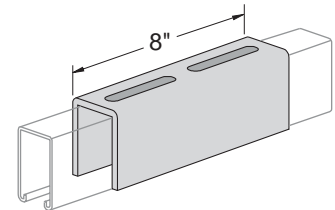

Stock Thickness: (.105)

Use With: PS 150S

Note: Order PS 6072 screws & PS 6108 nuts separately.

Weight/100 pcs: 140 lbs.

**PS 993 - Inside Clevis Hanger**

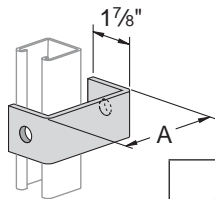

A Size	Wt./100 pcs
4"	78
5"	89
6"	101
7"	112
8"	124

**PS 922 R or L - Two-Hole Corner Connector**

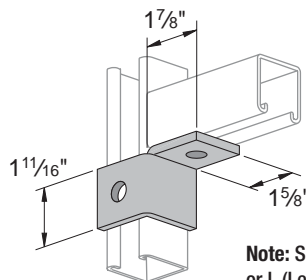

Note: Specify R (Right) or L (Left) Right Hand Illustrated

Weight/100 pcs: 60 lbs.

**PS 2117 R or L - Wrap-Around Corner Connector**

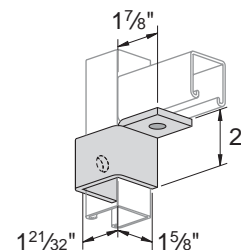

Note: Specify R (Right) or L (Left) Right Hand Illustrated

Weight/100 pcs: 75 lbs.

# FITTINGS

Finish: Painted Green, Hot-dip galvanized, Zinc dichromate or Electro-galvanized **Order By:** No., Size and Finish

**PS 2128 R or L** – Four-Hole Corner Connector

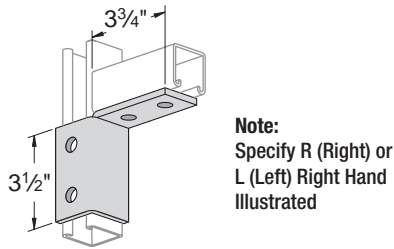

Weight/100 pcs: 119 lbs.

**PS 665** – Four-Hole Double Corner Connector

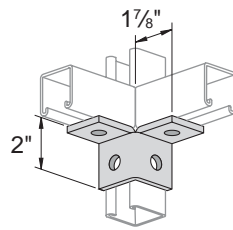

Weight/100 pcs: 76 lbs.

**PS 923** – Five-Hole Double Wing Connector

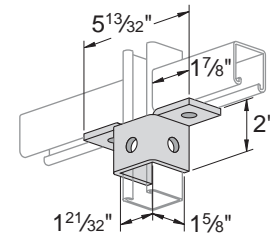

Weight/100 pcs: 93 lbs.

**PS 666** – Six-Hole Double Corner Connector

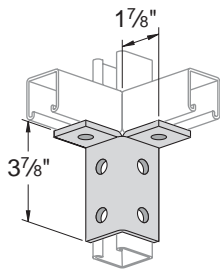

Weight/100 pcs: 115 lbs.

**PS 667** – Eight-Hole Double Corner Connector

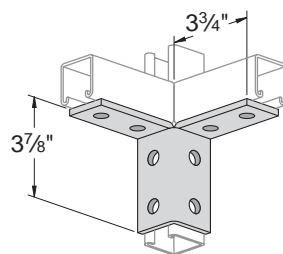

Weight/100 pcs: 155 lbs.

**PS 821** – Eight-Hole Double Wing Connector

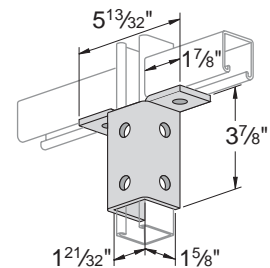

Weight/100 pcs: 150 lbs.

**PS 913** – Ten-Hole Double Wing Connector

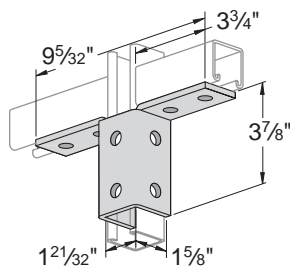

Weight/100 pcs: 193 lbs.

**PS 2129 R or L** – Single Corner Gusseted Connector

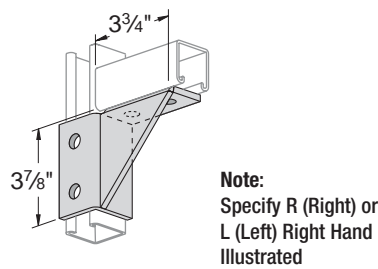

Weight/100 pcs: 176 lbs.

**PS 945** – Ten-Hole Gusseted Double Wing Connector

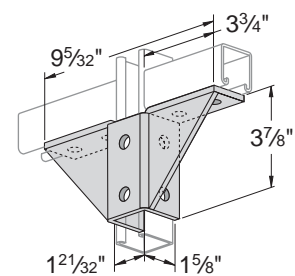

Weight/100 pcs: 274 lbs.

**PS 943** – Eight-Hole Gusseted Double Corner Connector

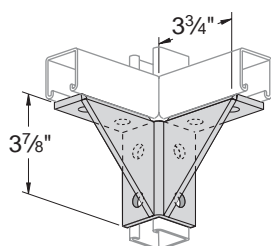

Weight/100 pcs: 217 lbs.

**PS 2514** – Eight-Hole Gusseted Double Corner Connector

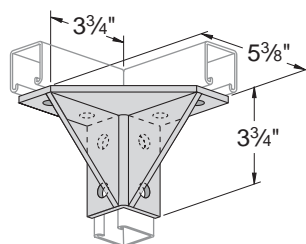

Weight/100 pcs: 315 lbs.

**PS 668** – Six-Hole Triple Wing Connector

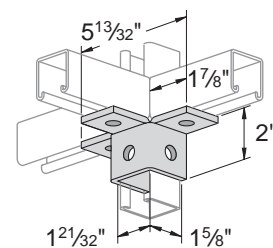

Weight/100 pcs: 113 lbs.

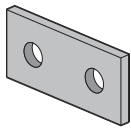

**Finish:** Painted Green, Hot-dip galvanized, Zinc dichromate or Electro-galvanized **Order By:** No., Size and Finish

**PS 670 - Nine-Hole Triple Wing Connector**

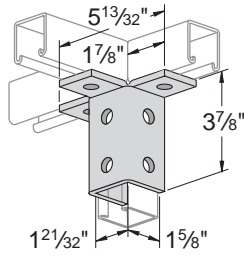

Weight/100 pcs: 177 lbs.

**PS 669 - Twelve-Hole Triple Wing Connector**

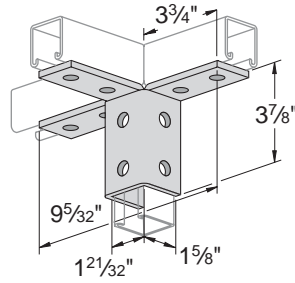

Weight/100 pcs: 230 lbs.

**PS 3041 - Double-Column Post Base**

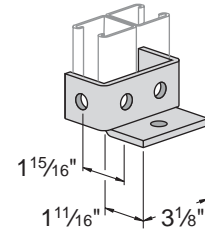

Use With: PS 100, PS 200 2T3, and PS 210 2T3.

Weight/100 pcs: 116 lbs

**PS 3013, PS 3013 SQ - Post Base**

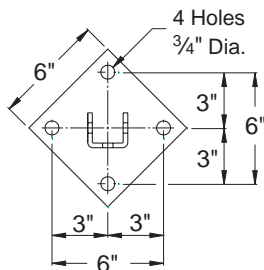
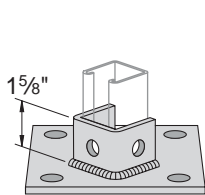

**(PS 3013)**

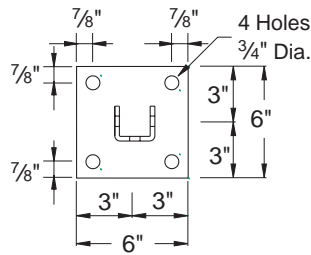

**(PS 3013 SQ)**

Weight/100 pcs: 307 lbs.

**PS 3040 - Post Base**

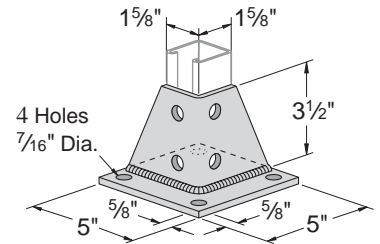

Weight/100 pcs: 297 lbs.

**PS 3025, PS 3025 FL - Post Base**

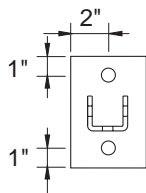
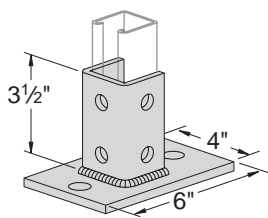

**(PS 3025)**

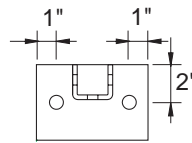

**(PS 3025 FL)**

Weight/100 pcs: 358 lbs.

**PS 2064 - Double-Column Post Base**

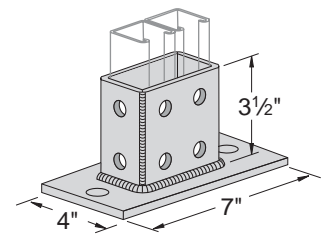

**PS 3033, PS 3033 SQ - Post Base**

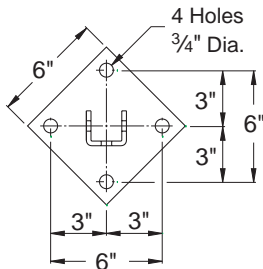
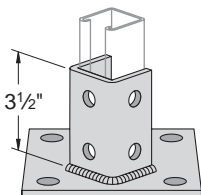

**(PS 3033)**

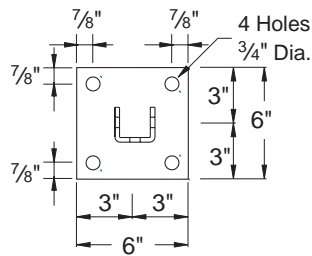

**(PS 3033 SQ)**

Weight/100 pcs: 373 lbs.

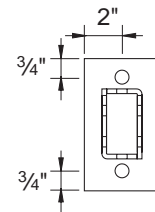

Use With: PS 100, PS 200 2T2, PS 200 2T3, PS 200 2T4 and PS 200 2T5

Weight/100 pcs: 311 lbs.

# FITTINGS

Finish: Painted Green, Hot-dip galvanized, Zinc dichromate or Electro-galvanized **Order By:** No., Size and Finish

## PS 3029 - Double-Column Post Base

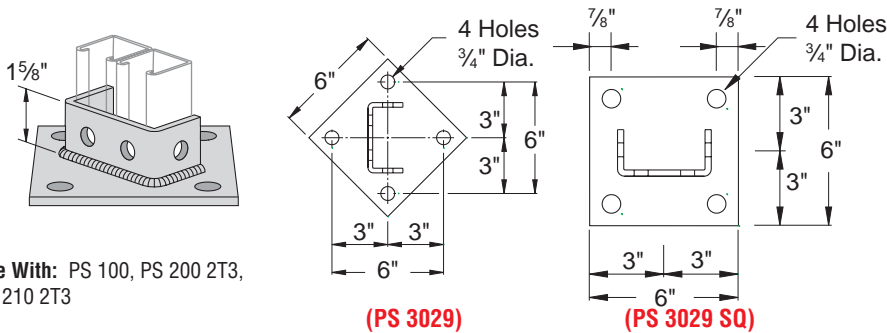

Use With: PS 100, PS 200 2T3, PS 210 2T3

(PS 3029)

(PS 3029 SQ)

Weight/100 pcs: 325 lbs.

## PS 3064 - Double-Column Post Base

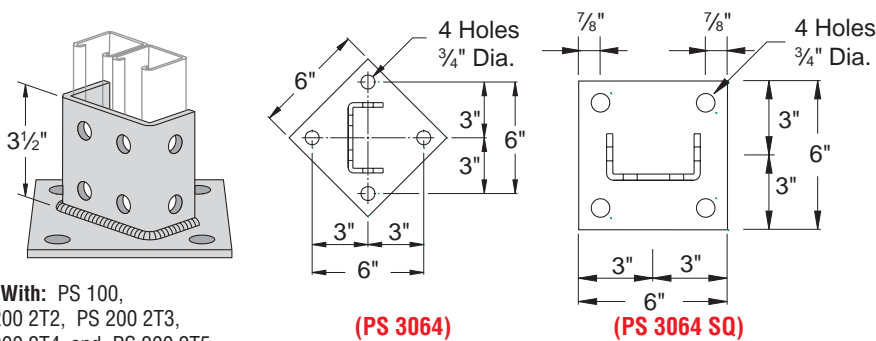

Use With: PS 100, PS 200 2T2, PS 200 2T3, PS 200 2T4 and PS 200 2T5

(PS 3064)

(PS 3064 SQ)

Weight/100 pcs: 408 lbs.

## PS 2521 - Two-Wheel Trolley

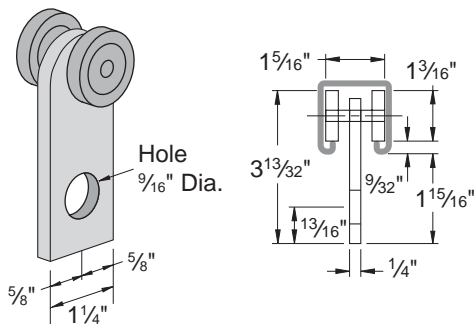

**Material:** Carbon Steel Wheels have stainless steel ball bearings

**Finish:** Electro-Galvanized

**Use With:** PS 200

**Load Rating:** 300 lbs.

FPM	RPM	Design Load In PS 200 Lbs
180	600	150
90	300	225
30	100	437

Weight/100 pcs: 46 lbs.

## PS 2528 - Trolley Beam Standard Support

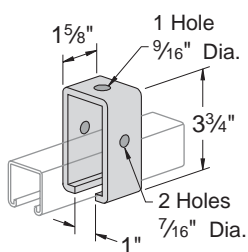

Use With: PS 200, PS 210  
**Load Rating:** 600 lbs.

Weight/100 pcs: 102 lbs.

## PS 2528 1 - Trolley Beam Heavy Support and Track Joinder

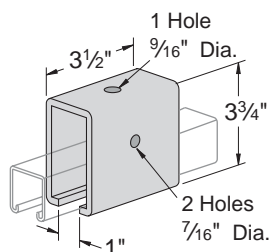

Use With: PS 200, PS 210  
**Load Rating:** 2,500 lbs.

Weight/100 pcs: 220 lbs.

## PS 2524 - Two-Bearing Light Duty Trolley

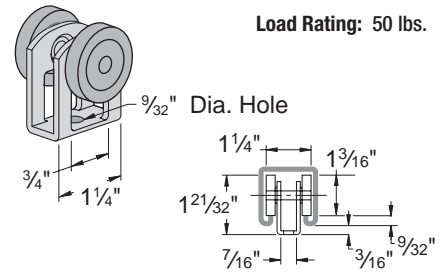

**Load Rating:** 50 lbs.

Weight/100 pcs: 21 lbs.  
Trolleys only available in Electro-galvanized

## PS 2525 - Four-Bearing Light Duty Trolley

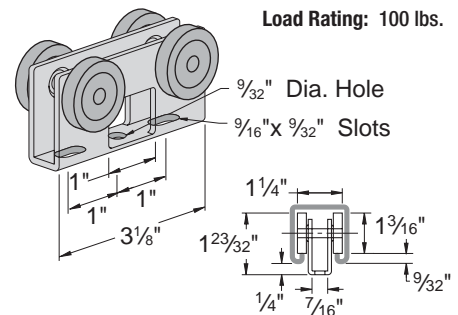

**Load Rating:** 100 lbs.

Weight/100 pcs: 55 lbs.

## PS 2522 - Four-Wheel Trolley

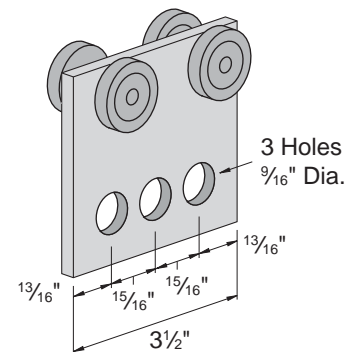

**Material:** Carbon Steel Wheels have stainless steel ball bearings

**Finish:** Electro-Galvanized

**Use With:** PS 200

**Load Rating:** 600 lbs.

FPM	RPM	Design Load In PS 200 Lbs
180	600	300
90	300	450
30	100	600

Weight/100 pcs: 110 lbs.

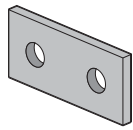

Finish: Painted Green, Hot-dip galvanized or Electro-galvanized Order By: No., Size and Finish

Metal Channel  
Fasteners  
Fittings  
Pipe & Conduit Clamps  
Electrical  
Concrete Inserts  
Solar Components  
Unipier®  
Jr. Channel  
Power-Angle  
Fiberglass  
Tech. Data

**PS 626 - Pipe Stop**

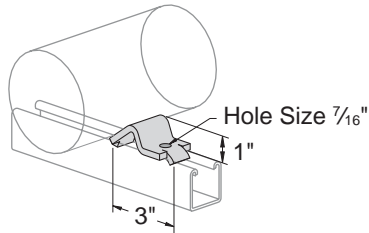

Clamp Requires bolt and channel nut sold separately.

Note: For use with 2" to 8" Pipe

Weight/100 pcs: 40 lbs.

**PS 651 - Reversible Channel Bracket**

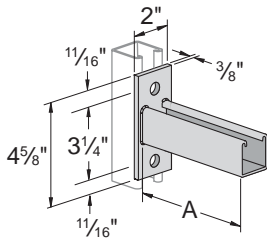

A Size	Uniform Load*	Wt./100 pcs
6"	1,200	185
12"	600	293
18"	400	401
24"	300	509
*Mounted on 12 Ga. Channel		

**PS 708 - Single Channel Bracket Support**

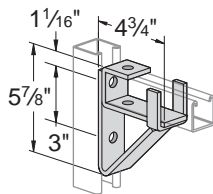

Use With: PS 200,  
PS 210,  
PS 500 2T3

Design Moment on Upright Channel:

- 16 ga. channel 3,200 in.-lbs.,
- 14 ga. channel 4,400 in.-lbs.
- 12 ga. channel 5,100 in.-lbs.

Note:  
Moment is for fitting only.  
Channel may determine overall capacity.

Weight/100 pcs: 235 lbs.

**PS 661 T1, PS 661 T2 - Wrap-Around Channel Bracket**

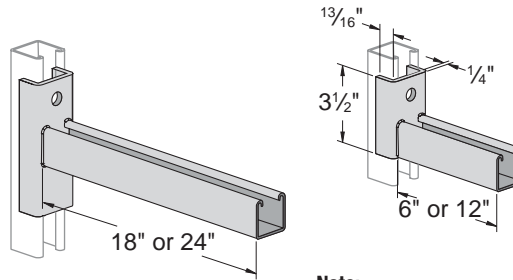

Size	Uniform Load*	Wt./100 pcs
6"	1,600	191
12"	800	292
18"	600	436
24"	450	536
*Mounted on 12 Ga. Channel		

Note:  
PS 661 T1 (Slot up) illustrated  
PS 661 T2 (Slot down) not shown

**PS 808 T1, PS 808 T2 - Interlocking Channel Bracket**

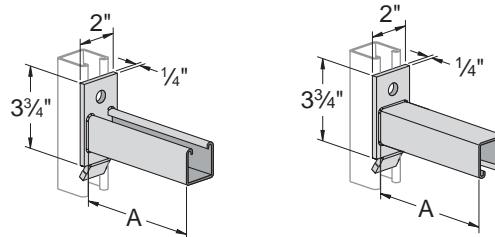

(PS 808 T1 - Slot Up)

(PS 808 T2 - Slot Down)

A Size	Uniform Load*	Wt./100 pcs
6"	1,200	161
12"	600	261
18"	400	361
24"	300	461
*Mounted on 12 Ga. Channel		

**PS 809 - Double Channel Bracket**

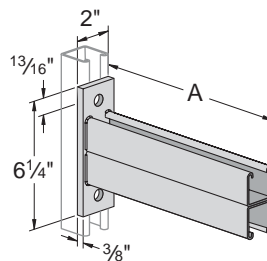

A Size	Uniform Load*	Wt./100 pcs
12"	2,000	502
18"	1,300	692
24"	1,000	882
30"	800	1,072
36"	650	1,262
*Mounted on 12 Ga. Channel		

**PS 732 - Shelf Bracket**

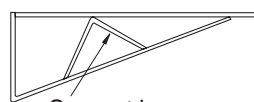
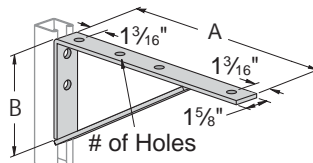

Support brace on 18" and 20" only.

Size	A	B	# of Holes	Uniform Load*	Wt./100 pcs
8"	8 1/2"	4"	2	800	168
10"	10 1/2"		3		202
12"	12 1/2"	6"	4	900	258
14"	14 1/2"		4		292
16"	16 1/2"		4		1,200
18"	18 1/2"		4	416	
20"	20 1/2"		4	461	
*Mounted on 12 ga. channel					

# BRACKETS

Finish: Painted Green or Electro-galvanized Order By: No., Size and Finish

## PS 3164 – Double Channel Bracket Support

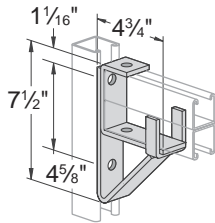

Use With: PS 200 2T3,  
PS 210 2T3

### Design Moment on Upright Channel:

- 16 ga. channel 6,500 in.-lbs.
- 14 ga. channel 9,100 in.-lbs.
- 12 ga. channel 13,000 in.-lbs.

Note:  
Moment is for fitting only.  
Channel may determine overall capacity.  
Weight/100 pcs: 273 lbs.

## PS 825 R or L – Single Pipe Axle Support

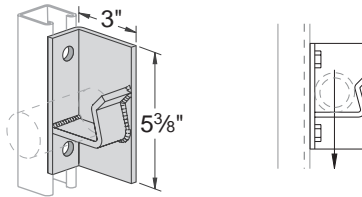

Right Hand Illustrated

Load Rating: 2,000 lbs.

Note:  
Specify R (Right) or L (Left) when ordering.

Weight/100 pcs.: 220 lbs.

## PS 826 – Double Pipe Axle Support

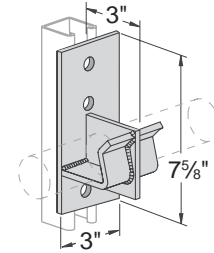

Load Rating: 4,000 lbs.

Weight/100 pcs.: 310 lbs.

## PS 838 R or L – Shelf Bracket

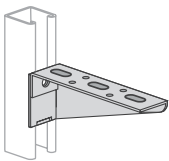

A Size	Stamped Ident. No.	B	Wt./100 pcs
6"	121892	1 <sup>15</sup> / <sub>16</sub> "	58
8"	121893	2 <sup>7</sup> / <sub>16</sub> "	83
10"	121894	2 <sup>15</sup> / <sub>16</sub> "	114
12"	121895	3 <sup>7</sup> / <sub>16</sub> "	49
14"	121896	3 <sup>15</sup> / <sub>16</sub> "	174
16"	121897	4 <sup>7</sup> / <sub>16</sub> "	225
18"	121898	4 <sup>15</sup> / <sub>16</sub> "	255
20"	121899	5 <sup>7</sup> / <sub>16</sub> "	295
22"	121900	5 <sup>15</sup> / <sub>16</sub> "	361
24"	121901	6 <sup>7</sup> / <sub>16</sub> "	396
26"	121902	6 <sup>15</sup> / <sub>16</sub> "	456
28"	121903	7 <sup>7</sup> / <sub>16</sub> "	479
30"	121904	7 <sup>15</sup> / <sub>16</sub> "	544

Stock Thickness: .105

Note: Specify R (Right) or L (Left) when ordering.  
Right Hand Illustrated

Uniform Load Rating:  
275 Lbs. when mounted on 12 ga. channel.

Only available in Painted Green or Electro-galvanized

## PS 3282 – Cable Tray Strut Bracket

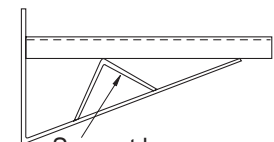
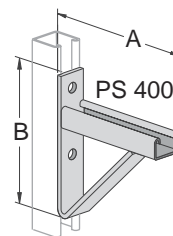

Support brace on 24", 30" and 36" only.

Note:  
PS 400 channel welded to 1/4" stock

Only available in Painted Green or Hot-dip-galvanized

A	B	Uniform Load*	Wt./100 pcs
12"	8 <sup>3</sup> / <sub>4</sub> "	1,900	388
18"		1,000	506
24"			763
30"	11 <sup>1</sup> / <sub>4</sub> "	900	1,012
36"		800	1,083

\*Mounted on 12 ga. channel.

## PS 2404 thru PS 2408 – Wall Ladder Bracket

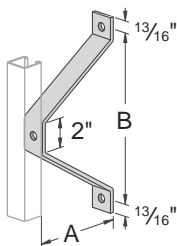

Only available in Hot-dip galvanized, Electro-galvanized or Painted Green

Part No.	A	B	Wt./100 pcs
PS 2404	2 <sup>3</sup> / <sub>8</sub> "	6"	113
PS 2405	4 <sup>3</sup> / <sub>8</sub> "	8"	164
PS 2406	6 <sup>3</sup> / <sub>8</sub> "	10"	216
PS 2407	8 <sup>3</sup> / <sub>8</sub> "	12"	267
PS 2408	10 <sup>3</sup> / <sub>8</sub> "	14"	318

## PS 2422 – 37 1/2 Degree Stair Tread Support

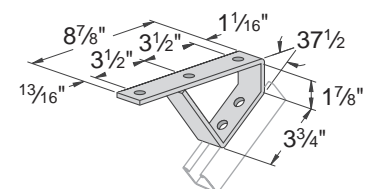

Weight/100 pcs: 213 lbs.

Only available in Painted Green, Hot-dip galvanized or Electro-galvanized

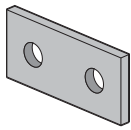

Metal Channel

Fasteners

Fittings

Pipe & Conduit Clamps

Electrical

Concrete Inserts

Solar Components

Unipier®

Jr. Channel

Power-Angle

Fiberglass

Tech. Data

## PS 2421 - 45° Degree Stair Tread Support

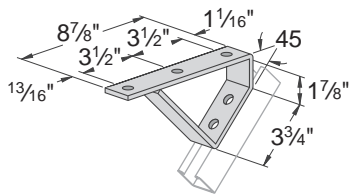

Weight/100 pcs: 220 lbs.

## PS 855 - Angular "I" Beam Clamp

1/2" - 13 X 1 1/2"  
Set Screw Included

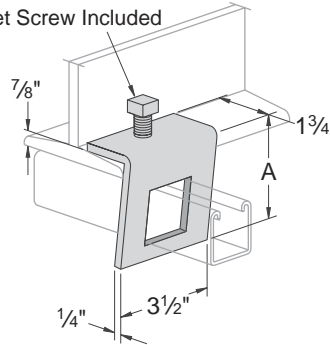

Part No.	Use With	A	Load Rating	Wt./100 pcs.
PS 855-1	PS 200, PS 210	3 1/2"	500	107
PS 855-2	PS 500			98

Use in pairs only

## PS 2657 - Double U Beam Clamp

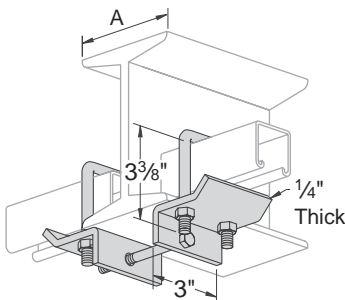

Specify 6" or 12" max. flange width  
(Example: PS 2657 T1-6")

**T1 Use with:**

PS 200, PS 210, PS 300,  
PS 400, PS 500, PS 520

**T2 Use with:**

PS 100, PS 150, PS 200 2T3

**T3 Use with:**

PS 150 2T3, PS 100 2T3

Part No.	"A" Beam Flange Width
PS 2657 T1-6	4" - 6"
PS 2657 T1-9	6" - 9"
PS 2657 T1-12	9" - 12"
PS 2657 T1-15	12" - 15"
PS 2657 T1-18	15" - 18"
PS 2657 T2-6	4" - 6"
PS 2657 T2-9	6" - 9"
PS 2657 T2-12	9" - 12"
PS 2657 T2-15	12" - 15"
PS 2657 T2-18	15" - 18"
PS 2657 T3-6	4" - 6"
PS 2657 T3-9	6" - 9"
PS 2657 T3-12	9" - 12"
PS 2657 T3-15	12" - 15"
PS 2657 T3-18	15" - 18"

Weight/100 pcs: 280 lbs.

## PS 2656 - U Bolt Beam Clamp With Hook

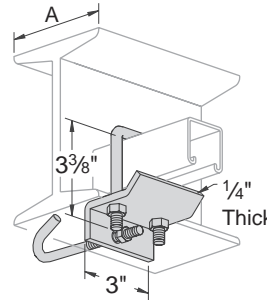

Specify 6" or 12" max. flange width  
(Example: PS 2656 T1-6")

**T1 Use with:**

PS 200, PS 210, PS 300,  
PS 400, PS 500, PS 520

**T2 Use with:**

PS 100, PS 150, PS 200 2T3

**T3 Use with:**

PS 150 2T3, PS 100 2T3

Part No.	"A" Beam Flange Width
PS 2656 T1-6	4" - 6"
PS 2656 T1-9	6" - 9"
PS 2656 T1-12	9" - 12"
PS 2656 T1-15	12" - 15"
PS 2656 T1-18	15" - 18"
PS 2656 T2-6	4" - 6"
PS 2656 T2-9	6" - 9"
PS 2656 T2-12	9" - 12"
PS 2656 T2-15	12" - 15"
PS 2656 T2-18	15" - 18"
PS 2656 T3-6	4" - 6"
PS 2656 T3-9	6" - 9"
PS 2656 T3-12	9" - 12"
PS 2656 T3-15	12" - 15"
PS 2656 T3-18	15" - 18"

Weight/100 pcs: 143 lbs.

## PS 685 - Beam Clamp

1/2" - 13 X 1 1/2"  
Set Screw Included

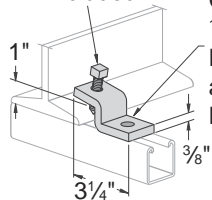

Clamp Requires  
1/2" x 1 5/16"  
Hex Head Cap Screw  
and 1/2" Channel  
Nut Not Included.

**Stock Thickness:** 3/8"  
**Load Rating:** 450 lbs.

Use in pairs only

Weight/100 pcs: 63 lbs.

## PS 2651 - Beam Clamp

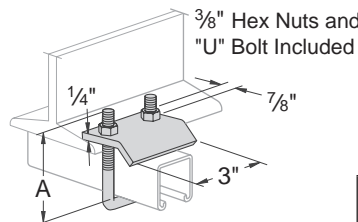

Part No.	Use With	A	Load Rating	Wt./100 pcs.
PS 2651 T1	PS 200, PS 210 PS 300, PS 400 PS 500, PS 520	3 3/8"	1,000	83
PS 2651 T2	PS 100, PS 150 PS 200 2T3	5"		92
PS 2651 T3	PS 150 2T3 PS 100 2T3	8 1/4"		112

Use in pairs only



# BEAM CLAMPS

Finish: Painted Green, or Electro-galvanized **Order By:** No. and Finish **Note:** Use in pairs or with other support

## PS 686 - Beam Clamp

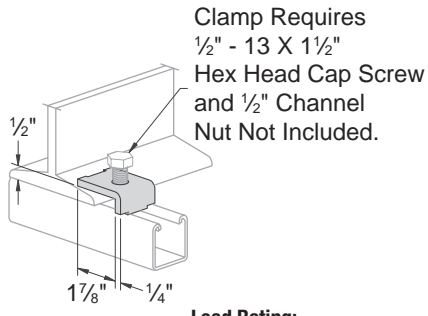

**Clamp Requires**  
1/2" - 13 X 1 1/2"  
Hex Head Cap Screw  
and 1/2" Channel  
Nut Not Included.

**Load Rating:**  
600 lbs. with 12 ga. channel  
500 lbs. with 14 ga. channel

Use in pairs only

Weight/100 pcs: 26 lbs.

## PS 2653 - Purlin Clamp

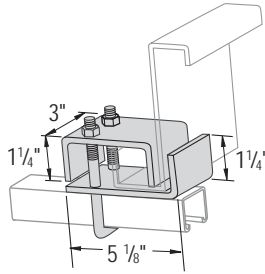

Part No.	Use With	Load Rating	Wt./100 pcs.
PS 2653 T1	PS 200, PS 210, PS 300	1,200	175
PS 2653 T2	PS 100, PS 150, PS 200 2T3		179
PS 2653 T3	PS 100 2T3		179

## PS 684 - "I" Beam Clamp

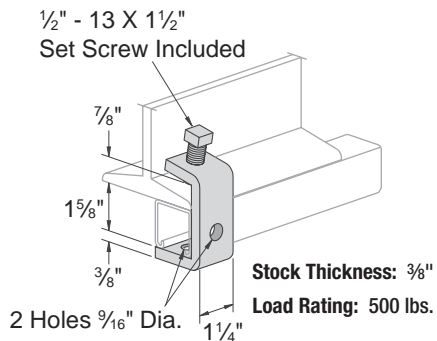

1/2" - 13 X 1 1/2"  
Set Screw Included

**Stock Thickness:** 3/8"  
**Load Rating:** 500 lbs.

2 Holes 9/16" Dia.

Weight/100 pcs: 94 lbs.

## PS 907, PS 998 - "I" Beam Clamp

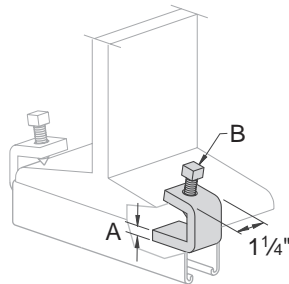

Part No.	Stock Thickness	Set Screw	Load Rating lbs.	Wt./100 pcs.
PS 907	1/4"	3/8"	450	26
PS 998	3/8"	1/2"	1,000	64

Load rating is based on 2 clamps  
Use in pairs only

Maximum flange thickness is 1"

## PS 916 - "I" Beam Clamp

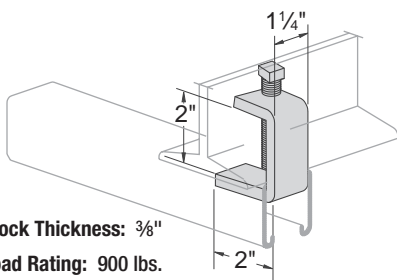

**Stock Thickness:** 3/8"  
**Load Rating:** 900 lbs.

Design loads are per pair of clamps

Weight/100 pcs: 72 lbs.

## PS 736 - Hook Rod Assembly

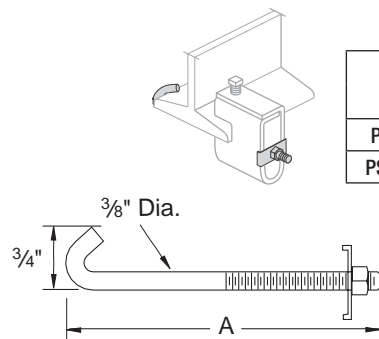

Part No.	Flange Width		A Size	Wt./100 pcs
	Max	Min		
PS 736 J6	7"	3"	8 5/8"	24
PS 736 J10	11"	7"	12 5/8"	33

## PS 2624 - Wood Beam Hanger

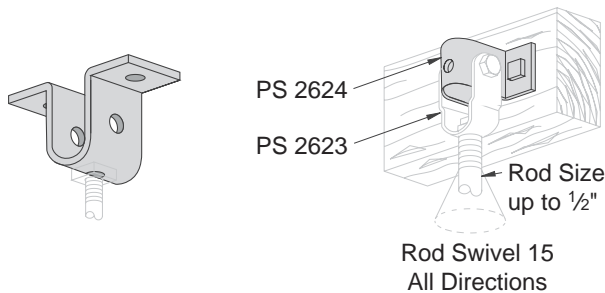

Weight/100 pcs: 22 lbs.

## PS 2622 - Beam Clamp

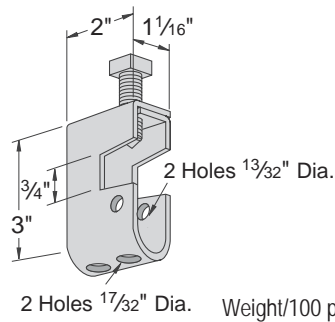

Assembly including PS 736 also available.

Order PS 2622/J6 or PS 2622/J10

**Load Rating:** 300 lbs.

**Note:**  
Adaptable for 1/4", 3/8" & 1/2" rod with PS 3201.

Weight/100 pcs: 41 lbs.

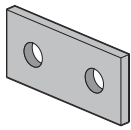

**Finish:** Painted Green, or Electro-galvanized **Order By:** No. and Finish  
**Note:** Use in pairs or with other support

## PS 85 - Rod or Insulator Support

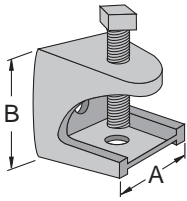

Rod Size	A	B	Load Ratings	Wt./100 pcs
1/4"	1 1/8"	1 1/4"	150	23
3/8"	2"	2"	350	95
1/2"	2 5/8"	2 1/4"	400	195

**Flange Thickness:** 7/8" Maximum  
**Material:** Malleable Iron

## PS 2626 - Beam Clamp

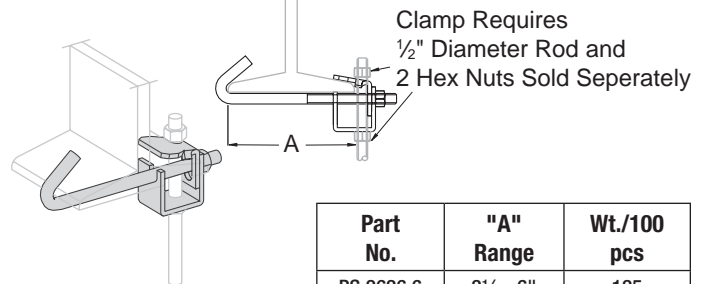

Part No.	"A" Range	Wt./100 pcs
PS 2626 6	2 1/2" - 6"	125
PS 2626 9	5 1/2" - 9"	140
PS 2626 12	8 1/2" - 12"	171

**Finish:** Plain, painted green or electro-galvanized  
**Load Rating:** 500 lbs.

## PS 2623 - Swivel Adaptor

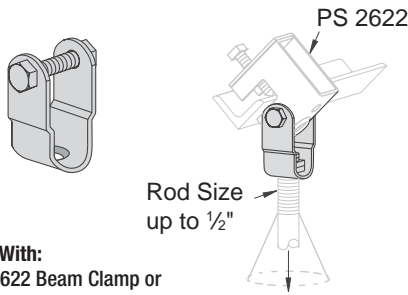

**Use With:**  
PS 2622 Beam Clamp or  
PS 2624 Wood Beam Hanger  
**Load Rating:** 300 lbs.

Rod Swivel 15  
All Directions

## PS 871 - Safety Anchor Strap

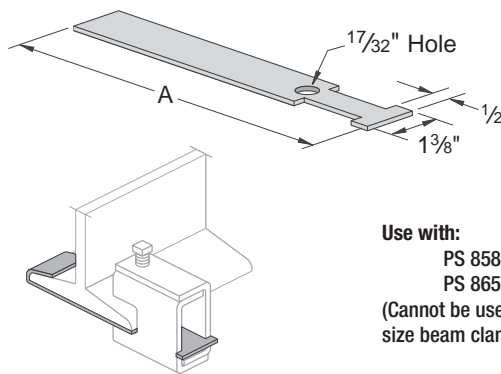

"A" Length	Wt./100 pcs
9"	33
12"	45
15"	57

**Use with:**  
PS 858,  
PS 865  
(Cannot be used with 5/8" rod size beam clamps and larger)

## PS 135X - Light Duty Beam Clamp

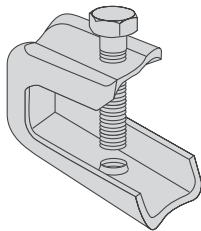

**Material:** Steel  
**Use With:** 1/4" rod  
**Load Rating:** 75 lbs.

Weight/100 pcs: 14 lbs.

## PS 858 - Heavy Duty Beam Clamp

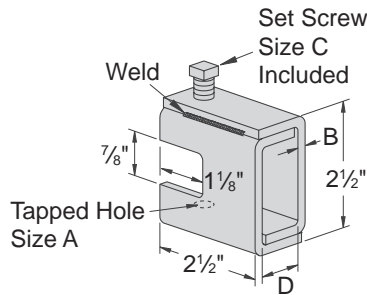

Part No.	"A" Rod Size	B	C	D	Load Ratings lbs.	Wt./100 pcs
PS 858 1/4	1/4" - 20	1/8"	3/8" x 1 1/2"	7/8"	650	67
PS 858 5/16	5/16" - 18	3/16"	1/2" x 1 1/2"	15/16"	1,100	100
PS 858 3/8	3/8" - 16	1/4"	5/8" x 1 1/2"	1 1/4"	1,600	130
PS 858 1/2	1/2" - 13	3/8"	7/8" x 1 1/2"	1 3/4"	2,400	160
PS 858 5/8	5/8" - 11	1/2"	1" x 1 1/2"	1 7/8"	2,400	160
PS 858 3/4	3/4" - 10	5/8"	1 1/4" x 1 1/2"	2"	2,400	160

**Weld is not continuous it is either 1 1/4" - 1 3/4" long or 2 spot welds. All welds are on the top and bottom.**

For beams under 7/8" thick flange.

## PS 3201 - Swivel Nut

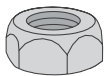

**Use With:**  
PS 2622 Beam Clamp

Rod Size	Wt./100 pcs
1/4"	4
3/8"	4
1/2"	3

Weight/100 pcs: 31 lbs.

## PS 865 - Wide Throat Heavy Duty Beam Clamp

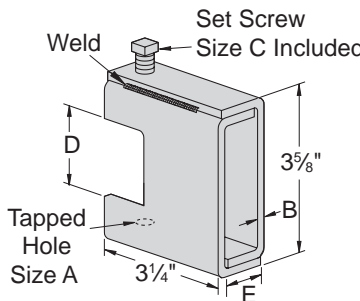

Part No.	Rod Size	B	C	D	E	Load Ratings lbs.	Wt./100 pcs
PS 865 3/8	3/8"	3/16"	1/2"	1 1/4"	29/32"	1,100	151
PS 865 1/2	1/2"	1/4"	3/4"	1 1/2"	1 1/4"	1,600	195
PS 865 5/8	5/8"	5/16"	5/8"	1 3/4"	1 1/2"	2,400	225

For beams between 3/4" (19) to 1 1/8" (41) thick flanges.

**Weld is not continuous it is either 1 1/4" - 1 3/4" long or 2 spot welds. All welds are on the top and bottom.**

Metal Channel  
Fasteners  
Fittings  
Pipe & Conduit Clamps  
Electrical  
Concrete Inserts  
Solar Components  
Unipier®  
Jr. Channel  
Power-Angle  
Fiberglass  
Tech. Data

# BEAM CLAMPS

Finish: Painted Green, or Electro-galvanized **Order By:** No. and Finish **Note:** Use in pairs or with other support

## PS 95 - "C" Clamp

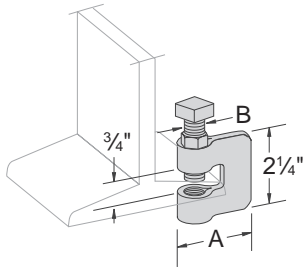

Rod Size	A	B	Load Rating	Wt./100 pcs
3/8"	2 <sup>5</sup> / <sub>16</sub> "	3/8"	330	35
1/2"	2 <sup>1</sup> / <sub>4</sub> "	1/2"	380	41
5/8"	2 <sup>3</sup> / <sub>8</sub> "	5/8"	450	67
3/4"	2 <sup>1</sup> / <sub>4</sub> "	1/2"	500	72

Material: Steel

## PS 86 - "C" Clamp

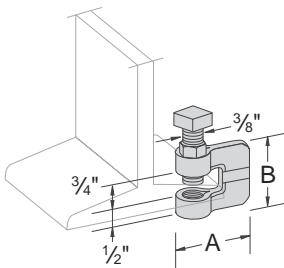

Rod Size	A	B	Load Rating	Wt./100 pcs
3/8"	1 <sup>1</sup> / <sub>16</sub> "	1 <sup>3</sup> / <sub>4</sub> "	400	38
1/2"	1 <sup>23</sup> / <sub>32</sub> "			52
5/8"	1 <sup>15</sup> / <sub>16</sub> "	2"	600	68
3/4"	2 <sup>1</sup> / <sub>32</sub> "			128

Material: Malleable Iron, Steel Set Screw

## PS 2654 & PS 2654A - Column Attachment

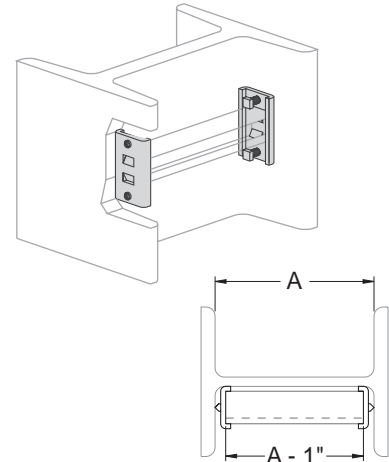

PS 2654 Use with PS 200

PS 2654A Use with PS 500

Slip Rating: 800 lbs.

Note: Column attachment can only be used in pairs.

Weight/100 pcs: 41 lbs.

## PS 93 - Universal "C" Clamp

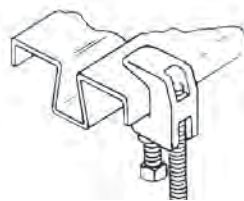
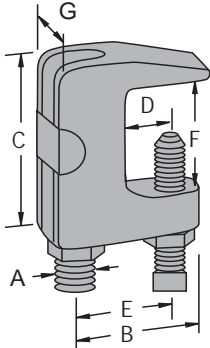

At least one full thread must be exposed

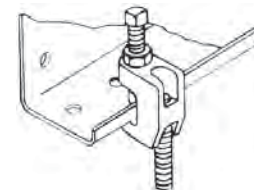

Material: Malleable Iron, Steel Set Screw

Part No.	Rod Size A	DIMENSIONS (Inches)				Max. Pipe Size	Max. Load (Lbs.)	Wt/100 pcs
		B	C	D	E			
PS 93 3/8	3/8	1 <sup>5</sup> / <sub>8</sub>	2	3/4	7/8	2	400	28
PS 93 1/2	1/2	1 <sup>5</sup> / <sub>8</sub>	2	3/4	7/8	3 <sup>1</sup> / <sub>2</sub>	500	34

• Maximum temperature of 450° F

## PS 94 - Wide Throat Top Beam "C" Clamp

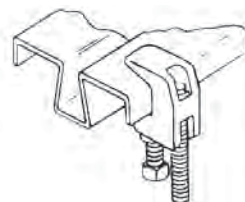
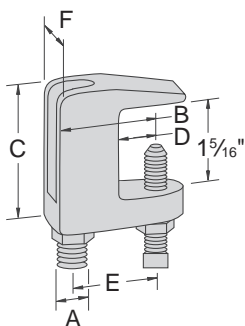

At least one full thread must be exposed

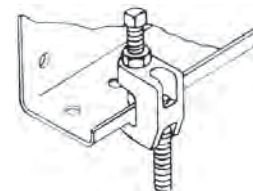

Material: Malleable Iron, Steel Set Screw

Part No.	Rod Size A	DIMENSIONS (Inches)					Max Pipe Size	Max. Load (Lbs.)	Wt/100 pcs
		B	C	D	E	F			
PS 94 5/8	5/8	1 <sup>3</sup> / <sub>4</sub>	2 <sup>1</sup> / <sub>4</sub>	3/4	1 <sup>1</sup> / <sub>4</sub>	1	5	600	66
PS 94 3/4	3/4	1 <sup>7</sup> / <sub>8</sub>	2 <sup>3</sup> / <sub>8</sub>	3/4	1 <sup>3</sup> / <sub>8</sub>	1 <sup>1</sup> / <sub>4</sub>	8	800	83

• Maximum temperature of 450° F

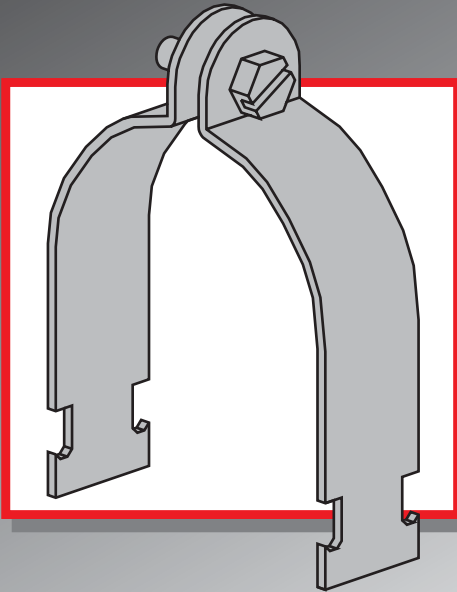

## PIPE & CONDUIT CLAMPS

*Power-Strut pipe, conduit and O.D. tubing clamps are formed in punch press dies in a wide selection of sizes to meet every requirement.*

### **MATERIAL:**

Power-Strut pipe, conduit and O.D. tubing clamps are made on punch press dies from hot rolled, pickled and oiled steel which conforms to the ASTM A1008, A575, A576, A635, A1011 SS GR 33, A1011 HSLAS GR 45, or A36 standards. The fitting steel also meets or exceeds the physical properties of ASTM A1011 GR 33. Select sizes of O.D. tubing clamps are available in stainless steel or aluminum.

### **STANDARD FINISH:**

All steel clamps are electro-galvanized. Clamps are also available in hot-dipped galvanized, Power-Green, and Power-Gold

### **ORDERING INFORMATION:**

When ordering, add the length or size and finish to the part number.  
See pages 8-9 for finish abbreviations and an example.

### **RECOMMENDED BOLT TORQUE:**

Bolt Size	1/4"-20	5/16"-18	3/8"-16	1/2"-13	5/8"-11	3/4"-10
Rec. Torque Ft-Lbs	6	11	19	50	100	125
Max. Torque Ft-Lbs	7	15	25	70	125	135

# PIPE & CONDUIT CLAMPS

Order By: No., and Finish

## PS 1000 - EMT Conduit Clamp

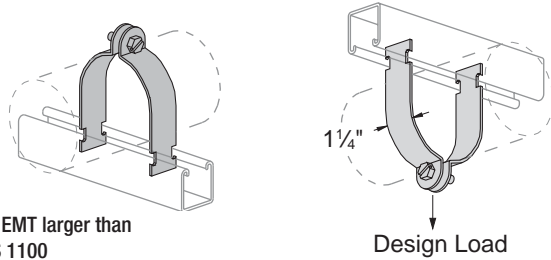

Note: For EMT larger than 2" use PS 1100

EMT Size	Stock Thickness	Hanging Load Rating/lbs.	Wt./100 pcs
1/2"	.060	400	11
3/4"			12
1"	.075	600	15
1 1/4"			18
1 1/2"	.105	800	29
2"			33

## PS 1300 - Universal Clamp for EMT, IMC & GRC

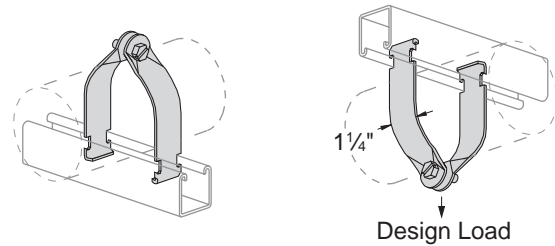

Nominal Size	Fits O.D.	Stock Thickness	Hanging Load Rating/lbs.	Wt./100 pcs
1/2"	0.706-0.840	.060	250	10
3/4"	0.922-1.050	.060	400	11
1"	1.163-1.315			12
1 1/4"	1.510-1.660	.075	400	18
1 1/2"	1.740-1.900	.075	500	20
2"	2.197-2.375			22

## PS 1100, PS 1116, PS 1117 - Standard Pipe Clamp (GRC, IMC and SCH 40/SCH 80 steel pipe)

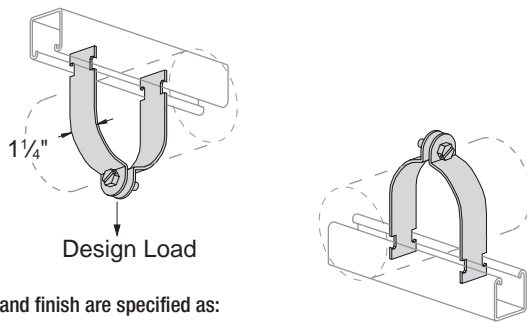

Material and finish are specified as:

- 1100 AL Alum. clamp, EG fasteners
- 1100 HG Clamp, Stainless Steel fasteners
- 1116 Alum. clamp and fasteners
- 1117 Alum. clamp, Stainless Steel fasteners
- 1100SS Stainless Steel clamp and fasteners

Pipe Size	Stock Thickness	Hanging Load Rating/lbs.	Wt./100 pcs
3/8"	.060	400	10
1/2"			11
3/4"	.075	600	15
1"			17
1 1/4"			19
1 1/2"	.105	800	29
2"			34
2 1/2"			40
3"			47
3 1/2"	.125	1,000	62
4"			67
5"			80
6"	.135	1,000	102
8"			130
10"			143
12"			174

## PS 67 - "J" Pipe or Conduit Hanger

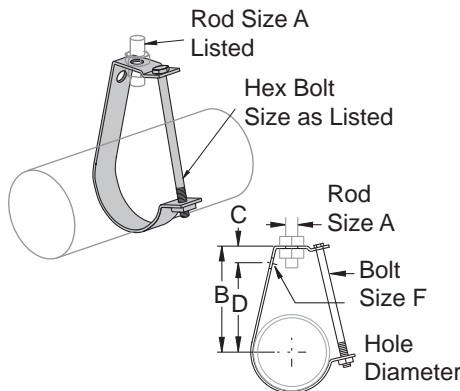

**Notes:**  
 Hanger Rod Suspended  
 Plastic Coated hanger is available ("N" Suffix).  
 Please contact factory for additional information.  
 Maximum operating temperature is 300°F  
 Minimum safety factor of five (5) on ultimate load.

Conduit Size	A Rod Size	B	C	D	E	F	Load Rating/lbs.	Wt./100 pcs	
1/2"	3/8	2 5/8	1	2	1 3/2	1/4 x 2 1/4	400	20	
3/4"		2 7/8		2 1/4				21	
1"		3		2 3/8				24	
1 1/4"		3 1/4		2 1/2				27	
1 1/2"	1/2	3 1/2	1 1/8	2 5/8	9/16	1/4 x 3	800	29	
2"		3 3/4		2 5/8				33	
2 1/2"		4 3/8		3 3/8				3 3/8	71
3"		4 7/8							3/8 x 4 1/2
3 1/2"	5/8	5 1/8	1 1/8	4	9/16	3/8 x 5	1,000	85	
4"		6 1/8		4 1/4				178	
5"		6 3/4		5 1/8				199	
6"		7 3/4		5 3/4				231	
8"	7/8	9 1/4	1 1/4	8	9/16	3/8 x 8 1/2	1,200	449	
							3/8 x 10		

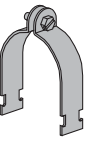

## PS 1200 - O.D. Tubing Clamp

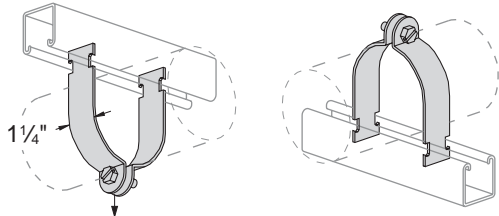

Design Load

Please contact factory for sizes & finishes not shown.

**Note:** Additional Available Finishes  
SS - Stainless Steel  
CC - Copper Coated

O.D. Size	Stock Thickness	Hanging Load Rating/lbs.	Wt./100 pcs
1/4"	.060	400	8
3/8"			8
1/2"			9
5/8"			10
3/4"			11
7/8"			12
1"	.075	600	14
1 1/8"			15
1 1/4"			16
1 3/8"			17
1 1/2"			18
1 5/8"			19
1 3/4"	.105	800	29
1 7/8"			28
2"			31
2 1/8"			32
2 1/4"			33
2 3/8"			34
2 1/2"			35
2 5/8"			37
2 3/4"			38
2 7/8"			40
3"			41

O.D. Size	Stock Thickness	Hanging Load Rating/lbs.	Wt./100 pcs
3 1/8"	.105	800	43
3 1/4"			45
3 3/8"			46
3 1/2"			47
3 5/8"			56
3 3/4"			58
3 7/8"	.125	1,000	60
4"			62
4 1/8"			62
4 1/4"			64
4 3/8"			66
4 1/2"			67
4 5/8"			70
4 3/4"			72
4 7/8"			73
5"			74
5 1/8"			76
5 1/4"			77
5 3/8"	78		
5 1/2"	79		
5 5/8"	.135	1,000	88
5 3/4"			90
5 7/8"			92

O.D. Size	Stock Thickness	Hanging Load Rating/lbs.	Wt./100 pcs
6"	.135	1,000	94
6 1/8"			96
6 1/4"			98
6 3/8"			99
6 1/2"			100
6 5/8"			102
6 3/4"			104
6 7/8"			106
7"			108
7 1/8"			110
7 1/4"			112
7 3/8"			114
7 1/2"			116
7 5/8"			117
7 3/4"			119
7 7/8"			121
8"			123
8 1/8"			125
8 1/4"	126		
8 3/8"	128		
8 1/2"	129		
8 5/8"	130		

## PS 137 - Long Tangent "U" Bolt

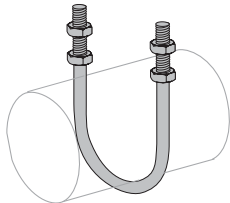

Size	Wt./100 pcs
1/2"	21
3/4"	28
1"	29
1 1/4"	31
1 1/2"	33
2"	36
2 1/2"	78
3"	88
3 1/2"	94
4"	102

## PS 69 - E-Z Grip Hanger

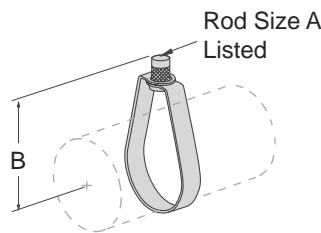

Size	A Rod Size	B	Load Rating Lbs/650	Wt./100 pcs
1/2"	3/8"	2 1/4"	300	9
3/4"		2 5/16"		9
1"		2 7/16"		10
1 1/4"		2 5/8"		10
1 1/2"		2 3/4"		10
2"		3 1/4"		11
2 1/2"	1/2"	4"	525	25
3"		4 3/8"		27
4"		4 11/16"		600
5"	1/2"	5 5/16"	1000	53
6"		6 7/16"		100
7"		8"		100

# PIPE & CONDUIT CLAMPS

Order By: No., and Finish

## PS 3138 – Parallel Run Pipe Clamp

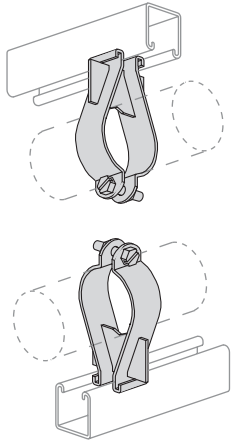

Pipe Size	Load Rating/lbs.	Wt./100 pcs
3/8"	300	27
1/2"		29
3/4"		30
1"	400	31
1 1/4"		38
1 1/2"	500	40
2"		47
2 1/2"		66
3"		78
3 1/2"		87
4"	90	

## PS 270 – Conduit Clamp

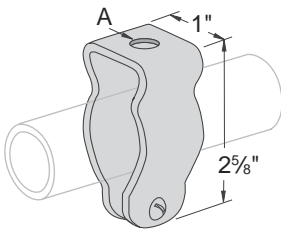

Size	A Diameter	Wt./100 pcs
3/8"	1/4"	6
1/2"		6
3/4"		8
1"		9
1 1/4"		11
1 1/2"		19
2"		27

## PS 1450 – One-Hole Clamp for O.D. Tubing

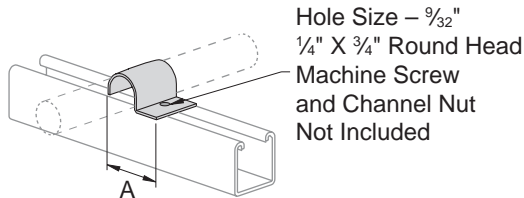

Hole Size – 3/32"  
1/4" X 3/4" Round Head  
Machine Screw  
and Channel Nut  
Not Included

O.D. Size	A	Thickness Gages	Wt./100 pcs
1/4"	1 3/16"	16	4
3/8"	1 5/16"		5
1/2"	1 7/16"		6
5/8"	1 5/8"	14	8
3/4"	1 3/4"		9
7/8"	1 7/8"		10
1"	2"		11

## PS 3126 – One-Piece Pipe Strap

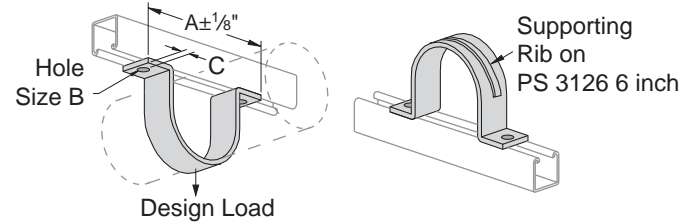

Pipe Size	A	B	C	Design Load/lbs.	Wt./100 pcs
1/2"	2 7/8"	9/32"	7/16"	500	23
3/4"	3 1/8"				26
1"	3 3/8"				31
1 1/4"	3 3/4"				35
1 1/2"	3 7/8"				39
2"	5 3/4"	7/16"	1 1/16"	1,000	94
2 1/2"	6 1/4"				114
3"	6 7/8"				133
3 1/2"	7 3/8"				152
4"	7 7/8"				176
5"	9"				198
6"	10"	225			

## PS 51 – Right Angle Pipe or Conduit Clamp

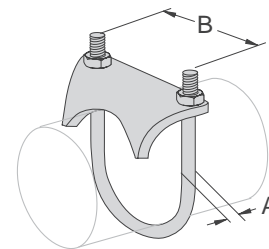

Material: Malleable Iron

Size	A Diameter	B	Wt./100 pcs
3/8"	5/16"	1 5/16"	25
1/2"		1 3/16"	41
3/4"		1 1/16"	42
1"		1 11/16"	47
1 1/4"		2"	54
1 1/2"	3/8"	2 5/16"	57
2"		2 3/16"	85
2 1/2"		3 3/8"	106
3"		4 1/8"	110
3 1/2"		4 5/8"	128
4"		5 1/8"	140

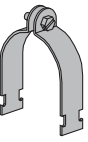

**PS TP-025 thru PS TP-100 - Cush-A-Grip®**

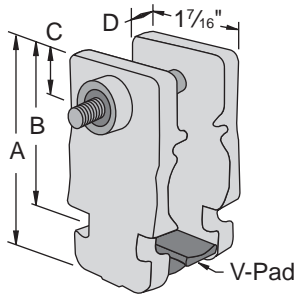

Part No.	Nominal Pipe Size	Dimensions (In.)				Hex Head Cap Screw & Lock Nut	Wt/100 pcs Lbs
		"A"	"B"	"C"	"D"		
PS TP-025	1/4	1 15/16	1 3/8	3/8	3/16	1/4-20 x 1 1/2"	4
PS TP-625	3/8	2 3/8	1 5/8	7/16	1/4	1/4-20 x 2"	6
PS TP-875	1/2	2 9/16	1 13/16		5/16		8
PS TP-100	3/4	2 1 1/16	1 15/16		5/16		8

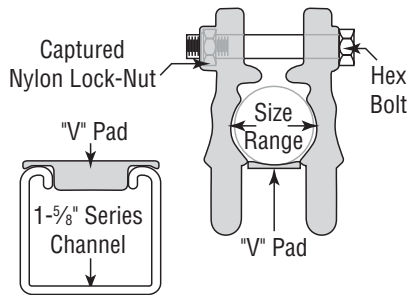

**Includes:** Cushion, V-pad, and Hardware.  
**Materials:** Cushion: Thermoplastic elastomer.  
**Hardware:** Stainless Steel with Captured Nylon Locknut  
**Temperature Rating:** -40°F to +275°F

**Tube Sizes**

Part No.	O.D. Tube Sizes			Diameters	PullOut Load/Lbs	Slip Load/Lbs
PS TP-025	1/4	3/8	1/2	0.25 - 0.54	500	40
PS TP-625	5/8	3/4	7/8	0.62 - 0.87		
PS TP-875	7/8	1	1 1/8	0.87 - 1.12		
PS TP-100	1	1 1/8	1 1/4	1.00 - 1.31		

**Pipe Sizes**

Part No.	Nominal Pipe Sizes		Diameters	PullOut Load/Lbs	Slip Load/Lbs
PS TP-025	1/4		0.25 - 0.54	500	40
PS TP-625	3/8	1/2	0.62 - 0.87		
PS TP-875	3/4		0.87 - 1.12		
PS TP-100	3/4	1	1.00 - 1.31		

**PS CT-3/8 thru PS CT1-4-1/8 - Cush-A-Therm™**

The only airtight, crush-resistant insulation clamp on the market.

- Maintains thermal barrier protection
- Prevents condensation
- Properly supports pipe and tube
- Absorbs vibration

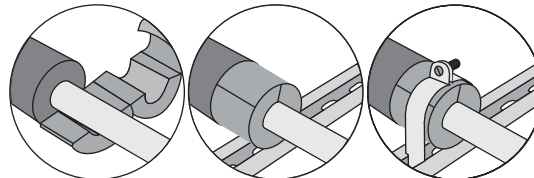

1. Insulation slides over pipes
2. Pipe hanger inserts are put in place and glued to insulation.
3. Joints are wrapped and sealed with ProTape.

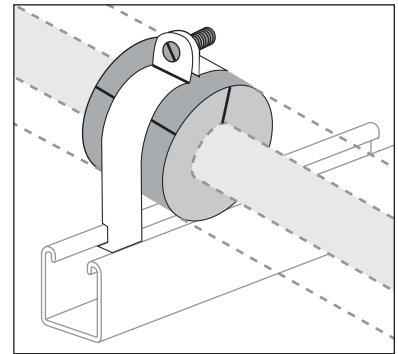

**Nominal 3/4" Wall**

Part No.	Hole Size	Copper Nom. I.D.	O.D.	IPS	O.D.	Length
PS CT-3/8	3/8 ID	1/4	3/8	-	1.81	2.17
PS CT-1/2	1/2 ID	3/8	1/2	1/4	1.89	
PS CT-5/8	5/8 ID	1/2	5/8	3/8	2.05	
PS CT-3/4	3/4 ID	5/8	3/4	-	2.22	
PS CT-7/8	7/8 ID	3/4	7/8	1/2	2.44	
PS CT-1-1/8	1 1/8 ID	1	1 1/8	3/4	2.76	2.56
PS CT-1-3/8	1 3/8 ID	1 1/4	1 3/8	1	3.19	
PS CT-1-5/8	1 5/8 ID	1 1/2	1 5/8	1 1/4	3.35	
PS CT-2-1/8	2 1/8 ID	2	2 1/8	-	3.86	
PS CT-2-1/4	2 1/4 ID	2 1/4	2 3/8	2	4.29	
PS CT-2-5/8	2 5/8 ID	2 1/2	2 5/8	-	4.87	2.96
PS CT-3-1/8	3 1/8 ID	3	3 1/8	-	5.00	
PS CT-3-5/8	3 5/8 ID	3 1/2	3 5/8	-	5.94	
PS CT-4-1/8	4 1/8 ID	4	4 1/8	3 1/2	6.14	3.94

**Nominal 1" Wall**

Part No.	Hole Size	Copper Nom. I.D.	O.D.	IPS	O.D.	Length
PS CT1-5/8	5/8 ID	1/2	5/8	3/8	2.54	2.17
PS CT1-3/4	3/4 ID	5/8	3/4	-	2.82	
PS CT1-7/8	7/8 ID	3/4	7/8	1/2	2.82	
PS CT1-1-1/8	1 1/8 ID	1	1 1/8	3/4	3.06	
PS CT1-1-3/8	1 3/8 ID	1 1/4	1 3/8	1	3.33	2.56
PS CT1-1-5/8	1 5/8 ID	1 1/2	1 5/8	1 1/4	3.65	
PS CT1-2-1/8	2 1/8 ID	2	2 1/8	-	4.16	
PS CT1-2-3/8	2 3/8 ID	2 1/4	2 3/8	2	3.92	
PS CT1-2-5/8	2 5/8 ID	2 1/2	2 5/8	-	4.87	2.96
PS CT1-3-1/8	3 1/8 ID	3	3 1/8	-	5.14	3.35
PS CT1-3-5/8	3 5/8 ID	3 1/2	3 5/8	-	6.48	3.94
PS CT1-4-1/8	4 1/8 ID	4	4 1/8	3 1/2	6.48	



# PIPE & CONDUIT CLAMPS

Order By: No., and Finish

**PS 004T – PS 106N – Cush-a-Clamp® Assembly Pipe & Tube Series**

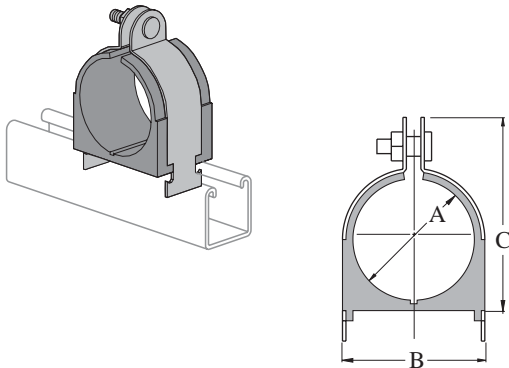

**Clamp:** Electro-galvanized or stainless steel

**Cushion:** Thermoplastic elastomer resistant to the effects of most oils, chemicals and industrial cleaning compounds in temperatures from -50°F to 275°F.  
UV Resistant

**Includes:** Cushion, Clamp and Hardware

**Controlled Squeeze:** Parts with the letter "T" have a Controlled Squeeze shoulder Bolt. Available on tube sizes 1/4" thru 1 3/8"

Pipe Series					
Part No.	Pipe Size (Nominal)	Dimensions			Wt./100 pcs
		A	B	C	
PS 009N	1/4"	0.54	0.98	1.34	13
PS 011N	3/8"	0.67	1.13	1.54	14
PS 014N	1/2"	0.84	1.29	1.82	15
PS 017N	3/4"	1.05	1.50	2.08	17
PS 021N	1"	1.31	1.76	2.34	19
PS 027N	1 1/4"	1.66	2.17	2.73	35
PS 030N	1 1/2"	1.90	2.35	2.86	41
PS 038N	2"	2.37	2.82	3.67	49
PS 046N	2 1/2"	2.87	3.32	4.17	57
PS 056N	3"	3.50	3.95	4.79	55
PS 064N	3 1/2"	4.00	4.45	5.42	88
PS 072N	4"	4.50	4.95	5.92	110
PS 089N	5"	5.56	6.01	6.92	130
PS 106N	6"	6.62	7.07	8.23	140

Tube Series						
Part No.	Copper & Steel Tube O. D. Size	Copper Water Pipe (Nominal)	Dimensions			Wt./100 pcs
			A	B	C	
PS 004T	1/4"		0.25	0.62	0.98	10
PS 006T	3/8"	1/4"	0.37	0.82	1.13	11
PS 008T	1/2"	3/8"	0.50	0.94	1.34	13
PS 010T	5/8"	1/2"	0.62	1.06	1.54	14
PS 012T	3/4"	5/8"	0.75	1.2	1.68	14
PS 014T	7/8"	3/4"	0.87	1.31	1.82	15
PS 016T	1"		1.00	1.44	1.95	17
PS 018T	1 1/8"	1"	1.12	1.57	2.08	18
PS 020T	1 1/4"		1.25	1.70	2.21	18
PS 022T	1 3/8"	1 1/4"	1.37	1.82	2.34	20
PS 024N	1 1/2"		1.50	1.95	2.47	33
PS 026N	1 5/8"	1 1/2"	1.62	2.07	2.60	35
PS 028N	1 3/4"		1.75	2.20	2.73	37
PS 030N	1 7/8"		1.87	2.32	2.86	39
PS 032N	2"		2.00	2.45	3.04	41
PS 034N	2 1/8"		2.12	2.57	3.23	46
PS 038N	2 3/8"		2.37	2.82	3.67	47
PS 040N	2 1/2"		2.50	2.94	3.79	49
PS 042N	2 5/8"		2.62	3.07	3.92	51
PS 046N	2 7/8"		2.87	3.32	4.17	55
PS 048N	3"		3.00	3.57	4.42	57
PS 050N	3 1/8"		3.12	3.57	4.42	60
PS 056N	3 1/2"		3.50	3.95	4.79	55
PS 058N	3 5/8"		3.62	4.2	5.11	70
PS 064N	4"		4.00	4.45	5.42	88
PS 066N	4 1/8"		4.12	4.57	5.54	94
PS 072N	4 1/2"		4.50	4.95	5.92	110
PS 082N	5 1/8"		5.12	5.57	6.54	125
PS 098N	6 1/8"		6.12	6.57	7.54	130

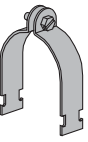

Order By: No., and Finish

## PS 3792 – Power-Wrap™

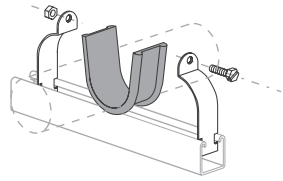

**Material:** EPDM  
**Stock Thickness:** 1/8"  
**Stock Length:** 25 ft./box  
**Service Temp:** -70° to 350° F

Weight/100 boxes: 253 lbs.

## PS 52E – Parallel Pipe and Conduit Clamp

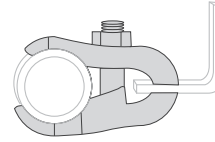

**Material:** Malleable Iron

Size	Wt./100 pcs
1/2"	59
3/4"	64
1"	70
1 1/4"	72
1 1/2"	93
2"	128
2 1/2"	135
3"	155
3 1/2"	190
4"	205

## PS 004M – PS 038M – Cush-a-Clamp® Assembly Omega Series

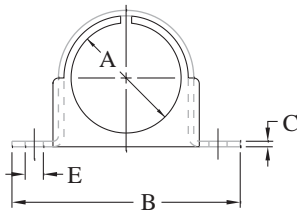
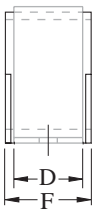
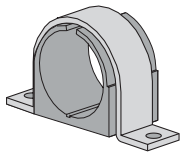

**Includes:** clamp and cushion.  
**Materials**  
**Clamp:** ZD or Stainless Steel  
**Cushion:** Thermoplastic elastomer

Part No.	Copper Tubing O.D. Size	Water Pipe (Nominal)	Pipe Size (Nominal)	Dimensions						Wt./100 pcs		
				A	B	C	D	E	F			
PS 004M	1/4"	–	–	0.25	1.81	0.06	0.62	0.20	0.78	3.4		
PS 006M	3/8"	1/4	–	0.37	1.90			0.20	0.81	4.0		
PS 008M	1/2"	3/8	1/4"	0.50	2.20		0.75	0.26	0.98	5.5		
PS 010M	5/8"	1/2	3/8"	0.62	2.32					6.0		
PS 012M	3/4"	5/8	–	0.75	2.41					6.5		
PS 014M	7/8"	3/4	1/2"	0.87	2.56					7.1		
PS 016M	1"	–	–	1.00	2.68					7.8		
PS 018M20	–	–	3/4"	1.05	2.68					8.1		
PS 018M21	1 1/8"	1	–	1.12	2.82					8.4		
PS 020M	1 1/4"	–	–	1.25	3.00					0.08	1.25	0.26
PS 021M	–	–	1"	1.31	3.12	20						
PS 022M	1 3/8"	1 1/4	–	1.37	3.12	19						
PS 024M	1 1/2"	–	–	1.50	3.65	20						
PS 026M	1 5/8"	1 1/2	–	1.62	3.77	23						
PS 027M	–	–	1 1/4"	1.66	3.90	0.10	1.25	0.33	32			
PS 028M	1 3/4"	–	–	1.75	3.90				32			
PS 030M	1 7/8"	–	1 1/2"	1.87	4.02				34			
PS 032M	2"	–	–	2.00	4.15				36			
PS 034M	2 1/8"	–	–	2.12	4.40				41			
PS 038M	–	–	2"	2.37	4.71				44			

**Note:** Cannot be used on slot side of metal framing channel.

Metal Channel  
Fasteners  
Fittings  
Pipe & Conduit Clamps  
Electrical  
Concrete Inserts  
Solar Components  
Unipier®  
Jr. Channel  
Power-Angle  
Fiberglass  
Tech. Data

# PIPE & CONDUIT CLAMPS

Order By: No., and Finish

**PS MU-1/4 thru PS MU-4 - Mustang Universal One-Piece Pipe, Conduit (GRC, EMT & IMC) and Tubing Clamps**

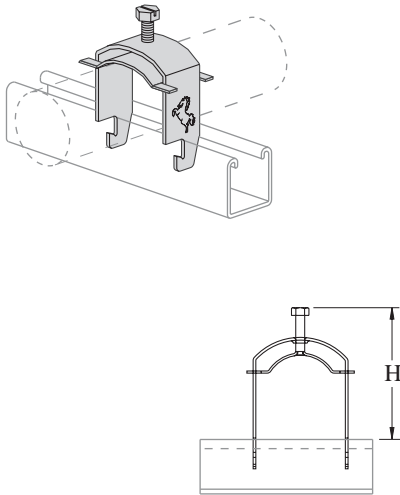

Part No.	Nominal Trade Size	OD		Height Above Channel "H"	
		Min	Max	Min	Max.
PS MU-1/4	1/4"	0.250"	0.540"	1 3/4"	2"
PS MU-3/8	3/8"	0.500"	0.675"	1 7/8"	2 1/8"
PS MU-1/2	1/2"	0.625"	0.840"	2"	2 1/4"
PS MU-3/4	3/4"	0.875"	1.050"	2 1/4"	2 1/2"
PS MU-1	1"	1.125"	1.315"	2 1/2"	2 3/4"
PS MU-1-1/4	1 1/4"	1.375"	1.660"	2 3/4"	3 1/8"
PS MU-1-1/2	1 1/2"	1.625"	1.900"	3"	3 3/8"
PS MU-2	2"	2.000"	2.375"	3 1/2"	3 7/8"
PS MU-2-1/2	2 1/2"	2.500"	2.875"	4 1/4"	4 5/8"
PS MU-3	3"	3.000"	3.500"	4 7/8"	5 3/8"
PS MU-3-1/2	3 1/2"	3.625"	4.000"	5 5/8"	5 7/8"
PS MU-4	4"	4.125"	4.500"	5 7/8"	6 3/8"

**Note:**  
Available in 14 ga. Electro-galvanized steel

**PS UB 1/2 - PS UB 10 - Cush-a-Clamp® Assembly U-Bolt Series**

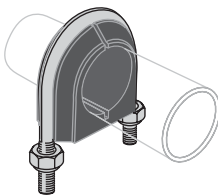

**Includes:** U-bolt, cushion, and hardware.  
**Materials:** U-Bolt: Electrogalvanized finish or Type 316 SS  
**Cushion:** Thermoplastic elastomer  
**Note:** Not intended for use with metal framing components due to the length of the thread.

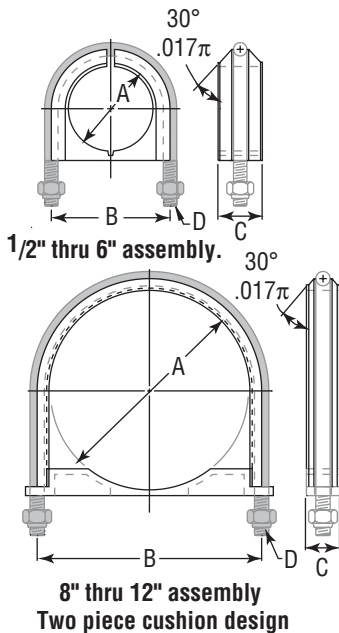

Part No.	Pipe Size	Dimensions				Wt./100 Pcs
		A	B	C	D	
PS UB 1/2	1/2"	0.84	1.60	0.68	1/4-20 UNC-2B	9
PS UB 3/4	3/4"	1.05	1.80			10
PS UB 1	1"	1.31	2.05			12
PS UB 1-1/4	1 1/4"	1.66	2.55	1.24	3/8-16 UNC-2B	32
PS UB 1-1/2	1 1/2"	1.90	2.80			36
PS UB 2	2"	2.37	3.35			42
PS UB 2-1/2	2 1/2"	2.87	3.90	1.24	1/2-13 UNC-2B	72
PS UB 3	3"	3.50	4.55			84
PS UB 3-1/2	3 1/2"	4.00	5.05			93
PS UB 4	4"	4.50	5.50			102
PS UB 5	5"	5.56	6.56	1.44	5/8-11 UNC-2B	123
PS UB 6	6"	6.62	7.75			243
PS UB 8	8"	8.62	9.82			293
PS UB 10	10"	10.75	12.16			492

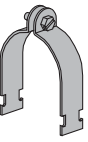

Metal Channel  
Fasteners  
Fittings  
Pipe & Conduit Clamps  
Electrical  
Concrete Inserts  
Solar Components  
Unipier®  
Jr. Channel  
Power-Angle  
Fiberglass  
Tech. Data

**PS 1901 - Two-Piece Pipe Roller**

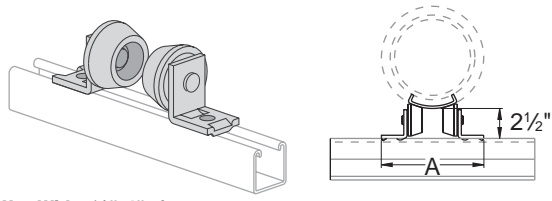

**Use With:** 1/2"-4" pipe  
**Load Rating:** 500 lbs.  
**Material:**  
 Bracket - steel;  
 Roller - cast iron (or aluminum)  
**Finish:** Green or galvanized;  
 Roller - plain  
 Weight/100 pair: 268 lbs.

Chart for Dimension A								
Pipe Size	No Insulation	Insulation Thickness						
		1"	1 1/2"	2"	2 1/2"	3"	4"	
1/2"	6 1/2"	6 1/2"	-	-	-	-	-	
3/4"			6 5/8"	6 7/8"				
1"			6 7/8"	7 1/8"	7 3/8"			
1 1/4"				7 1/2"	7 5/8"			
1 1/2"		6 5/8"	7 1/8"	7 3/8"	7 1/2"	8"		
2"			7"	7 1/2"	7 3/4"	7 7/8"		8 1/8"
2 1/2"				7 1/4"	7 5/8"	7 3/4"		8 1/4"
3"		7 1/4"	7 5/8"	7 3/4"	7 7/8"	8 1/8"		9"
3 1/2"		7 1/4"	7 5/8"	7 3/4"	7 7/8"	8 1/8"		9"
4"		6 5/8"	7 1/4"	7 5/8"	7 3/4"	8"		8 3/8"

**PS 815 - Two-Piece, Heavy Duty Pipe Roller**

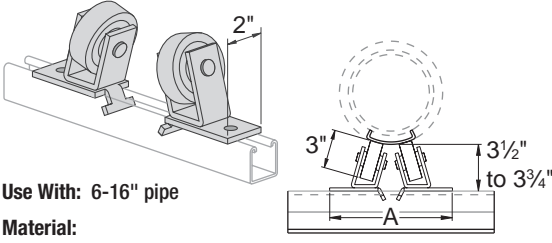

**Use With:** 6-16" pipe  
**Material:**  
 Bracket - steel; Roller - cast iron  
**Finish:** Green or galvanized; Roller - plain  
**Load Rating:** 1500 lbs.  
 Weight/100 pair: 680 lbs.

Chart for Dimension A							
Pipe Size	No Insulation	Insulation Thickness					
		1"	1 1/2"	2"	2 1/2"	3"	4"
6"	9 1/2"	10 1/4"	10 1/2"	10 3/4"	11"	11 3/8"	11 7/8"
8"	10 1/8"	-	11"	11 3/8"	11 3/4"	12"	12 1/2"
10"	10 3/4"		11 5/8"	12"	12 1/4"	12 1/2"	13"
12"	11 1/4"		12 1/8"	12 1/2"	12 3/4"	13"	13 1/2"
14"	11 5/8"		12 1/2"	12 7/8"	13"	13 3/8"	14"
16"	12 1/8"		13"	13 3/8"	13 7/8"	14"	14 1/2"

**PS 1911 - Pipe Roller**

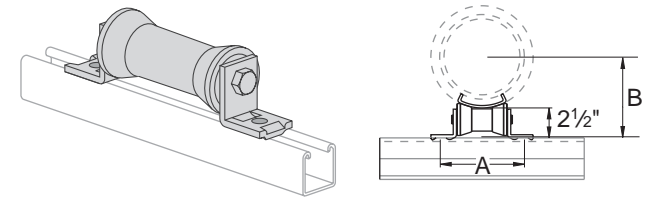

**Material:** Bracket and shaft - steel; Roller - cast iron  
**Finish:** Brackets - painted green or galvanized; Shaft - electro-galvanized;  
 Roller - plain  
**Load Rating:** 950 lbs.

Size	Fits Pipe Size	A	B	Wt./100 pcs
2 - 3-1/2"	2"	5"	3"	160
	2 1/2"		3 1/4"	
	3"		3 5/8"	
4 - 6"	3 1/2"	5"	3 7/8"	215
	4"	5 7/8"	4 5/16"	
	5"	4 7/8"		
8 - 10"	6"	5 7/8"	5 7/16"	525
	8"	8 5/16"	7 1/8"	
	10"	8 1/4"		
12 - 14"	12"	10 7/8"	9 7/8"	1,025
	14"		10 1/2"	

**PS 816 - Three Piece, Heavy Duty Pipe Roller**

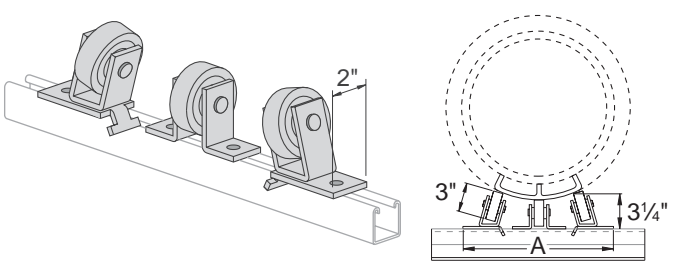

**Use With:** 16-24" pipe  
**Material:** Bracket - steel; Roller - cast iron  
**Finish:** Bracket - painted green or galvanized; Roller - plain  
**Load Rating:** 2,000 lbs.

Chart for Dimension A					
Pipe Size	Insulation Thickness				
	1 1/2"	2"	2 1/2"	3"	4"
16"	-		13 7/8"	14"	14 1/2"
18"	13 5/8"	14"	14 1/8"	14 1/2"	15"
20"	14 1/8"	14 1/2"	14 3/4"	15"	15 1/2"
24"	15 1/4"	15 1/2"	15 5/8"	16 1/8"	16 3/8"

Weight/100 units: 1,046 lbs.

# ROLLERS

Order By: No. and Finish

## PS 1902 - Pipe-Roller Assembly

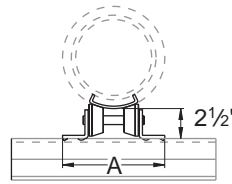
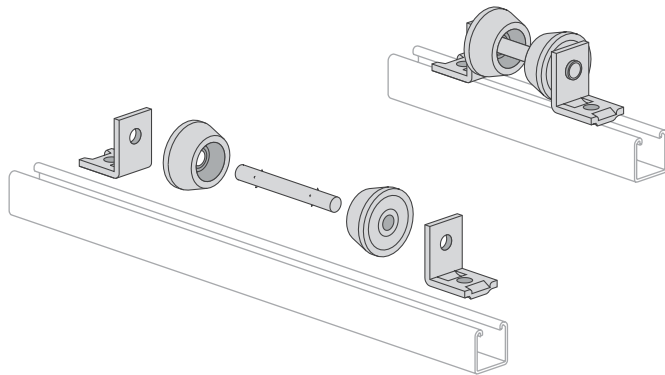

**Material:**

Bracket and shaft - steel;  
Roller - cast iron

**Finish:**

Bracket - painted green or galvanized;  
Shaft - electro-galvanized; Roller - plain

**Load Rating:** 750 lbs.

Part No.	A	Wt./100 pcs.
PS 1902 - 1"-2"	6¾"	299
PS 1902 - 2½"-3½"	7½"	304
PS 1902 - 4"-6"	8½"	311
PS 1902 - 8"	9½"	319

Pipe Size	No Insulation	Insulation Thickness					
		1"	1½"	2"	2½"	3"	4"
½"	PS 1902 - 1"-2"	PS 1902 - 1"-2"	PS 1902 - 1"-2"	PS 1902 - 2½"-3½"	-	-	-
¾"							
1"							
1¼"		PS 1902 - 2½"-3½"	PS 1902 - 2½"-3½"	PS 1902 - 2½"-3½"	-	-	-
1½"							
2"							
2½"							
3"	PS 1902 - 4"-6"	PS 1902 - 4"-6"	PS 1902 - 4"-6"	PS 1902 - 4"-6"	PS 1902 - 4"-6"	PS 1902 - 4"-6"	
3½"							
4"							
5"							
6"							
8"	PS 1902 - 2½"-3½"	PS 1902 - 4"-6"	PS 1902 - 4"-6"	PS 1902 - 4"-6"	PS 1902 - 8"	PS 1902 - 8"	

## PS PP - Power-Pier

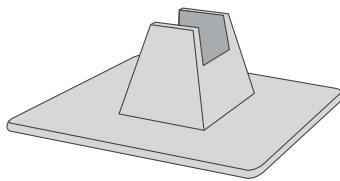

Part Number	Power-Pier Bases Qty.	Description
PS PP	4	Power-Pier Base Only (4 Bases & Hardware)
PS-SPSS-6 HG	4	PS PP + 4 Pcs PS 500 EH HG @ 6" Long for up to 3½" Pipe
PS-SPSS-10HG	4	PS PP + 4 Pcs PS 500 EH HG @ 10" Long for 4" to 8" Pipe
PS-MPDS-26HG	4	PS PP + 2 Pcs PS 200 EH HG @ 26" Long for Trapeze
PS-MPDS-38HG	4	PS PP + 2 Pcs PS 200 EH HG @ 38" Long for Trapeze
PS-MPDS-50HG	4	PS PP + 2 Pcs PS 200 EH HG @ 50" Long for Trapeze
PS-MPDS-62HG	4	PS PP + 2 Pcs PS 200 EH HG @ 62" Long for Trapeze

The Power-Pier Rooftop support system provides a simple and versatile way to support and manage pipe, tubing, conduit, HVAC systems, and the like. The Power-Pier system supports without roof surface penetration and allows the parts to remain off the surface

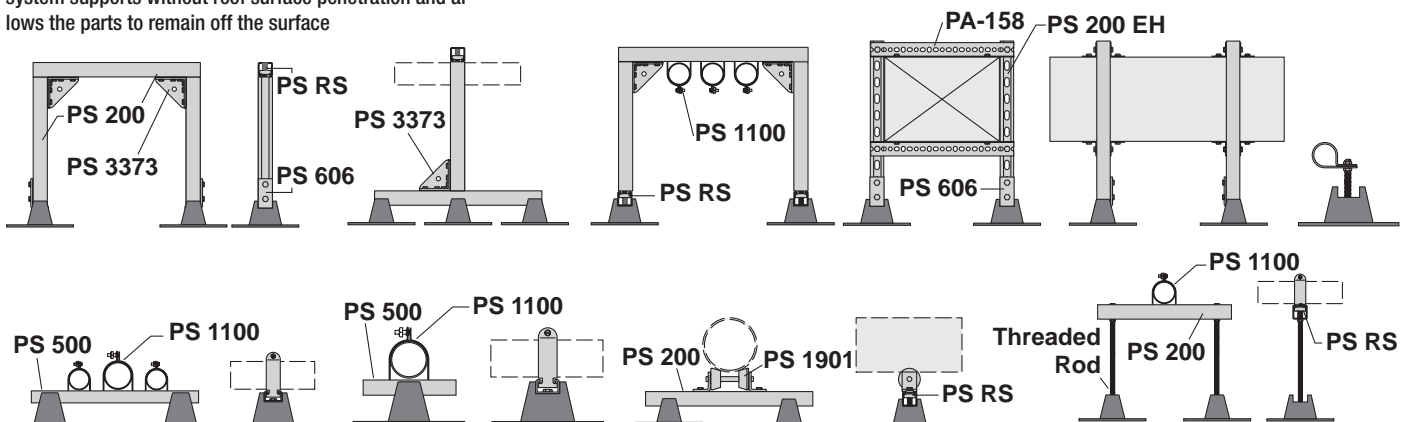

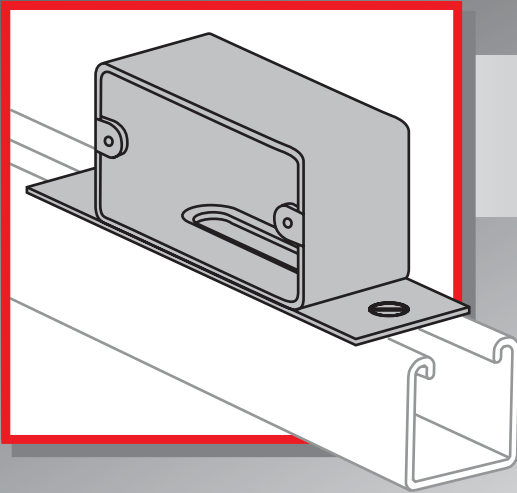

## ELECTRICAL

*Power-Strut offers a versatile means of supporting lighting, conduits, cable and other portions of an electrical system. Power-Strut is listed as an electrical raceway by Underwriters laboratories as specified by the National Electrical Code (Article 384), and CSA approved in accordance with the Canadian Electrical Code (Part 1).*

---

### **MATERIAL:**

Power-Strut electrical raceways are cold formed from low carbon steel and meet the requirements of ASTM A575, A576, A635, A1011 SS GR 33, A1011 HSLAS GR 45, or A36. The fitting steel also meets or exceeds the physical requirements of ASTM A1011 SS GR 33.

---

### **STANDARD LENGTHS:**

Standard lengths of electrical raceway are 10 and 20 feet. The Power-Strut closure strips are available only in 10 foot lengths.

---

### **STANDARD FINISH:**

Electrical raceway channel is available in a painted green or pre-galvanized finish. All Power-Strut fittings are available in painted green or electro-galvanized finish. Many fittings are available in pre-galvanized or hot-dipped galvanized.

---

### **ORDERING INFORMATION:**

When ordering, add the length or size and finish to the part number. See pages 8-9 for finish abbreviations and an example.

---

### **LISTINGS:**

UL File No. E27817 - Channel & Closure Strips  
UL File No. E27818 - Fittings  
CSA File No. 091312

Finish: Painted Green or Pre-Galvanized Stock Length: 10' & 20' Order By: No. and Finish

## Solid Raceway \*

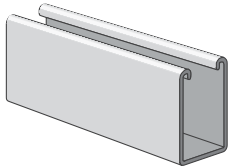

Part No.	Section Height
PS 100	3/4"
PS 150	2 7/16"
PS 200	1 5/8"
PS 210	1 5/8"
PS 300	1 3/8"
PS 400	1"
PS 500	1 3/16"

## Knock-Out Raceway \*

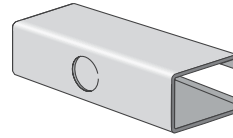

Part No.	Section Height
PS 100 K06	3/4"
PS 150 K06	2 7/16"
PS 200 K06	1 5/8"
PS 210 K06	1 5/8"
PS 300 K06	1 3/8"
PS 400 K06	1"

## Maximum Number of Wires Types

AVB, FEP, FEBP, RH, RHH, RHW, RUH, RUW, T, TW, THHN, THWN, THW, XHHW

	Raceway Part Numbers	Wt./ 100 Ft.	Height of Section Inches	Wire Size AWG*				
				14	12	10	8	6
<b>Table A</b> – Maximum number of conductors when raceway is installed to support and supply electric discharge type lighting fixtures when raceway wiring is suitable for at least 75 C. EXCEPTION: Wire suitable for 60 C may be used when clearance between raceway and fixtures is at least 1/2 inch.	PS 100, PS 100 K06	305	3/4"	10	10	8	6	4
	PS 150, PS 150 K06	247	2 7/16"	10	10	8	6	4
	PS 200, PS 200 K06	190	1 5/8"	6	6	5	4	2
	PS 210, PS 210 K06	141	1 5/8"	6	6	5	4	2
	PS 300, PS 300 K06	170	1 3/8"	5	4	4	3	2
	PS 400, PS 400 K06	146	1"	4	3	0	0	0
	PS 500	97	1 3/16"	4	3	0	0	0
<b>Table B</b> – Maximum number of conductors when raceway is installed to support and supply electric discharge type lighting fixtures when raceway wiring is suitable for at least 75 C and clearance between raceway and fixtures is at least 1/8 inch.	PS 100, PS 100 K06	305	3/4"	10	10	10	9	6
	PS 150, PS 150 K06	247	2 7/16"	10	10	10	8	6
	PS 200, PS 200 K06	190	1 5/8"	10	10	8	6	3
	PS 210, PS 210 K06	141	1 5/8"	10	10	8	6	3
	PS 300, PS 300 K06	170	1 3/8"	10	10	6	4	2
	PS 400, PS 400 K06	146	1"	6	6	0	0	0
	PS 500	97	1 3/16"	6	6	0	0	0
<b>Table C</b> – Maximum number of conductors when raceway is not employed with fixtures OR where the clearance between the raceway and fixtures is greater than 1/2 inch.	PS 100, PS 100 K06	305	3/4"	50	42	35	20	13
	PS 150, PS 150 K06	247	2 7/16"	36	29	25	14	9
	PS 200, PS 200 K06	190	1 5/8"	22	18	15	9	5
	PS 210, PS 210 K06	141	1 5/8"	24	20	17	10	6
	PS 300, PS 300 K06	170	1 3/8"	18	15	13	7	5
	PS 400, PS 400 K06	146	1"	11	9	7	4	3
	PS 500	97	1 3/16"	9	7	6	4	2
<b>Table D</b> – CSA Certified Maximum number of wires Types R, RW, RWU, T, TW	PS 100, PS 100 K06	305	3/4"	10	10	8	6	4
	PS 150, PS 150 K06	247	2 7/16"	10	10	8	6	4
	PS 200, PS 200 K06	190	1 5/8"	8	8	5	4	3
	PS 210, PS 210 K06	141	1 5/8"	8	8	5	4	3
	PS 300, PS 300 K06	170	1 3/8"	8	6	5	3	2
	PS 400, PS 400 K06	146	1"	4	3	0	0	0
	PS 500	97	1 3/16"	4	3	0	0	0

\*In all cases, the snap-in-cover, PS 707, is required to complete raceway enclosures.

Also UL Listed: PS 100 2T3, PS 150 2T3, PS 200 2T3, PS 210 2T3, PS 300 2T3, PS 400 2T3, and PS 500 2T3

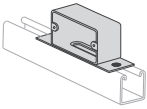

Metal Channel  
Fasteners  
Fittings  
Pipe & Conduit Clamps  
Electrical  
Concrete Inserts  
Solar Components  
Unipier®  
Jr. Channel  
Power-Angle  
Fiberglass  
Tech. Data

**To Install Channel**

1. Suspend and align PS-2632 Channel hanger from threaded rod at pre-determined level.

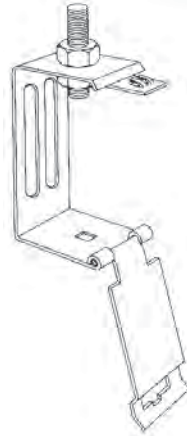

2. At floor working level install wiring in channel raceway and add a channel closure strip.

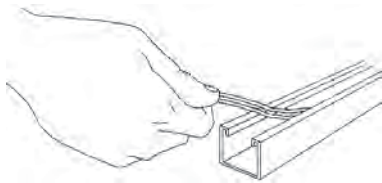

3. Lay raceway into pre-hung channel hanger. Close snap fastening door which securely locks raceway into position.

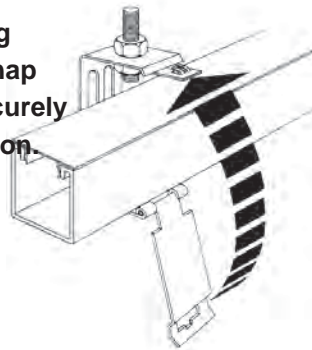

**To Install Fluorescent Fixture**

1. Attach PS2631 Fixture Hanger to fixture with quick assembly wing-nut leaving door open.

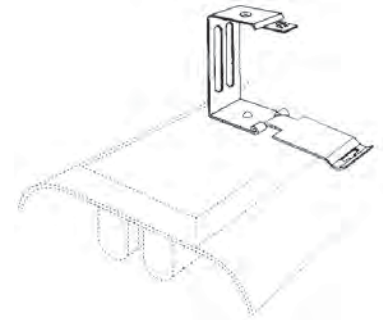

2. Hook fixture over raceway. Close snap fastening door which securely locks fixture into position. Plug in fixture.

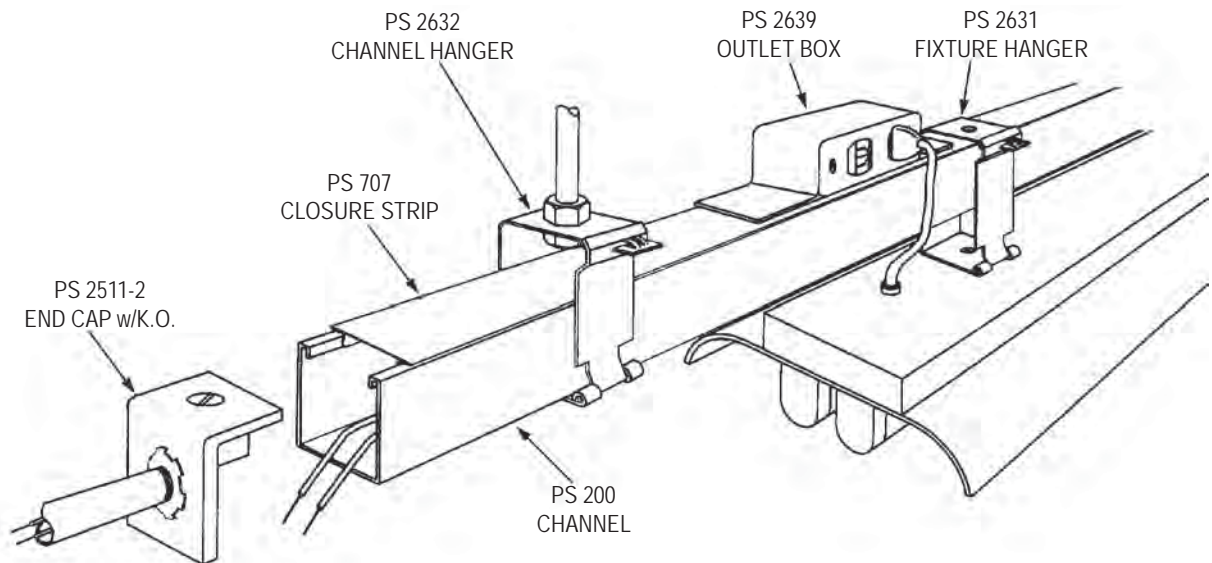
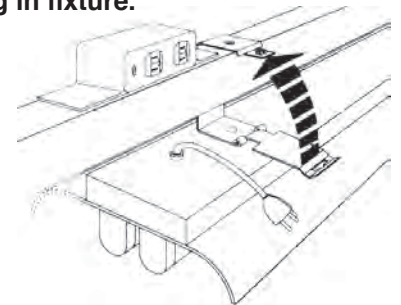

Complete installation in minutes. No screw, bolts or cotter pins to lose.



## Knock-out Fluorescent Raceway System

Listed by Underwriter's Laboratories, Inc. Fixture is attached to slot-up channel with chase nipple, locknut and bushing through knock-outs in bottom of channel. Conduit connector fitting PS-2560 holds channel and fixture to pipe or rod.

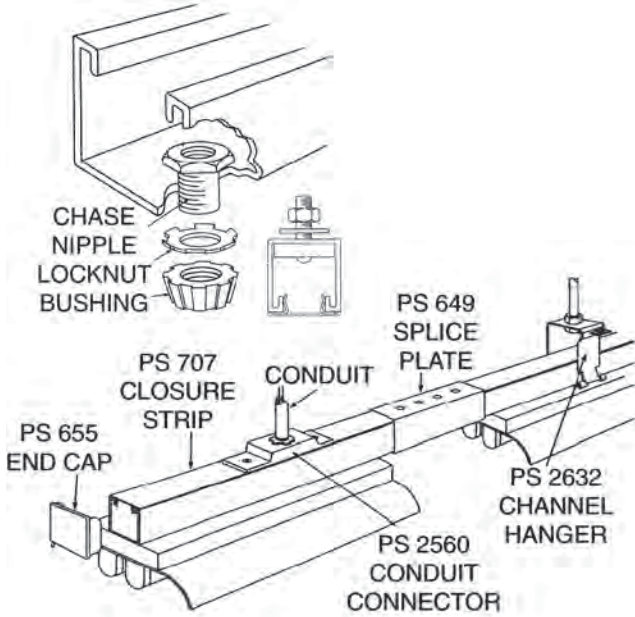

## Basic Fluorescent Support System

Slot-down channel holds fixture firmly in place with spring nut and bolt. Fixtures may be added or relocated without changing the basic assembly.

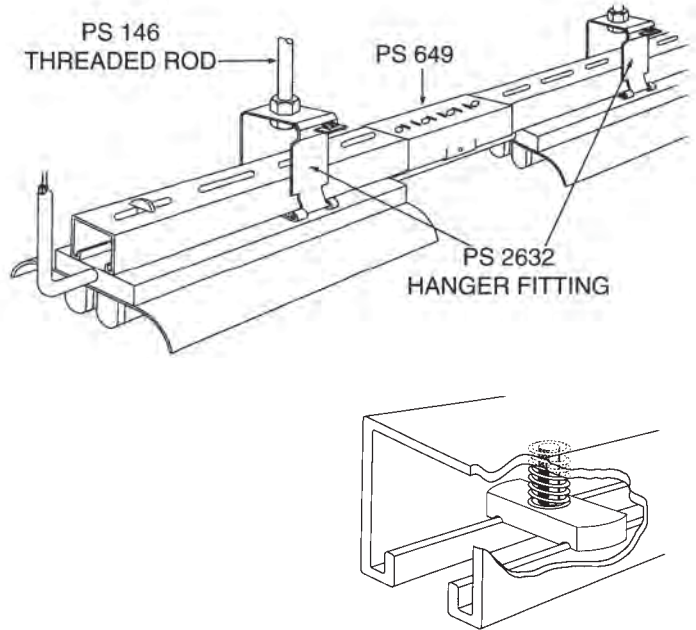

## Economy Raceway System Fluorescent

In this slot-down system the circuits run through the fixtures and only enter the channel where there is a break in the fixture run. At that point the fiber wire retainer holds wires in place and snap-in closure strip covers the area.

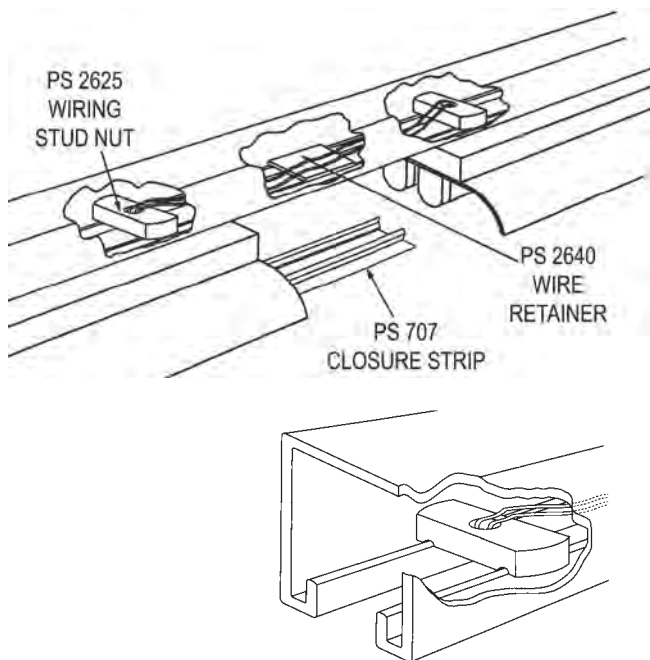

## Knock-out Mercury Vapor Raceway System

Listed by Underwriter's Laboratories, Inc. Fixture is attached to slot-up channel with chase nipple, locknut and bushing through knock-outs in bottom of channel. Conduit connector fitting PS-2561 holds channel and fixture to pipe or rod.

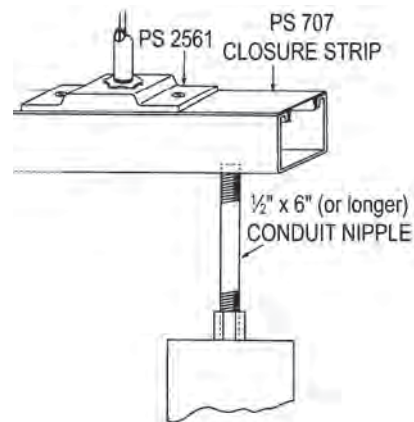

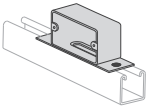

Metal Channel  
Fasteners  
Fittings  
Pipe & Conduit Clamps  
Electrical  
Concrete Inserts  
Solar Components  
Unipier®  
Jr. Channel  
Power-Angle  
Fiberglass  
Tech. Data

**Basic Mercury Vapor Support System**  
PS 3301 Clevis Hanger for use with PS 150, PS 200

In this slot up or down system, the fixture is supported by PS-3301 clevis hanger which is designed for use with both 1 5/8" and 2 7/16" deep channels.

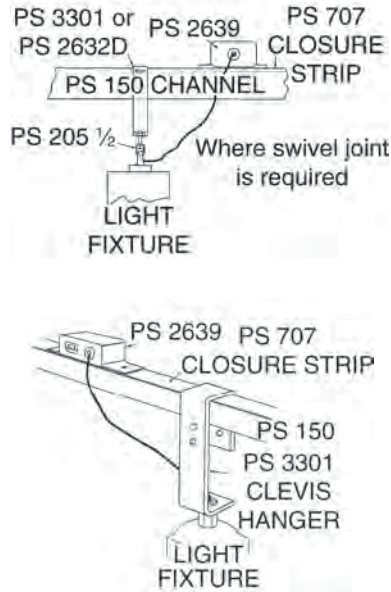

**Slot Down Mercury Vapor System**

In this slot down system the mercury vapor ballast is wired directly to the system.

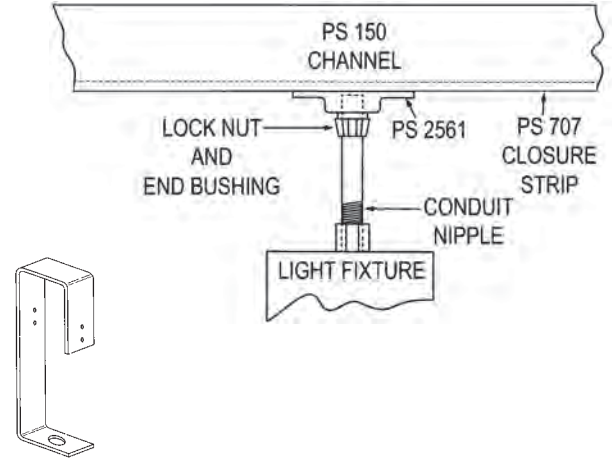

**Slotted Support System**

This system is designed for maximum ease of attaching fixture through slotted channel with shoulder bolt and provides positive alignment.

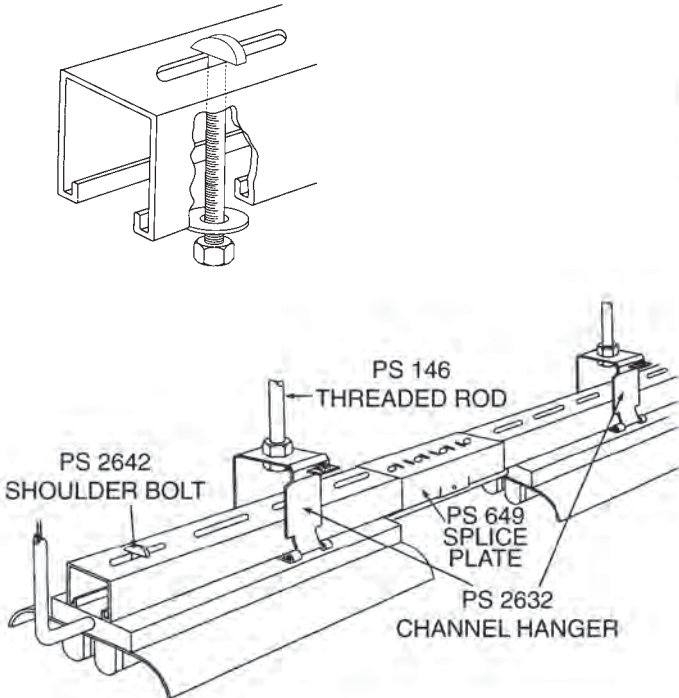

**Grid System**

This system is used where fixtures are hung at right angles to Power-Strut raceways and support channels. Any of the features of the above systems can be adapted to this system. Ideal for egg-crate type drop ceiling installations.

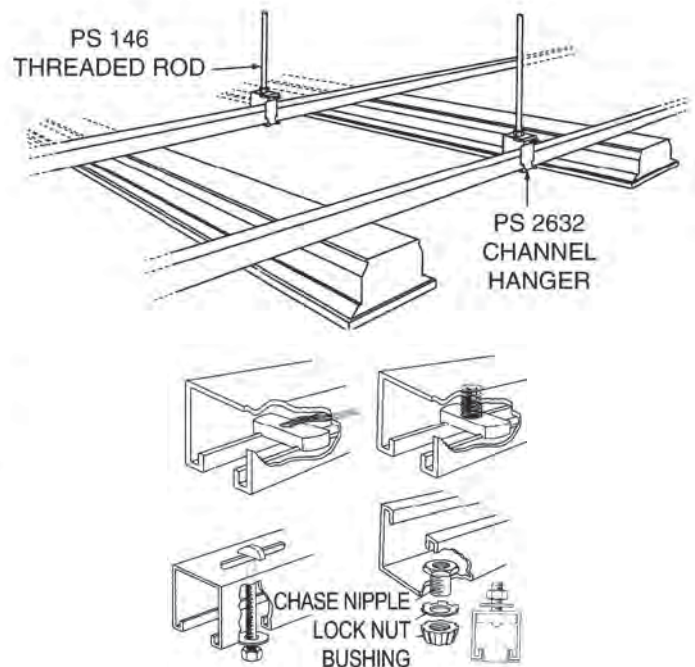

Finish: Electro-galvanized **Order By:** No. and Finish

## PS 655, PS 656, PS 901, PS 902, PS 930, PS 2580, PS 2585 – Raceway End Caps

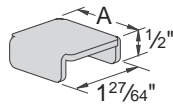

Part No.	Use With	Finish	A	Wt./100 pcs
PS 902	PS 100	EG	3 1/4"	22
PS 2580	PS 150		2 7/16"	18
PS 655	PS 200		1 5/8"	11
PS 2585	PS 210		1 5/8"	12
PS 656	PS 300		1 3/8"	15
PS 901	PS 400		1"	11
PS 930	PS 500		1 3/16"	5

## PS 2560, PS 2561 – Conduit Connector Fitting

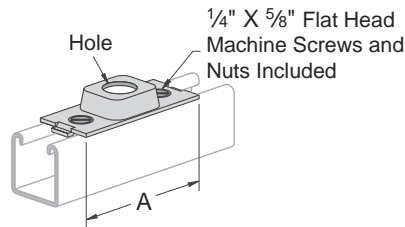

Stock Size: (.060)

Assembly: Connector Fitting, 2 Nuts, 2 Bolts

Part No.	Use With	A	Hole	Design Load (lbs.)	Wt./100 pcs
PS 2560	1/2 Conduit"	4"	7/8"	400	36
PS 2561	3/4 Conduit"	5 1/8"	1 1/32"	200	36

## PS 803 – Fixture Wiring Nipple

Assembly: 1/2" x 2" rigid conduit nipple  
Bushing Locknut

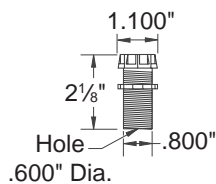

Weight/100 pcs: 14 lbs.

## PS 707, PS 707 P – Raceway Closure Strip

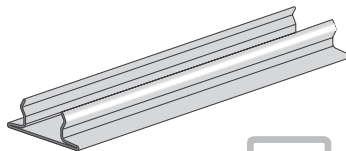

Material/Finish:

PS 707 P - Green and gray

PS 707 - Painted green and pre-galvanized

Stock Size: (.040) GRN, (.040) PGAL

Stock Length: 10 ft.

Use With: All 1 1/8" wide channel.

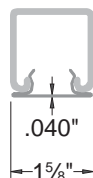

Weight 47 Lbs./ft.

## PS 2511, PS 2581 – End Cap With Knock-Out



1/4" X 5/8" Flat Head  
Machine Screw and  
Nut Included

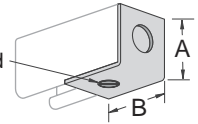

Assembly:

End Cap Part, 1 Machine Screw, 1 Nut  
Specify 1/2" or 3/4" knock-out

Part No.	Use With	Finish	A	B	Wt./100 pcs
PS 2511-1	PS 100	EG	3 1/4"	1 3/4"	3.1
PS 2511-2	PS 200, PS 210		1 5/8"	1 3/4"	2.7
PS 2511-3	PS 300		1 3/8"	1 3/4"	2.6
PS 2581	PS 150		2 7/16"	2"	3.0

## PS 2625 – Wiring Stud Nut

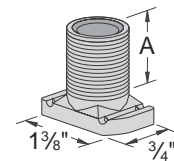

Material: Sintered Iron

Size: 1/2" - 14 Amer. Std, conduit thread

Part No.	A	Identification No.
PS 2625-1/2	1 5/64"	121961
PS 2625-2-5/8	5/8"	121960

Weight/100 pcs: 10 lbs.

## PS 2640 – Wire Retainer

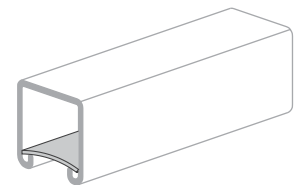
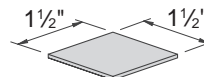

Material: Polypropylene

Weight/100 pcs: .30 lbs.

## PS 707 – Aluminum Raceway Closure Strip

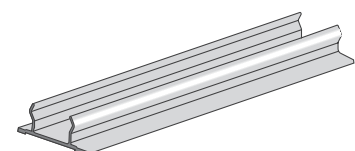

Material:

6063-T6 Aluminum, Copper Free, Extruded

Stock Size: (.051)

Stock Length: 10 ft.

Use With: All 1 1/8" wide channel

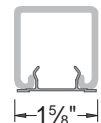

Weight 21 Lbs./ft.

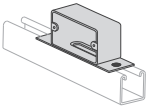

Metal Channel  
Fasteners  
Fittings  
Pipe & Conduit/Clamps  
Electrical  
Concrete Inserts  
Solar Components  
Unipier®  
Jr. Channel  
Power-Angle  
Fiberglass  
Tech. Data

**PS 2632 – Swing Gate Channel Hanger**

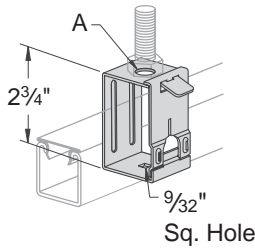

A Dia.	Use With
9/16"	1/2" Rod
7/8"	1/2" Conduit

**Finish:** Electro-galvanized  
**Use With:** PS 200, PS 210, PS 300, PS 400 and PS 500  
**Load Rating:** 90 lbs.

Weight/100 pcs: 25 lbs.

**PS 2631 – Swing Gate Fixture Hanger**

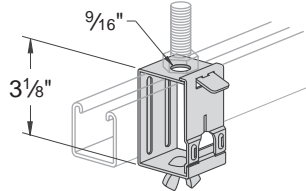

**Use With:** PS 200, PS 210, PS 300, PS 400 and PS 500  
**Load Rating:** 90 lbs.  
**Note:** Includes Bolt and Wing Nut for connection to fluorescent fixtures.

Weight/100 pcs: 27 lbs.

**PS 3301 – Mercury Vapor Fixture Hanger**

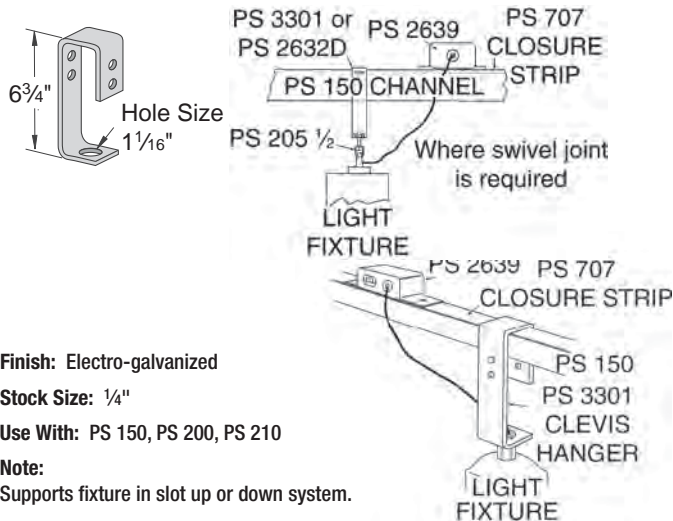

**Finish:** Electro-galvanized  
**Stock Size:** 1/4"  
**Use With:** PS 150, PS 200, PS 210  
**Note:** Supports fixture in slot up or down system.

Weight/100 pcs: 154 lbs.

**PS 2632D – Swing Gate Channel Hanger**

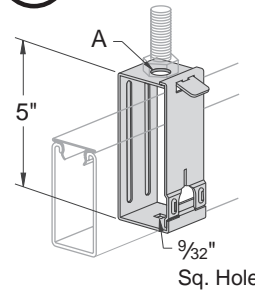

A Dia.	Use With
9/16"	1/2" Rod
7/8"	1/2" Conduit

**Finish:** Electro-galvanized  
**Use With:** PS 100, PS 150, PS 200 2T3, and PS 210 2T3  
**Load Rating:** 90 lbs.

Weight/100 pcs: 34 lbs.

**PS 2631D – Swing Gate Fixture Hanger**

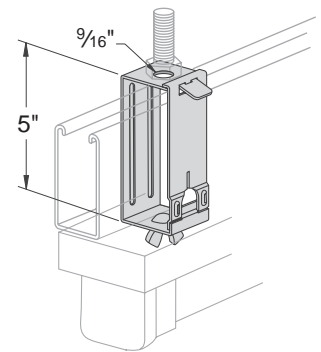

**Use With:** PS 100, PS 150, PS 200 2T3, PS 210 2T3  
**Load Rating:** 90 lbs.  
**Note:** Includes Bolt and Wing Nut for connection to fluorescent fixtures.

Weight/100 pcs: 36 lbs.

**PS 807 – Channel Hanger**

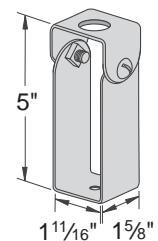

**Use With:** PS 100, PS 150  
**Load Rating:** 150 lbs.  
**Note:** Washers supplied to adapt to 3/8" or 1/2" rod

Weight/100 pcs: 35 lbs.

Order By: No. and Finish

## PS 2636 - Fixture Stud Nut

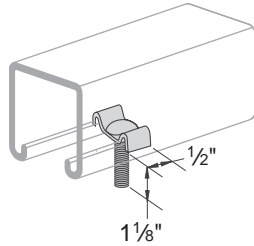

Size: 1/4" x 20 thread, 1 1/4" long

Weight/100 pcs: 5 lbs.

## PS 702 - Fluorescent Fixture Hanger

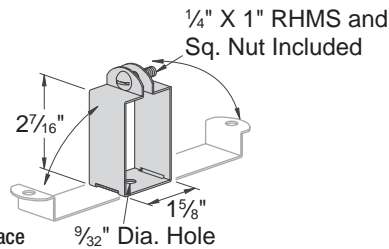

Hanger provides more than 1/2" space between channel and fixtures.

Use hanger for PS 200, PS 210 & PS 300.

Load Rating: 120 lbs.

Weight/100 pcs: 19 lbs.

## PS 702 D - Fluorescent Fixture Hanger

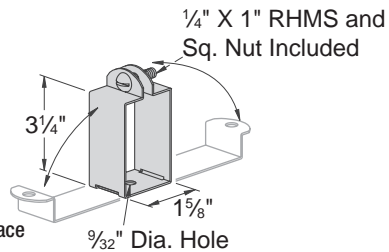

Hanger provides more than 1/2" space between channel and fixtures.

Use hanger for PS 150.

Load Rating: 120 lbs.

Weight/100 pcs: 20 lbs.

## PS 659 - Channel Hanger

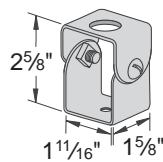

Use With: PS 400, PS 500

Load Rating: 150 lbs.

Note:  
Washers supplied to adapt to 3/8" or 1/2" rod

Weight/100 pcs: 28 lbs.

## PS 2637 - Fixture Nut

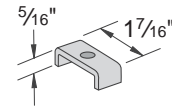

Size: Tapped for 1/4" - 20 thread

Weight/100 pcs: 2 lbs.

## PS 703 - Fluorescent Fixture Hanger

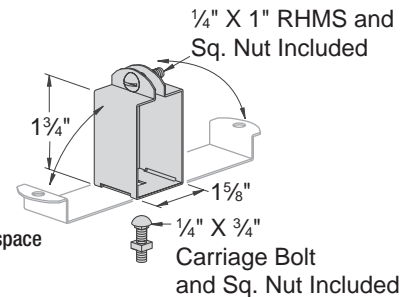

Hanger provides more than 1/8" space between channel and fixtures.

Use hanger for PS 200 & PS 210.

Load Rating: 120 lbs.

Weight/100 pcs: 17 lbs.

## PS 703 D - Fluorescent Fixture Hanger

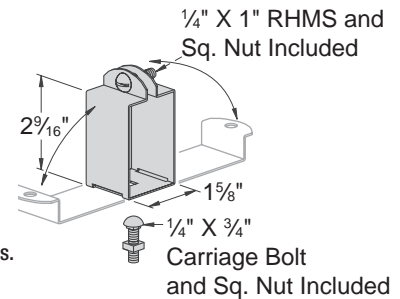

Hanger provides more than 1/8" space between channel and fixtures.

Use hanger for PS 150.

Load Rating: 120 lbs.

Weight/100 pcs: 18 lbs.

## PS 658 - Channel Hanger

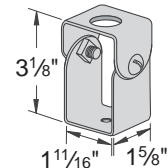

Use With: PS 200, PS 210, PS 300

Load Rating: 150 lbs.

Note:  
Washers supplied to adapt to 3/8" or 1/2" rod

Weight/100 pcs: 30 lbs.

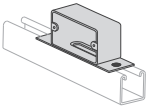

Metal Channel  
Fasteners  
Fittings  
Pipe & Conduit Clamps  
Electrical  
Concrete Inserts  
Solar Components  
Unipier®  
Jr. Channel  
Power-Angle  
Fiberglass  
Tech. Data

**PS 2621 - Conduit Swing Fitting**

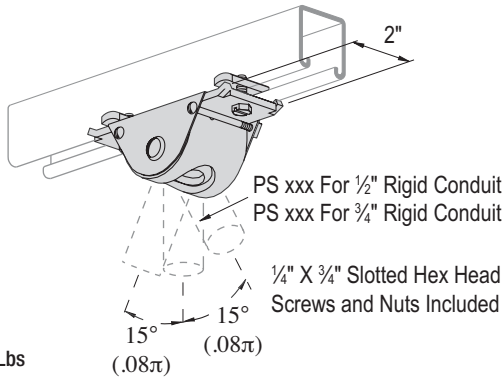

**Design Load:** 300 Lbs

**Note:**

Conduit hanger fittings allow a free swivel of 15° in one direction.

Fitting may be mounted to the slot side of the channel or to the back

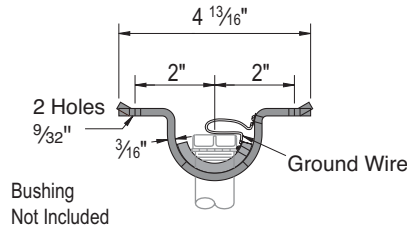

Weight/100 pcs: 396 lbs.

**PS 2094 - 4" Receptacle Box With Knock-outs**

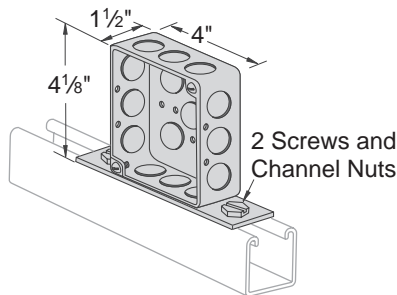

**Stock Size:** (.075)

**Assembly:** 1 Box, 2 Screws

Weight/100 pcs: 93 lbs.

**PS 2639 - Outlet Box**

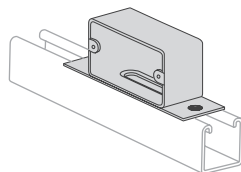

**Stock Size:** (.075)

**Assembly:** 1 Box, 2 Screws, 2 Channel Nuts

Weight/100 pcs: 88 lbs.

**PS 2662 A - Hub Assembly**

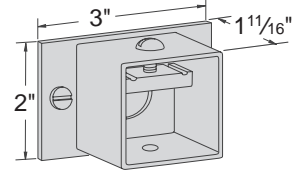
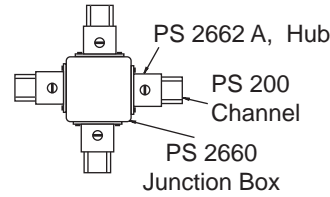

**Use With:** PS 200, PS 210

**Assembly:** 1 Hub, 2 Screws, 1 Bolt, 1 Nut

**Note:** Add hub assemblies to the basic PS 2660 unit assembly to make 1, 2, 3 or 4-way junction box.

Identification No. 122022

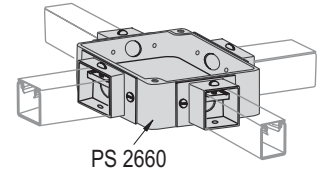

Weight/100 pcs: 27 lbs.

**PS 2660 - Junction Box**

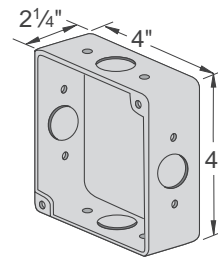

**Note:**

Add hub assemblies PS 2662-A to make 1, 2, 3 or 4-way junction box.

Weight/100 pcs: 113 lbs.

**PS 2661 - Junction Box Cover**

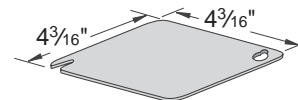

Weight/100 pcs: 30 lbs.

Order By: No. and Finish

**PS 649, PS 693, PS 694, PS 805, PS 942, PS 2582 – Electrical Joiner**

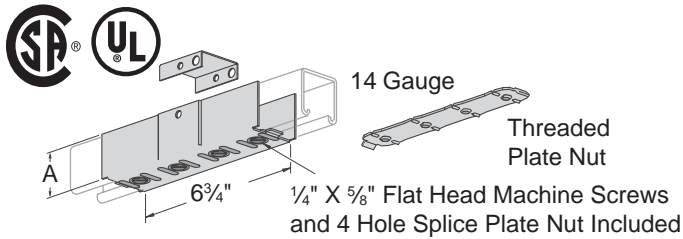

Stock Size: (.060)

Assembly: 1 Splice Plate Clevis (GRN),  
1 Tapped Plate (EG), 1 Backplate (GRN),  
4 Flat Head Machine Screws (EG).

Part No.	A	Use With	Finish	Wt./100 pcs
PS 805		PS 100	EG, GRN	106
PS 2582	1 5/8"	PS 150	EG	103
PS 649		PS 200, PS 210	EG, GRN	100
PS 694	1 3/8"	PS 300		97
PS 693	1 1/16"	PS 400		97
PS 942	1 3/16"	PS 500, PS 520		80

**PS 2700 – Inside Strut Joiner**

Material: Extruded aluminum  
Jam screws included

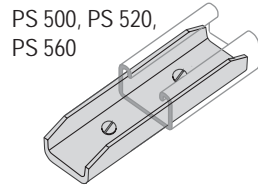

PS 500, PS 520,  
PS 560

Weight/100 pcs: 12 lbs.

**PS 2800 – Inside Strut Joiner**

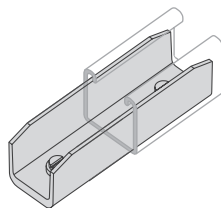

Material: Cast aluminum or electro-galvanized  
Jam screws included  
Note: Electro-galvanized is not UL Listed

Weight/100 pcs: 20 lbs.

**PS 2803 – "Cross" Inside Strut Joiner**

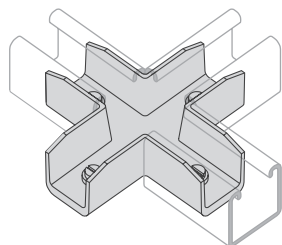

Material: Cast aluminum  
Jam screws included

Weight/100 pcs: 45 lbs.

**PS 671 – Strut Suspension Member**

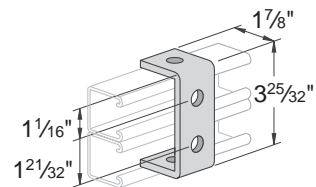

Weight/100 pcs: 70 lbs.

**PS 2802 – "Elbow" Inside Strut Joiner**

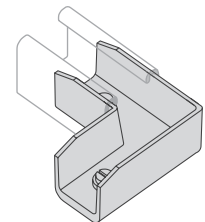

Material: Cast aluminum  
Jam screws included

Weight/100 pcs: 27 lbs.

**PS 2801 – "T" Inside Strut Joiner**

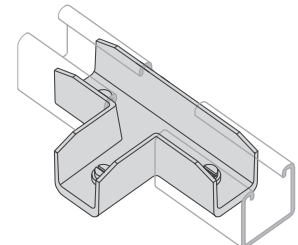

Material: Cast aluminum  
Jam screws included

Weight/100 pcs: 35 lbs.

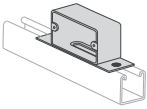

Metal Channel  
Fasteners  
Fittings  
Pipe & Conduit Clamps  
Electrical  
Concrete Inserts  
Solar Components  
Unipier®  
Jr. Channel  
Power-Angle  
Fiberglass  
Tech. Data

**PS 791 - Electrical Box Adapter Plate**

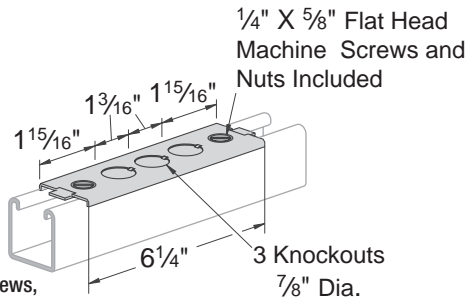

Stock Size: (.060)

Assembly: 1 Plate, 2 Screws,  
2 Channel Nuts

Weight/100 pcs: 35 lbs.

**PS 2627 - Spacer Clevis**

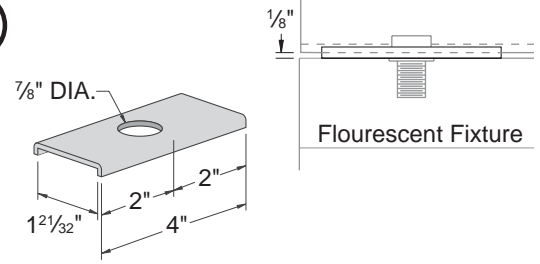

Material: 12 ga.

Weight/100 pcs: 24 lbs.

**PS 1500 - Porcelain Cable Rack Insulators**

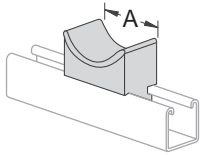

Cable Diameter	A	Wt./100 pcs
3"	3"	75
4 1/2"	4"	95

Use With: All 1 5/8" channel

**PS 760 - Bus Duct Connection Clevis**

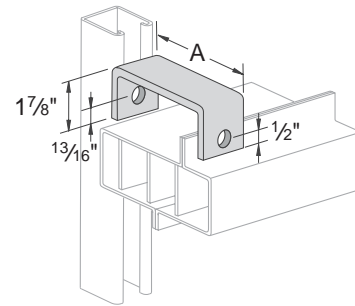

Part No.	Outside Width	Inside Width	Wt./100 pcs
PS 760-1	2 13/32"	1 29/32"	57
PS 760-2	3 25/32"	3 9/32"	73
PS 760-3	4 3/4"	4 1/4"	84

Weight/100 pcs: 93 lbs.



Finish: Electro-galvanized Stock Length: 10' & 20' Order By: No. and Finish

**PS 722 - Porce -A- Clamp™**

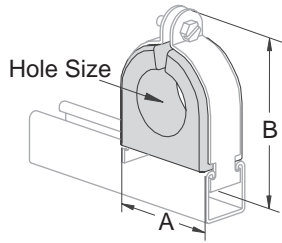

**Porce -A- Clamp™**

- Non-Breakable Material
- Chemical and UV Resistant
- U.L. Listed
- Electro-galvanized or Stainless Steel Clamps
- Tapered Flange to Protect Cable
- Dielectric Strength 640 Volts Per Mil.
- One Piece
- Replaces Porcelain & Maple Cable Clamp
- For use in accordance with National Electrical Code ANSI/NFPA 70.

Replaces the two piece PS 723 Porcelain Cable Clamp

**Includes:** Everdur Hardware

Patents Pending

**Strap Material:** Electro-galvanized steel or stainless steel

**Use With:** All 1 5/8" channel

**Temperature Range:** -50°F to +275°F

Part No.	Hole Size	A	B	Wt./100 pcs
PS722 3/8"	3/8"	1.12"	1.82"	25
PS722 1/2"	1/2"			
PS722 5/8"	5/8"			
PS722 3/4"	3/4"	1.62"	2.34"	37
PS722 7/8"	7/8"			
PS722 1"	1"			
PS722 1 1/8"	1 1/8"			
PS722 1 1/4"	1 1/4"			
PS722 1 3/8"	1 3/8"	2.12"	2.86"	58
PS722 1 1/2"	1 1/2"			
PS722 1 5/8"	1 5/8"			
PS722 1 3/4"	1 3/4"	2.62"	3.50"	76
PS722 1 7/8"	1 7/8"			
PS722 2"	2"			
PS722 2 1/8"	2 1/8"			
PS722 2 1/4"	2 1/4"			
PS722 2 3/8"	2 3/8"	3.12"	4.05"	90
PS722 2 1/2"	2 1/2"			
PS722 2 5/8"	2 5/8"			
PS722 2 3/4"	2 3/4"	3.62"	4.75"	109
PS722 2 7/8"	2 7/8"			
PS722 3"	3"			
PS722 3 1/8"	3 1/8"			
PS722 3 1/4"	3 1/4"			
PS722 3 3/8"	3 3/8"	4.12"	5.125"	130
PS722 3 1/2"	3 1/2"			
PS722 3 5/8"	3 5/8"			
PS722 3 3/4"	3 3/4"			
PS722 3 7/8"	3 7/8"			
PS722 4"	4"	4.62"	5.54"	160
PS722 4 1/8"	4 1/8"			
PS722 4 1/4"	4 1/4"			
PS722 4 3/8"	4 3/8"			
PS722 4 1/2"	4 1/2"			
PS722 4 3/4"	4 3/4"	5.00"	5.92"	160
PS722 4 7/8"	4 7/8"			

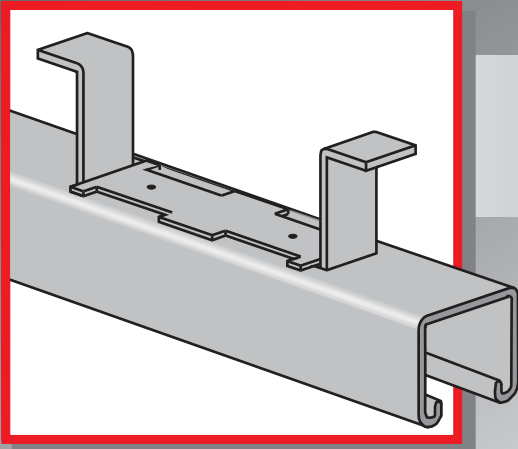

## CONCRETE INSERTS

*A selection of heavy-duty to light-duty “continuous” and “spot” concrete inserts is available for use in pre-cast, pre-stressed or poured-in-place concrete floors, walls or ceilings.*

### **MATERIAL:**

Cold-formed inserts are manufactured from standard 12 gauge Power-Strut channel sections meeting or exceeding the physical requirements of ASTM A1011 SS GR 33.

### **STANDARD LENGTHS:**

Standard lengths are 10 or 20 feet. Non-standard lengths from 3 inches to 20 feet are also available.

### **STANDARD FINISH:**

Power-Strut continuous-slotted concrete inserts are available in plain, pre-galvanized or hot-dipped galvanized finishes. Closure strips (CS) are made of plastic and end caps (EC) are pre-galvanized.

### **ORDERING INFORMATION:**

When ordering, add the length or size and finish to the part number. See pages 8-9 for finish abbreviations and an example.

# CONCRETE INSERTS

**Finish:** Plain, Hot-Dipped Galvanized, or Pregalvanized **Stock Length:** 20', Other lengths made to order  
**Stock Thickness:** .105 (12 ga.) **Order By:** No., Size, Length and Finish

**PS 349 – Continuous Concrete Insert (1<sup>5</sup>/<sub>8</sub>" x 1<sup>3</sup>/<sub>8</sub>")**

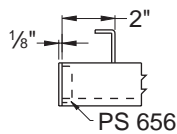
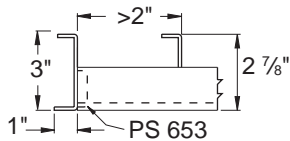
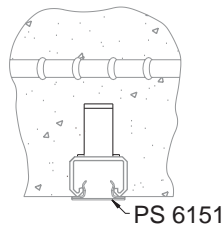
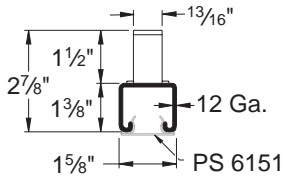
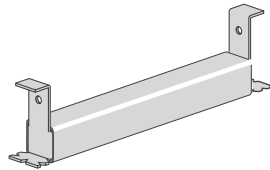
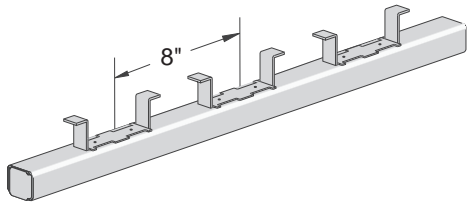

Choice of end cap is based on the distance from the end of the insert to the first anchor as shown below.

Furnished with steel end caps and plastic closure strips installed

- Use channel nuts designed for PS 300 Channel.
- Nail or anchor the inserts to forms every 16" to 24"

Part No.	End Cap	Wt./100 pcs - PLN	Load Data*	
PS 349 3" CS/EC	PS 653	72	500 lbs.	
PS 349 4" CS/EC		87	600 lbs.	
PS 349 6" CS/EC		117	800 lbs.	
PS 349 8" CS/EC		147	1,200 lbs.	
PS 349 1' CS/EC		194	2,000 lbs./ft.	
PS 349 1'4" CS/EC	PS 656	253		
PS 349 1'8" CS/EC	PS 653	312		
PS 349 2' CS/EC	PS 656	371		
PS 349 2'8" CS/EC		490		
PS 349 3' CS/EC	PS 653	549		
PS 349 4' CS/EC	PS 656	727		
PS 349 5' CS/EC	PS 653	905		
PS 349 6' CS/EC	PS 656	1,082		
PS 349 7' CS/EC	PS 653	1,260		
PS 349 8' CS/EC	PS 656	1,438		
PS 349 9' CS/EC	PS 653	1,615		
PS 349 10' CS/EC	PS 656	1,793		
PS 349 12' CS/EC		2,148		
PS 349 14' CS/EC		2,504		
PS 349 16' CS/EC		2,859		
PS 349 18' CS/EC		3,215		
PS 349 20' CS/EC		3,570		
PS 349 10' W/O	Insert Only	1,777		*uniform recommended loading on inserts in 3,000 psi concrete.
PS 349 20' W/O		3,554		

**PS 653 – Type 'B' End Cap**

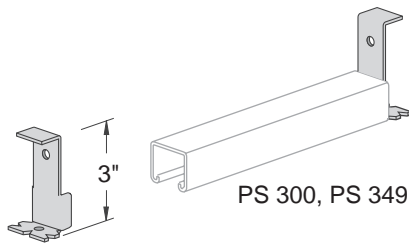

Finish: Pre-galvanized

Weight/100 pcs: 14 lbs.

**PS 654 – Type 'B' End Cap**

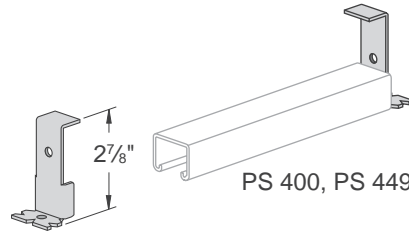

Finish: Pre-galvanized

Weight/100 pcs: 12 lbs.

**PS 1154 – Splice Connection**

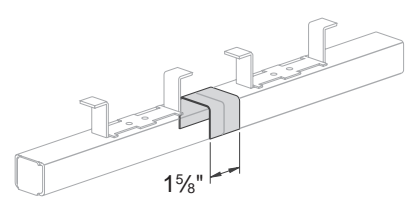

Use With: PS 349

Weight/100 pcs: 10 lbs.

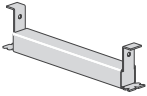

**Finish:** Plain, Hot-Dipped Galvanized, or Pregalvanized **Stock Length:** 20', Other lengths made to order  
**Stock Thickness:** .105 (12 ga.) **Order By:** No., Size, Length and Finish

**PS 449 - Continuous Concrete Insert (1<sup>5</sup>/<sub>8</sub>" x 1")**

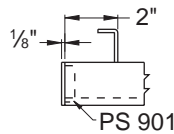
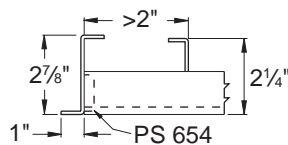
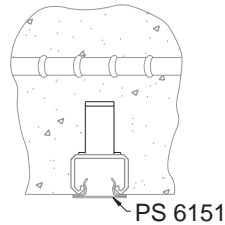
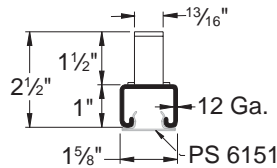
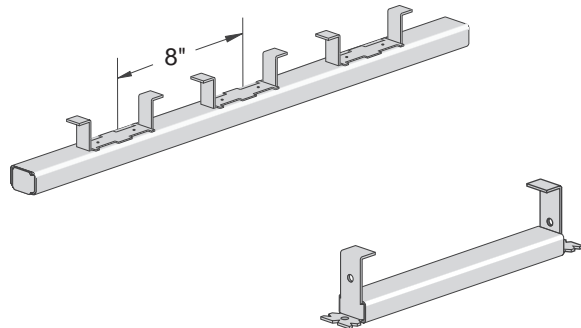

Choice of end cap is based on the distance from the end of the insert to the first anchor as shown below.

Furnished with steel end caps and plastic closure strips installed

- Use channel nuts designed for PS 400 Channel.
- Nail or anchor the inserts to forms every 16" to 24"

Part No.	End Cap	Wt./100 pcs - PLN	Load Data*	
PS 449 3" CS/EC	PS 654	62	500 lbs	
PS 449 4" CS/EC		74	600 lbs.	
PS 449 6" CS/EC		99	800 lbs.	
PS 449 8" CS/EC		124	1,000 lbs.	
PS 449 1' CS/EC		163		
PS 449 1'4" CS/EC	PS 901	213	1,500 lbs./ft.	
PS 449 1'8" CS/EC	PS 654	263		
PS 449 2' CS/EC	PS 901	313		
PS 449 2'8" CS/EC		414		
PS 449 3' CS/EC	PS 654	464		
PS 449 4' CS/EC	PS 901	615		
PS 449 5' CS/EC	PS 654	766		
PS 449 6' CS/EC	PS 901	916		
PS 449 7' CS/EC	PS 654	1,079		
PS 449 8' CS/EC	PS 901	1,218		
PS 449 9' CS/EC	PS 654	1,368		
PS 449 10' CS/EC	PS 901	1,519		
PS 449 12' CS/EC		1,820		
PS 449 14' CS/EC		2,122		
PS 449 16' CS/EC		2,423		
PS 449 18' CS/EC		2,725		
PS 449 20' CS/EC		3,026		
PS 449 10' W/O	Insert Only	1,507		*uniform recommended loading on inserts in 3,000 psi concrete.
PS 449 20' W/O		3,014		

**PS 656, PS 901 - Type 'A' End Cap**



Part No.	Use With Insert	Finish	Wt./100 pcs
PS 656	PS 349	PGAL	8
PS 901	PS 449		6

**PS 6151 - Plastic Closure Strip**

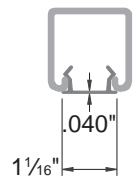
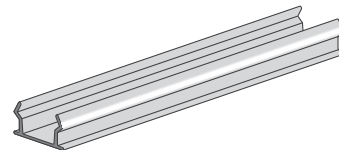

**Material:** Plastic

**Stock Length:** 10 ft.

**Use With:** All 1<sup>5</sup>/<sub>8</sub>" channel and inserts to prevent concrete seepage

Weight/100 pcs: 47 lbs.

**PS 3700 - Concrete Deck Insert**

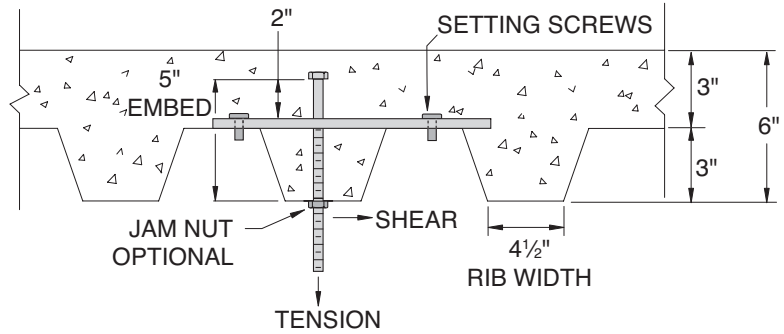
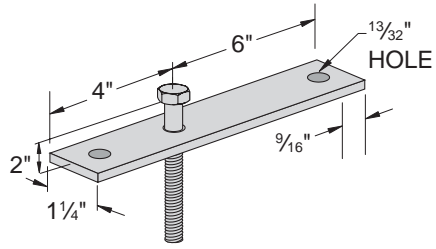

Part No.	Tension Load Rating/Lbs	Shear Load Rating/Lbs	Wt./100 pcs
PS 3700-3/8"	850	600	89
PS 3700-1/2"	1,380	1,000	111
PS 3700-3/8"	1,920	1,760	141

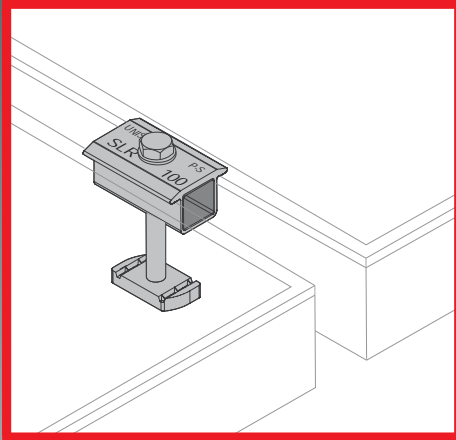

## SOLAR COMPONENTS

*Power-Strut® represents a line of steel, aluminum, and fiberglass strut and accessories used extensively in electrical infrastructure support.*

*Power-Strut is available in a range of corrosion inhibiting finishes making it a prime choice in today's marketplace. The Power-Strut system is infinitely adjustable for a multitude of configurations and uses.*

*The solar components shown in this section allow you to shape an effective solution for mounting solar panels that fits your exact needs.*

## Typical Solar Installation

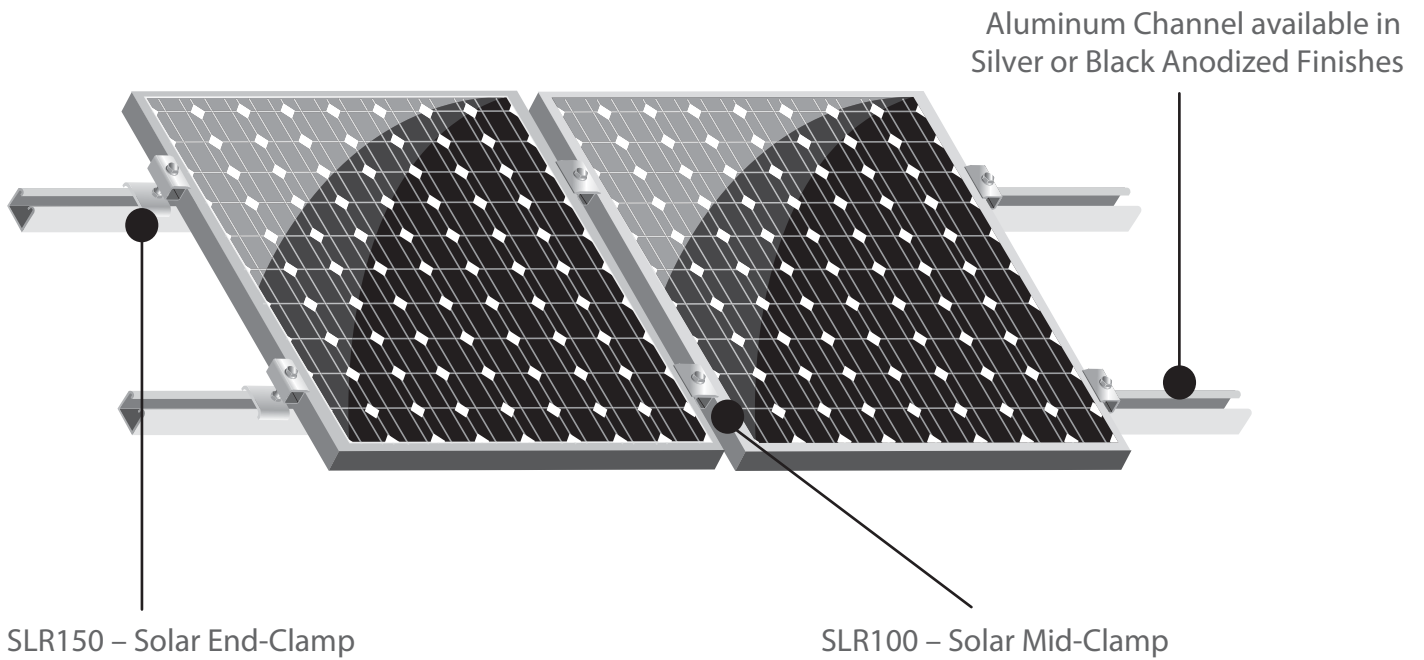

**SLR150 - \*Solar End Clamp**

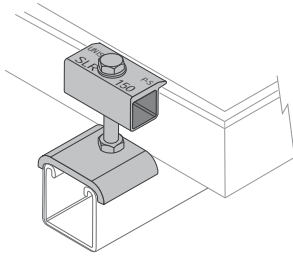

- End-clamp design for use with strut based **racking system**
- Patent-pending end-stop feature allows use with vertical strut
- Meets uplift loads of 350 lbs.
- \*Patent-pending

**SLR100 - Solar Mid-Clamp**

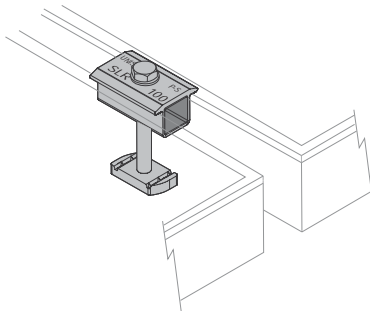

- Mid-clamp design for use with strut based racking system
- Provides .8”(21 mm) panel spacing
- Meets spacing requirements of WEEB-WMC
- Meets uplift loads of 350 lbs.

**WEEB - WMC - Electrical Equipment Bonding Washer**

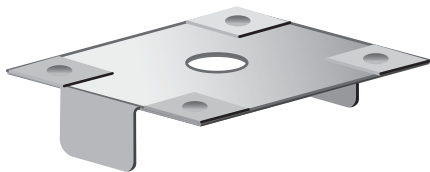

- Patented design features stainless steel teeth that pierce into anodized aluminum, providing a gas tight connection which prevents oxidation
- Meets ANSI/UL467 requirements for bonding/grounding systems
- Quick installation that is safe, reliable and consistent

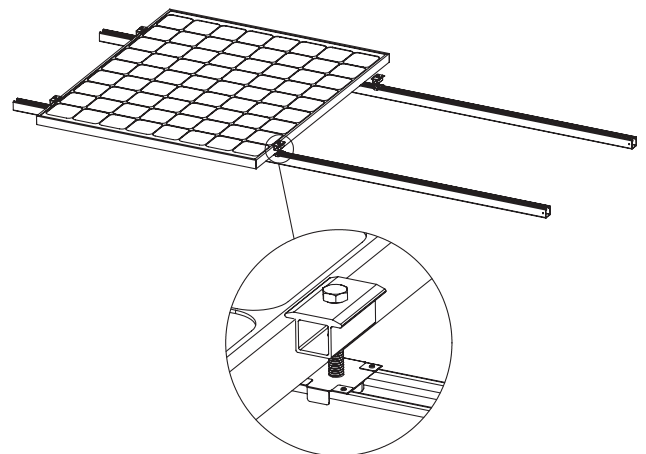



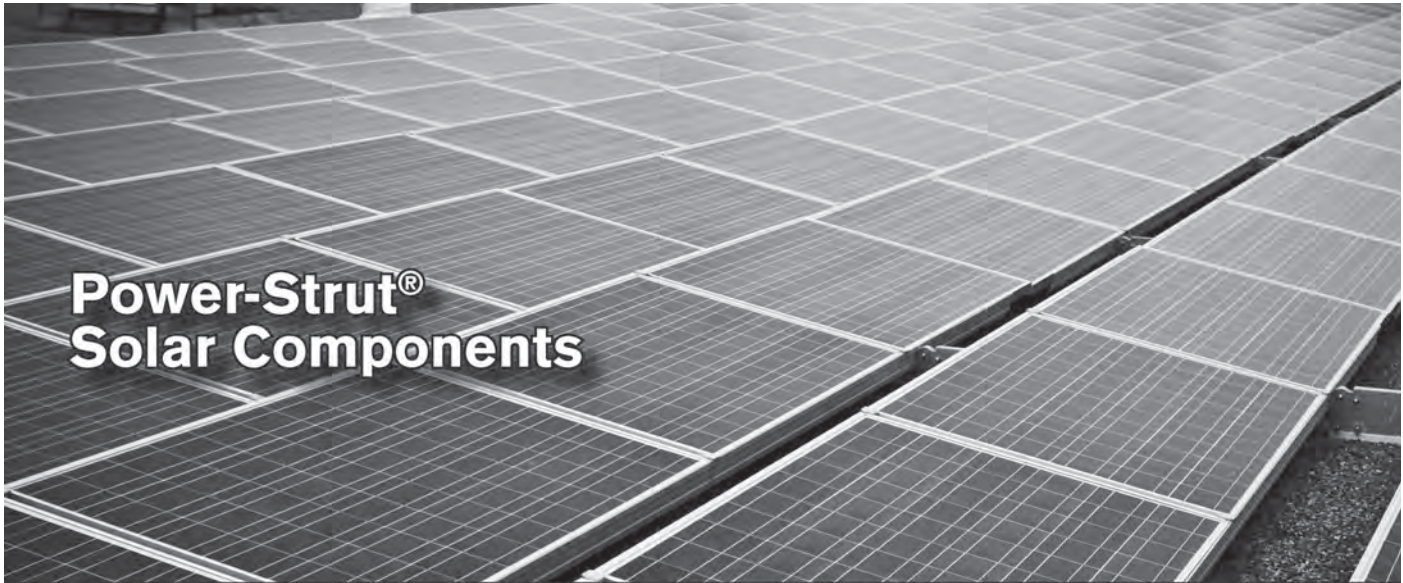

---

## KEY ADVANTAGES

- The market's only specific panel mounting components made exclusively for use with Power-Strut.
- Simple design used by the industry for a variety of installation methods and applications.
- Stainless steel hardware included with all solar clamps.
- Available in Black or Silver Anodized (Material AA-6063-T6) for corrosion protection and sleek appearance.
- Best fit with Power-Strut channel to create less penetration, and superior slip resistance.
- Available and supported by Power-Strut's national network of distributors.

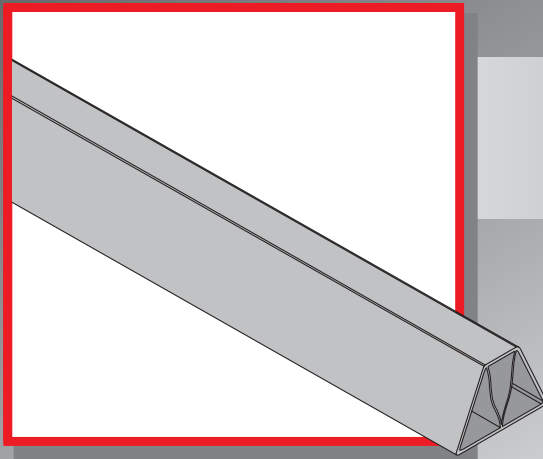

**UNIPIER®**

*Pipe supports to support roof mounted gas pipes, electrical conduit, solar piping and other mechanical piping. Unique design absorbs thermal expansion and contraction of pipes thus preventing damage to the roof membrane.*

**MATERIAL:**

Support Base is made of polycarbonate resin or hot-dipped galvanized or stainless steel as indicated for the specific base. The base is gently rounded to prevent gouging the roof membrane. Carbon black is added to the polycarbonate resin for UV resistance and protection.

Pipe Roller is made of polycarbonate, or steel as indicated for the specific part.

Other Metal Parts are made of hot-dipped galvanized or stainless steel.

Duct Supports are made of hot-dipped galvanized Power-Strut channel

# UNIPIER® - Sleeper Support



## RSS4 - Rooftop Sleeper Support

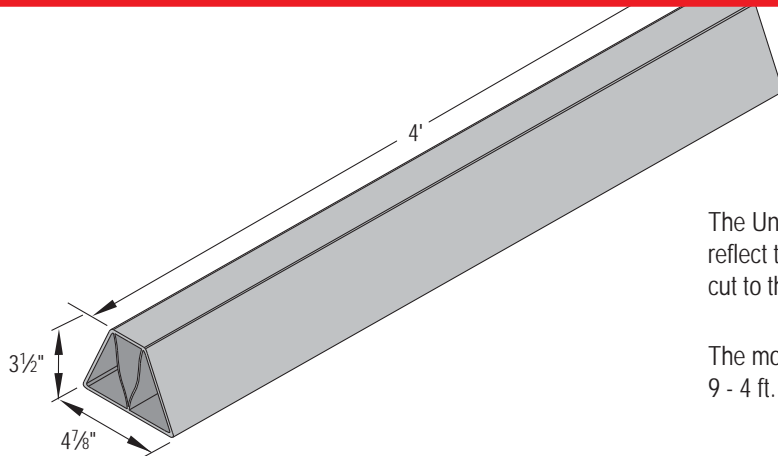

The Unipier rooftop sleeper is the first rooftop support that is white to reflect the sun's UV rays. It is cost-effective, lightweight and can be cut to the desired length while on the job site.

The model RSS4 is conveniently packaged in shrink wrap bundles of 9 - 4 ft. supports that can be easily carried to the rooftop.

The Unipier sleeper support is lightweight, just 4 lbs./4 ft. section, so it is easily transported to the job site in bundles of 9 supports.

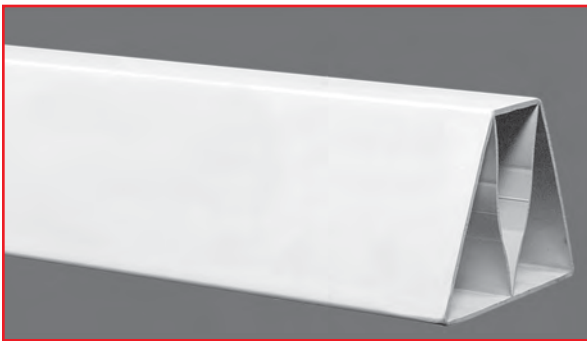

The Unipier sleeper support can be conveniently cut to lengths of 6" or longer right on the job site.



TEK screws or other self tapping fasteners are used to attach conduit supports, pipe clamps or other clamping fittings.

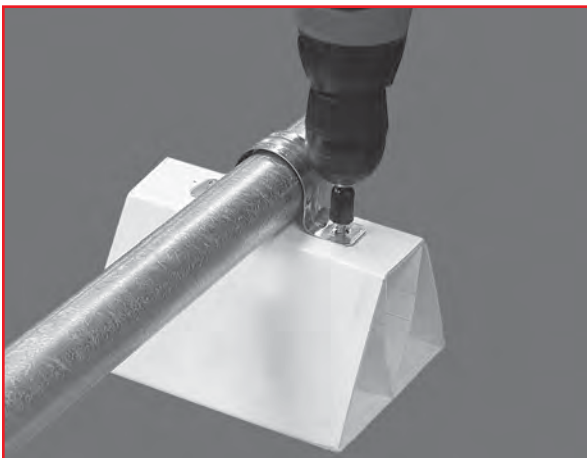

NOTE: Load not to exceed 50 lbs./6" length  
Part Number: RSS4

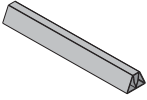

The Sleeper Support is not restricted to just pipe clamps. It makes a perfect companion for the Roofwalk<sup>®</sup> Rooftop Walkways.



Position the grating on the Unipier sleeper support and insert the appropriate size hold down clip (G639, G607, or G620).

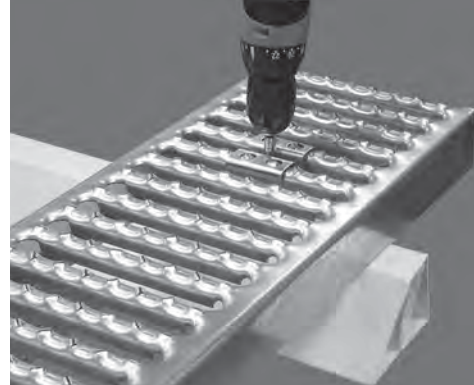

Use a TEK screw to attach the hold down clip.

***That's all that is required!***

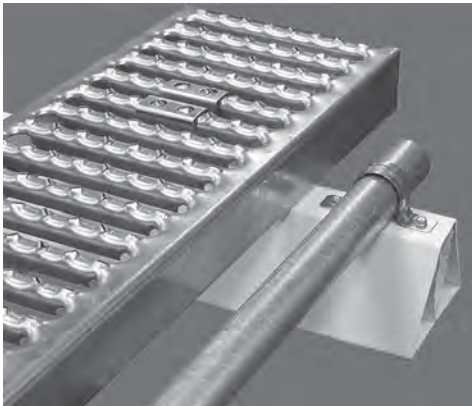

You can even use the Unipier support for multiple tasks. Here we have Unistrut Roofwalks<sup>®</sup> Rooftop Walkways and a piece of electrical conduit attached to the sleeper.

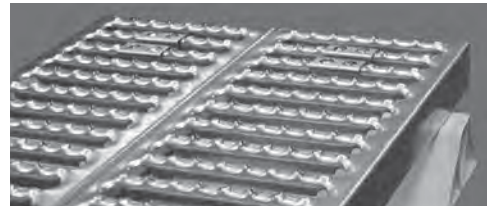

Grating can also be used to construct a platform for heavy equipment or even as a workstand.

## UP-SPSS Style Support



- Align Center hole of P4100T on base.
- Place square washer inside P4100T.
- Insert screw & torque to 19 ft./lbs.

Part Number	Qty. Unipier Bases	Supporting Channel	
		Qty.	Description
UP-BK	4	0	Base Only
UP-SPSS-6 HG	4	4	6" - P4100T HG (up to 3 1/2" Pipe)
UP-SPSS-10HG	4	4	10" - P4100T HG (4" to 8" Pipe)

**Note:**

1. The maximum uniform load on P1000T is 400 lbs.
2. Uniform load is limited by roof base allowed load of 200 lbs. (5 psi on roof).

**Single Pier Installation**

1. Align center hole of Unistrut P4100T on base and attach using supplied hardware. Torque screw to 19 ft./lbs.
2. Place pipe/tubing on P4100T and attach pipe/tubing clamp.

## UP-MPDS Style Support

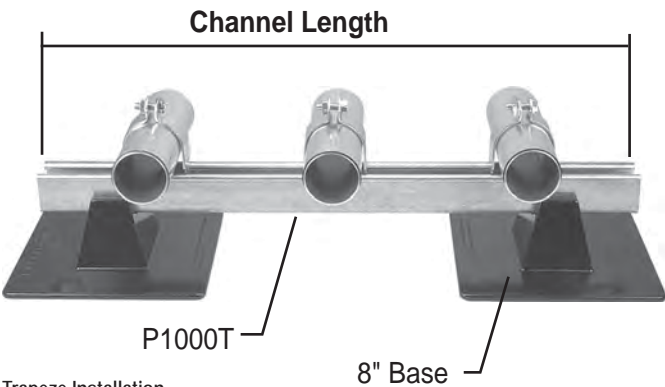

**Trapeze Installation**

1. Align end holes of Unistrut P1000T on bases and attach using supplied hardware. Torque screw to 19 ft./lbs.
2. Place pipe/tubing on support and attach with appropriate pipe/tubing clamp.

Part Number	Qty. Unipier Bases	Supporting Channel	
		Qty.	Description
UP-MPDS-26HG	4	2	26" - P1000T HG for Trapeze
UP-MPDS-38HG	4	2	38" - P1000T HG for Trapeze
UP-MPDS-50HG	4	2	50" - P1000T HG for Trapeze
UP-MPDS-62HG	4	2	62" - P1000T HG for Trapeze

**Note:**

1. The maximum uniform load on P1000T is 400 lbs.
2. Uniform load is limited by roof base allowed load of 200 lbs. (5 psi on roof).

**Note:** Kits do not include pipe/tubing or clamps.

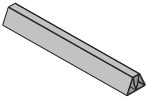

## Support Spacing

Pipe Size (Nom.)	Support Spacing			
	Sch. 40 Pipe Water-Filled <sup>(a)</sup>		Conduit GRC <sup>(b)</sup>	
	Single Pier	Trapeze <sup>(d)</sup>	Single Pier	Trapeze <sup>(d)</sup>
3/8"	7'	7'	N/A	N/A
1/2"	7'	7'	10'	10'
3/4"	7'	7'	10'	10'
1"	7'	7'	12'	12'
1 1/4"	7'	7'	14'	14'
1 1/2"	9'	9'	14'	14'
2"	10'	10'	16'	16'

Pipe Size (Nom.)	Support Spacing			
	Sch. 40 Pipe Water-Filled <sup>(a)</sup>		Conduit GRC <sup>(b)</sup>	
	Single Pier	Trapeze <sup>(d)</sup>	Single Pier	Trapeze <sup>(d)</sup>
2 1/2"	11'	11'	16'	16'
3"	12'	12'	13'(c)	20'
3 1/2"	13'	13'	11'(c)	20'
4"	12'(c)	14'	9'(c)	20'
5"	8'(c)	16'	6'(c)	20'
6"	6'(c)	17'	4'(c)	20'
8"	4'(c)	19'	N/A	N/A

**Note:**

- (a) Based on ANSI/MSS SP-69, 2003 Edition, Table 3.
- (b) Based on 2002 NEC, Table 344.30(B)(2).
- (c) Spacing limited to roof base allowed load of 200 lbs. (5 psi on roof).
- (d) Spacing may be limited by maximum allowed weight on trapeze to 400 lbs.

## Application Examples

Unipier Rooftop Support System provides a simple and versatile way to support and manage pipe, tubing, conduit, HVAC systems, and the like. The Unipier Rooftop Support System does not require roof surface penetration and allows the parts to remain off the surface.

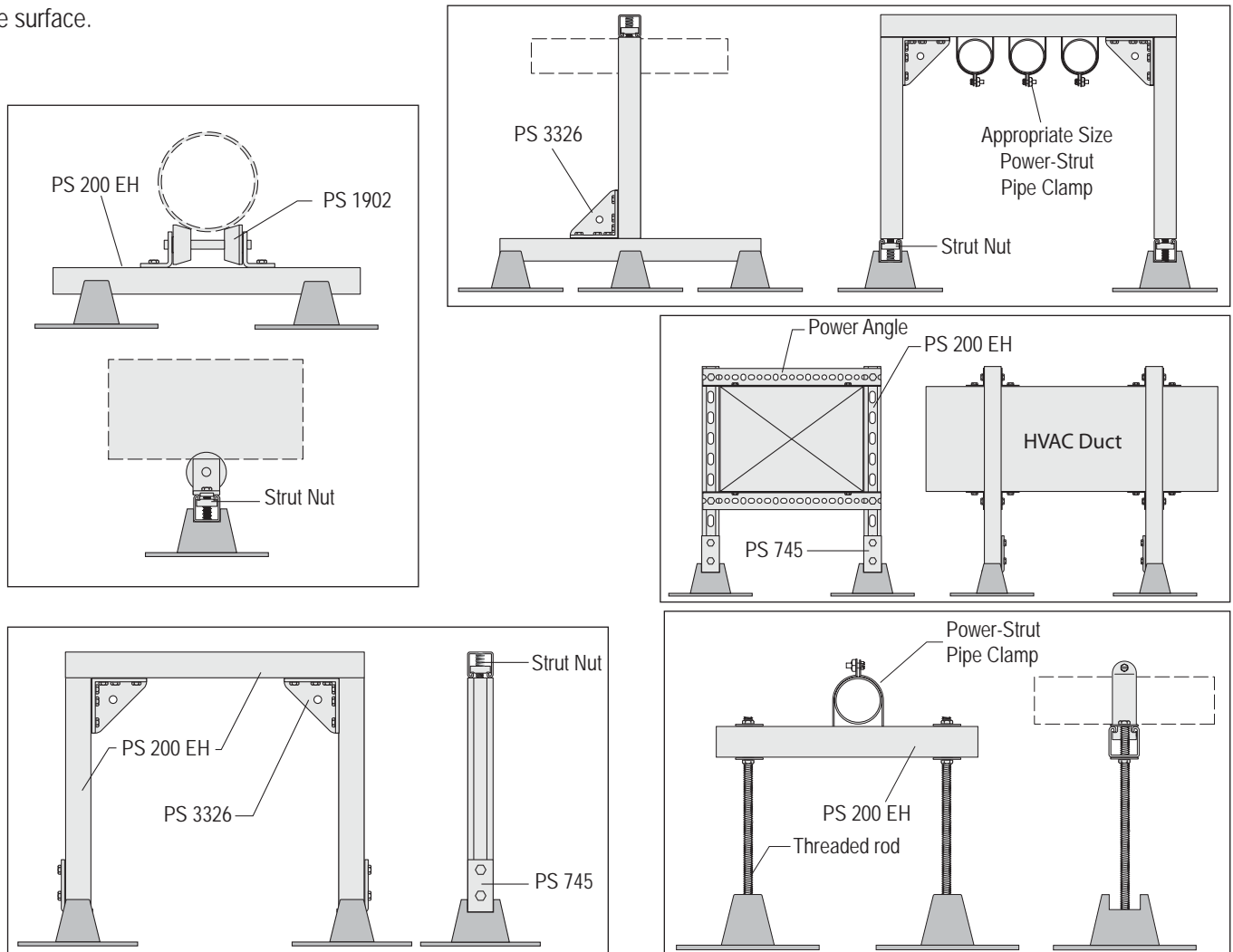

## 2.5-CS, 24-BS - Mounted Support, Polycarbonate Base

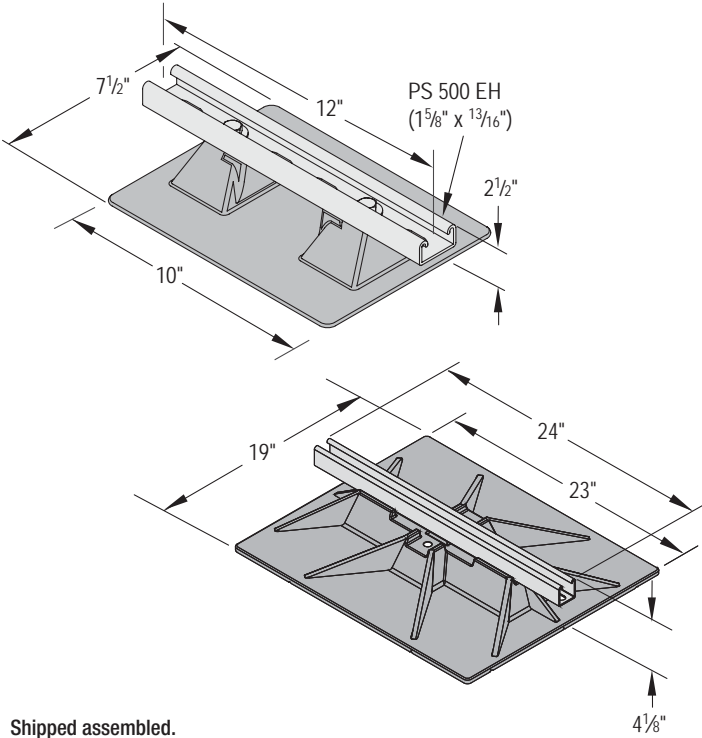

Shipped assembled.

Part Number	Material	Max. Uniform Load	Wt./Each
2.5-CS-2	Polycarbonate	100 lbs.	2.3 lbs.
24-BS-4	Polycarbonate	640 lbs.	8.0 lbs.

## Determining Maximum Pipe Size

Maximum pipe size supported by any of the strut supports is determined by the load and the clear space required between the pipes. The spacing between pipes should be as follows:

- 1" between piping 3" and smaller.
- 1 1/2" between a pipe 3" and smaller and a pipe 4" or larger.
- 2" between piping 4" and larger.
- At least 1" between pipe clamp and end of strut

For example, a support for two 3" pipes would require:  
 $1" + 3" + 1 1/2" + 3" + 1" = 9 1/2"$  wide channel support

## 2.5-CS, 16-BS thru 24-BS - Elevated Support, Polycarbonate Base

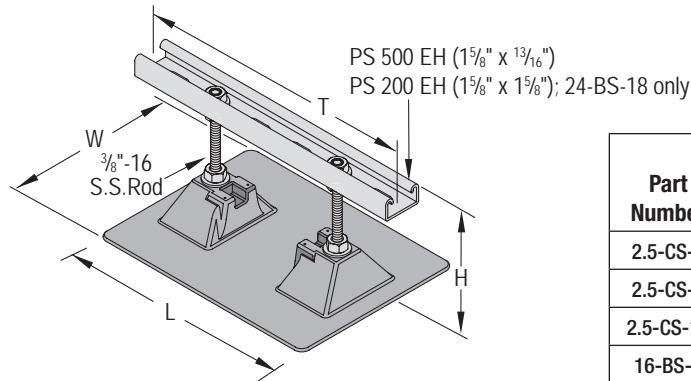

Note: Base for 2.5-CS-5, 2.5-CS-7 shown. Other bases have additional support or flanges to handle the increased loads.

All bases are polycarbonate material

Shipped assembled.

Part Number	"H" (max) in.	"W" in.	"L" in.	"T" in.	Max. Uniform Load	Wt./Each (lbs.)
2.5-CS-5	5"	7 1/2"	10"	12"	100 lbs.	2.1
2.5-CS-7	7 1/2"	7 1/2"	10"	12"	100 lbs.	2.5
2.5-CS-12	12"	9"	15 1/4"	12"	100 lbs.	4.0
16-BS-7	7"	9"	15 1/4"	16"	125 lbs.	5.0
16-BS-12	12"	9"	15 1/4"	16"	125 lbs.	8.0
20-BS-7	7"	16"	18"	20"	440 lbs.	10.8
20-BS-12	12"	16"	18"	20"	440 lbs.	15.1
24-BS-18	12"	23"	19"	24"	640 lbs.	8.0

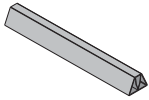

## 16-BS-7, 12-BS-7 - Elevated Support, Steel Base

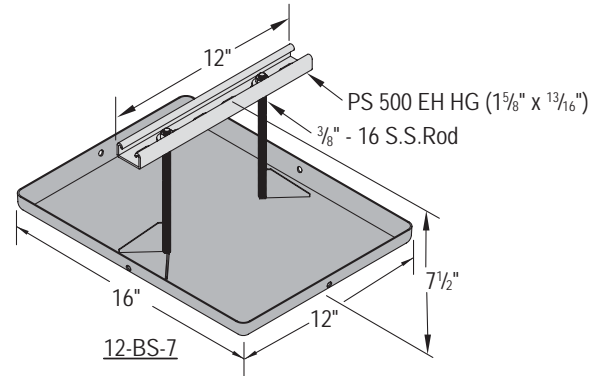
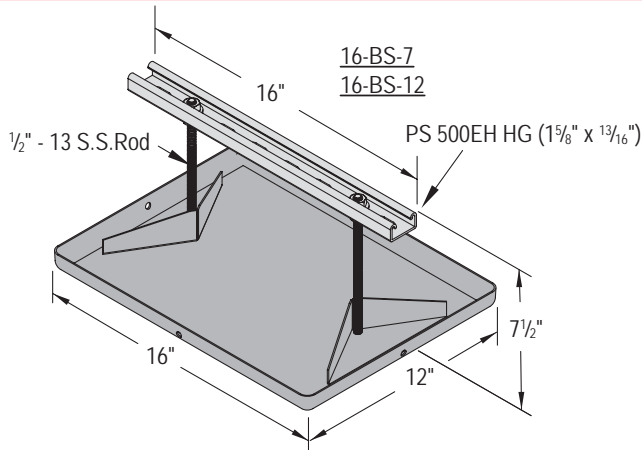

Shipped assembled.

Part Number	Base Material	Max. Uniform Load	Wt./Each
16-BS-7 HG	Hot-Dipped Galvanized	150 lbs.	7.5 lbs.
16-BS-7 SS	Stainless Steel	150 lbs.	7.5 lbs.

Part Number	Base Material	Max. Uniform Load	Wt./Each
12-BS-7 HG	Hot-Dipped Galvanized	150 lbs.	7.5 lbs.
12-BS-7 SS	Stainless Steel	150 lbs.	7.5 lbs.

## 1.5 Pipe Support - Mounted, Polycarbonate Base

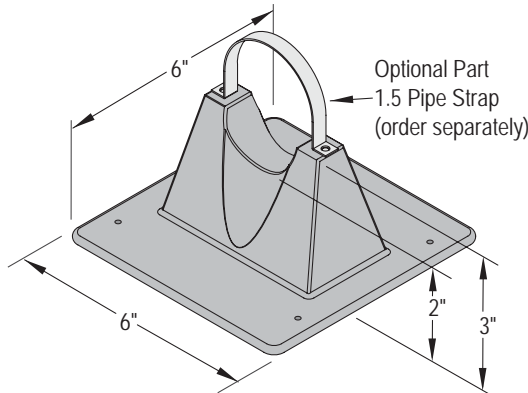

Part Number	Max. Pipe Capacity	Max. Uniform Load	Wt./Ea.	Optional Pipe Strap
1.5 Pipe Support	1 1/2" ID, 1.9" OD	80 lbs.	0.35 lbs.	1.5 Pipe Strap

Note: Base is polycarbonate

Optional pipe strap aluminum w/SS Screws

Shipped assembled.

## 3-R, 5-R - Mounted, with Roller, Polycarbonate Base

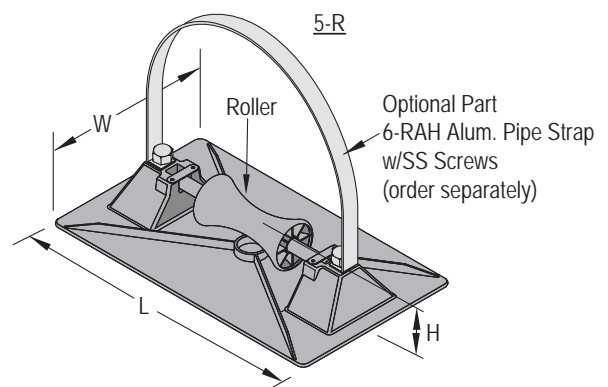
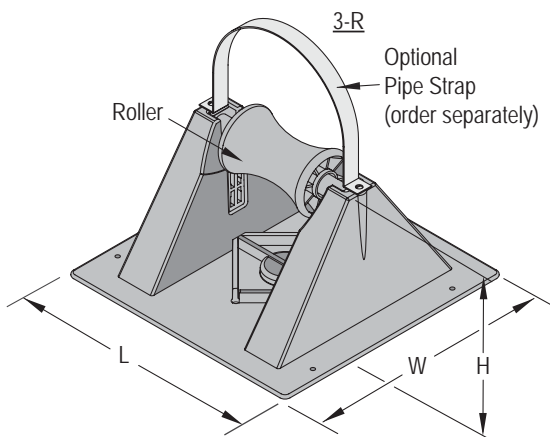

Note: All bases are polycarbonate. Optional pipe strap aluminum w/SS Screws

Part Number	"H" in.	"W" in.	"L" in.	Roller size	Max. Pipe Capacity	Max. Uniform Load	Wt./Ea. Lbs.	Optional Pipe Strap
3-R-2	2.15"	7 3/4"	7 3/4"	3"	3" ID - 3 3/4" OD	100 lbs.	1.1 lbs.	3-R-2 Pipe Strap
3-R-4	4"	7 3/4"	7 3/4"	3"	3" ID - 3 3/4" OD	100 lbs.	1.2 lbs.	3-R-4 Pipe Strap
5-R	2.35"	9"	15 1/4"	5"	5" ID - 6" OD	150 lbs.	2.4 lbs.	6-RAH Pipe Strap



## 3-RAH, 5-RAH, 6-RAH, 8-RAH – Elevated Support, with Roller, Polycarbonate Base

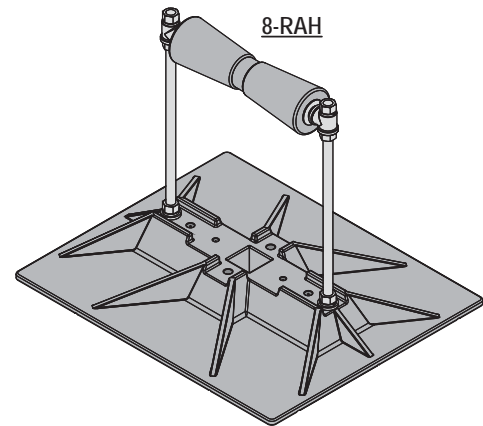
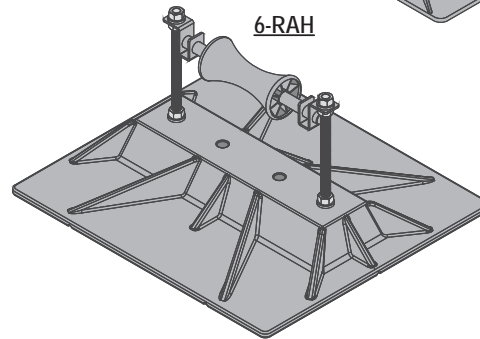
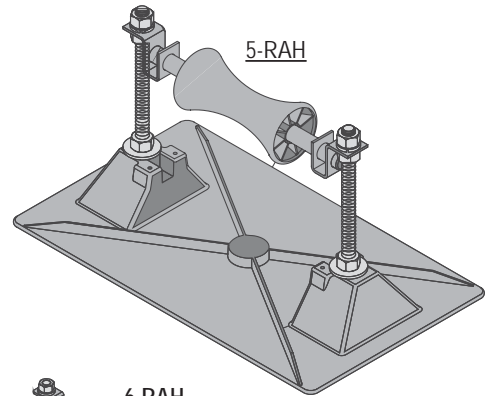
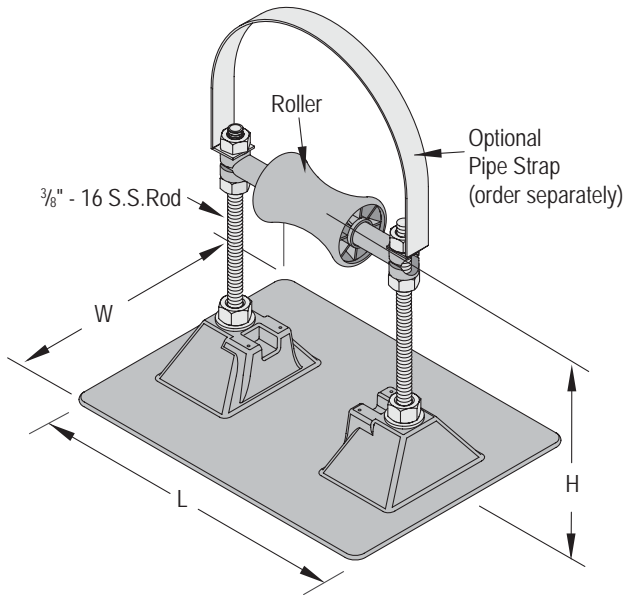

Note: Base for 3-RAH-7 shown. Other bases have additional support or flanges to handle the increased loads.

All bases are polycarbonate material

Optional pipe strap aluminum w/SS Screws

Shipped assembled.

Part Number	"H" (max) in.	"W" in.	"L" in.	Roller Size in.	Max. Pipe Capacity	Max. Uniform Load	Wt./Ea. Lbs.	Optional Pipe Strap
3-RAH-7	7"	7 1/2"	10"	3"	3" ID - 3 3/4" OD	100 lbs.	1.9	3-RAH Pipe Strap
3-RAH-12	12"	9"	15 1/4"	3"	3" ID - 3 3/4" OD	100 lbs.	5.8	3-RAH Pipe Strap
5-RAH-7	7"	9"	15 1/4"	5"	5" ID - 6" OD	150 lbs.	4.8	6-RAH Pipe Strap
5-RAH-12	12"	9"	15 1/4"	5"	5" ID - 6" OD	150 lbs.	4.8	6-RAH Pipe Strap
6-RAH-7	7 1/2"	16"	18"	5"	6" ID - 8 1/2" OD	250 lbs.	8.8	6-RAH Pipe Strap
6-RAH-12	12"	16"	18"	5"	6" ID, 8 1/2" OD	250 lbs.	9.8	6-RAH Pipe Strap
8-RAH-18	18"	19"	23"	12"	6" ID, 8 1/2" OD	640 lbs.	20.0	8-RAH Pipe Strap

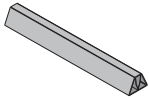

Metal Channel  
Fasteners  
Fittings  
Pipe & Conduit Clamps  
Electrical  
Concrete Inserts  
Solar Components  
Unipier®  
Jr. Channel  
Power-Angle  
Fiberglass  
Tech. Data

## 3-RAH-7, 4-RAH-7 – Elevated Support, with Roller, Steel Base

Shipped assembled.

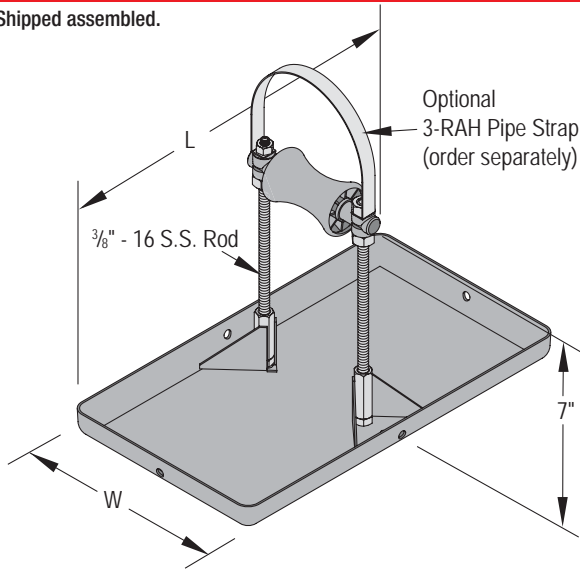

Part Number	"W" in.	"L" in.	Roller in.	Material	Max. Pipe Capacity	Max. Uniform Load	Wt. Each Lbs
3-RAH-7 HG	8"	14"	3"	Hot-Dipped Galvanized	3" ID 3 3/4" OD	100 lbs.	3.3
3-RAH-7 SS	8"	14"	3"	Stainless Steel	3" ID 3 3/4" OD	100 lbs.	3.3
4-RAH-7 HG	12.07"	16.07"	5"	Hot-Dipped Galvanized	4" ID 5" OD	150 lbs.	6.8
4-RAH-7 SS	12.07"	16.07"	5"	Stainless Steel	4" ID 5" OD	150 lbs.	5.8

Note: Optional 3-RAH Pipe Strap aluminum w/SS Screws

## 1.5 Spacer, 3-R Spacer – Spacer for Model 1.5 and Model 3-R

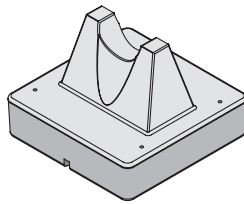
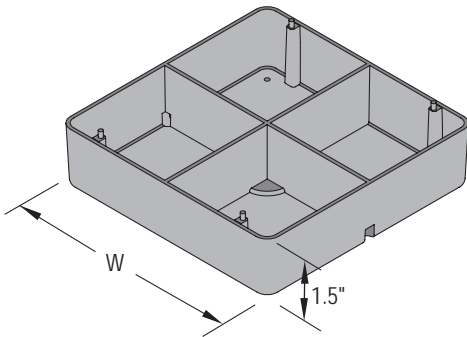

Example: Spacer with Model 1.5

Part Number	Use With	"W"	Added Pipe Clearance	Wt./Ea.
1.5 Spacer	1.5	6"	1 1/2"	0.43 lbs
3-R Spacer	3-R-2 or 3-R-4	7-1/2"	2"	0.75 lbs

Material: Polycarbonate

## Support Pad – Polycarbonate Deck Plate

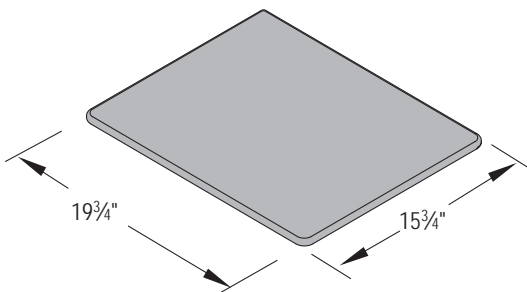

## Deck Plate – Stainless Steel Deck Plate

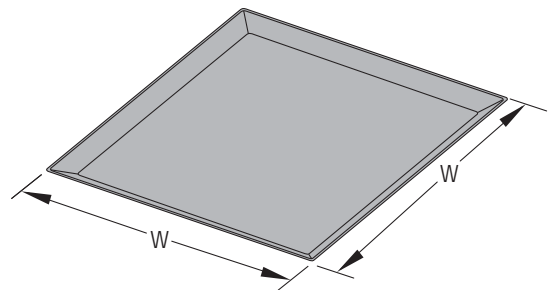

The Unipier support pad is designed to provide a barrier between the roof membrane and rooftop equipment. The support pad is 1/8" thick and are compatible with all current types of decking and commonly used built-up and single-ply roof membranes.

Support pads should be installed in the following areas:

- Under all Unipier pipe supports. The pipe support must be placed evenly over the support pad.
- In high traffic points or where regular maintenance is necessary to service rooftop equipment.

When installing the support pad, remove all rock, aggregate, dirt and excess dust from an area of the roof membrane slightly larger than the support pad. Then, apply the support pad on the cleaned area and center the Unipier pipe support on the rooftop pad.

The maximum roof top load should not exceed 5 p.s.i. The rooftop pad can withstand higher loading, but the roof membrane and insulation are typically limited to 5 p.s.i.

Part Number	Material	Width "W"	Wt./Each
Deck Plates 12 SS	Stainless Steel	12"	2.0 lbs.
Deck Plates 18 SS	Stainless Steel	18"	4.5 lbs.

Model 6-H, Model 8-H-DB, Model 16-H - Polycarbonate Base

**Model 6-H Base P**

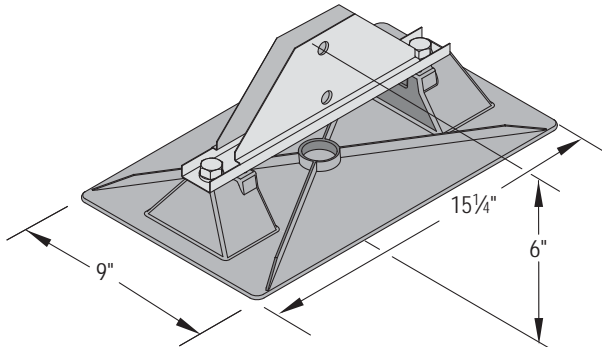

Note: Maximum 150 lbs. Load  
Wt./Ea.: 2.5 lbs.

**Model 8-H-DB Base P**

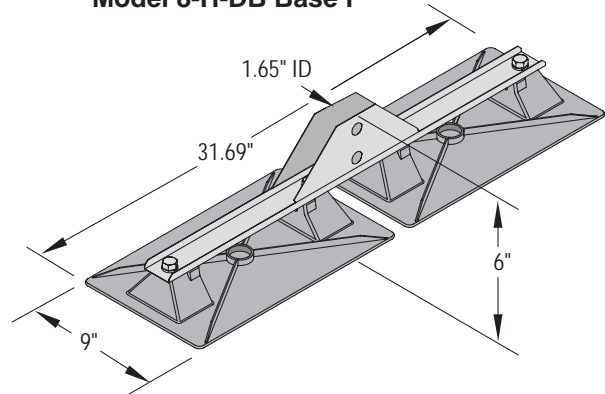

Note: Maximum 350 lbs. Load  
Wt./Ea.: 4.5 lbs.

**Model 16-H Base P**

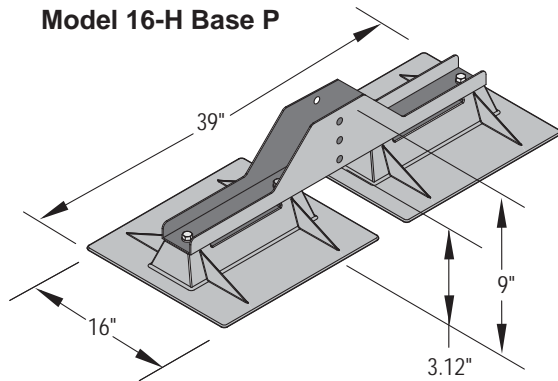

Note: Maximum 350 lbs. Load  
Wt./Ea.: 18.5 lbs.

6-H Base, 8-H Base, 16-H Base - Steel Base

**Model 6-H, 8-H, 16-H Base HG or S.S.**

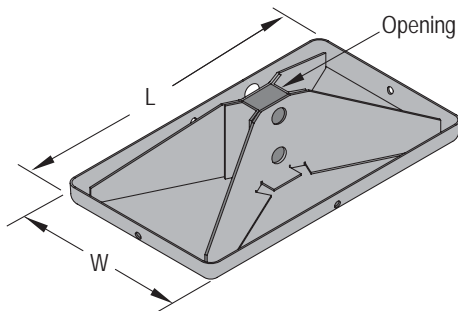

Part Number	"W"	"L"	"Opening"
6-H Base HG	8"	14"	1-5/8" x 7/8"
6-H Base SS	8"	14"	1-5/8" x 7/8"
8-H Base HG	16"	12"	1-5/8" x 1-5/8"
8-H Base SS	16"	12"	1-5/8" x 1-5/8"
16-H Base HG	20"	20"	3" x 3"
16-H Base SS	20"	20"	3" x 3"

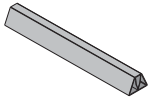

## Custom Fabrication

The Unipier products offer a great deal of flexibility. If you do not find an "off-the-shelf" support for your particular application, contact Unistrut with your requirements. We can design and build the proper support for your unique application.

Samples of typical custom fabrications are shown in this section of the catalog.

Custom products are shown on the following pages. For a quotation on custom fabrication, contact Unistrut with the parameters for your design as shown below.

### Pipe Stands

1. Quantity of supports required (or total footage of pipe)
2. Type of pipe
3. Size of pipe and number of pipes per support
4. Pipe contents
5. Clearance height above roof
6. Thickness of any insulation around pipe

### Duct and Cable Tray Supports

1. Dimension of duct
2. Clearance height above roof
3. Total footage of duct
4. Thickness of insulation, if any

### Unistrut Roofwalks® Rooftop Walkways, Crossover, Ramp and Platforms

1. Width and length desired
2. Height off roof
3. Specify if railing is needed
4. Type of roof

### Mechanical Supports

1. Width and length desired
2. Height off roof
3. Weight of unit

## 2.5-SB-H, 5-SB-H, 8-SB-H, 8-SB-HD – Single Base Trapeze

Model	Material	Max. Uniform Load Per Pipe Stand
2.5-SB-H (shown)	Polycarbonate	125 lbs.
5-SB-H	Polycarbonate	250 lbs.
5-SB-H HG	Hot-Dipped Galvanized	170 lbs.
8-SB-H	Polycarbonate	296 lbs.
8-SB-HD	Polycarbonate	640 lbs.

**Note:** For maximum pipe size, refer to note on page 120.

# UNIPIER® - Fabricated Support



## 6-H, 8-H, 10-H, 16-H – Double Base Trapeze

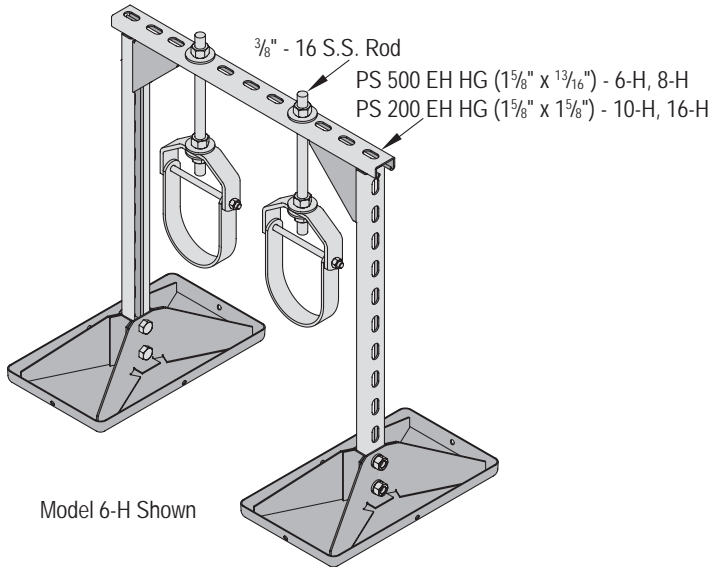

Model 6-H Shown

Model	Material	Max. Uniform Load Per Pipe Stand	Max. Pipe Capacity
6-H-P	Polycarbonate	300 lbs.	7 1/2"
8-H-P	Polycarbonate	700 lbs.	9"
6-H-HG	Hot-Dipped Galvanized	300 lbs.	7 1/2"
6-H-SS	Stainless Steel	300 lbs.	7 1/2"
8-H-HG	Hot-Dipped Galvanized	700 lbs.	9"
8-H-SS	Stainless Steel	700 lbs.	9"
10-H-P	Polycarbonate	1,600 lbs.	9"
16-H-HG	Hot-Dipped Galvanized	1,600 lbs.	18"
16-H-SS	Stainless Steel	1,600 lbs.	18"

## 8-H-DB, 16-H-DB – Heavy Duty Double Base Trapeze

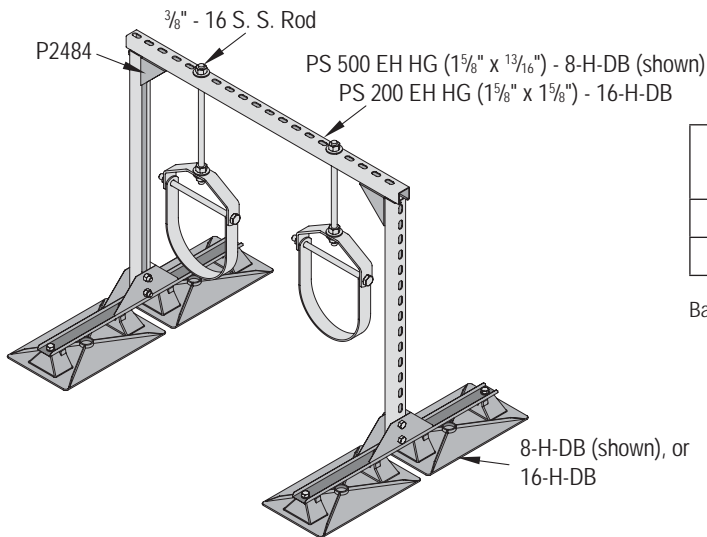

Model	Max. Uniform Load Per Pipe Stand	Max. Pipe Capacity
8-H-DB	700 lbs.	9"
16-H-DB	1,600 lbs.	18"

Base Material: Polycarbonate

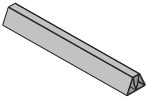

## 6-DSA, 8-DSA – Double Base Duct Support

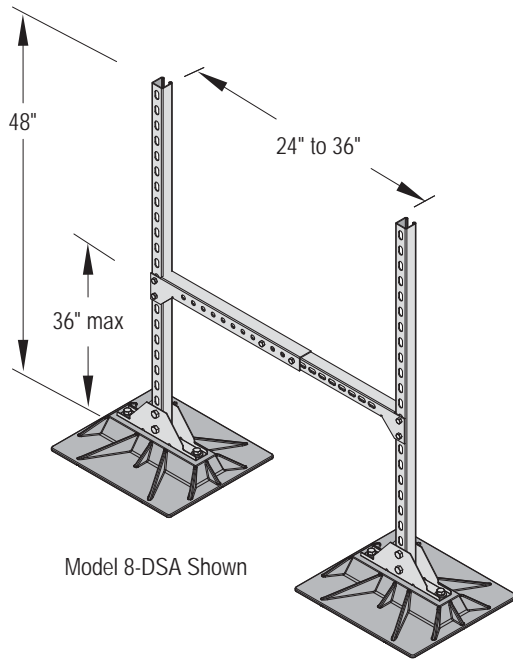

Model	Material	Max. Uniform Load Per Duct
6-DSA	Polycarbonate	150 lbs.
8-DSA	Polycarbonate	300 lbs.

## 6-DS, 8-DS, 8-DS-DB, 10-DS – Double Base Duct Support

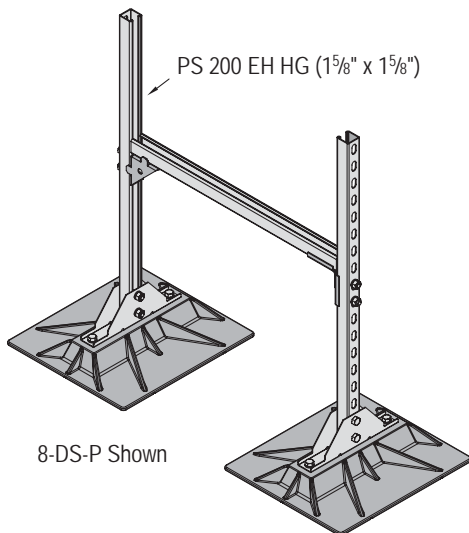

Model	Material	Max. Uniform Load Per Duct
6-DS-P	Polycarbonate	150 lbs.
6-DS-HG	Hot-Dipped Galvanized	300 lbs.
6-DS-SS	Stainless Steel	300 lbs.
8-DS-P	Polycarbonate	300 lbs.
8-DS-HG	Hot-Dipped Galvanized	300 lbs.
8-DS-SS	Stainless Steel	300 lbs.
8-DS-DB-P	Polycarbonate	300 lbs.
10-DS-P	Polycarbonate	300 lbs.

# UNIPIER® - Fabricated Support



## Heavy Duty Mechanical Support

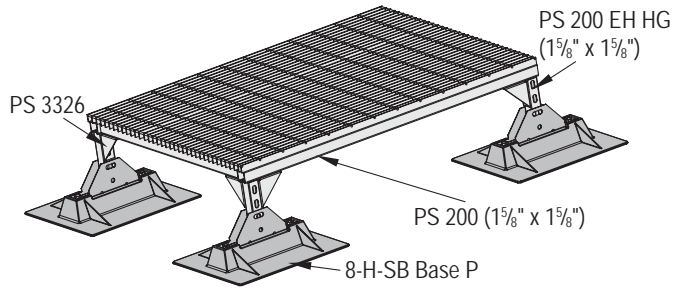

## Light Duty Mechanical Support

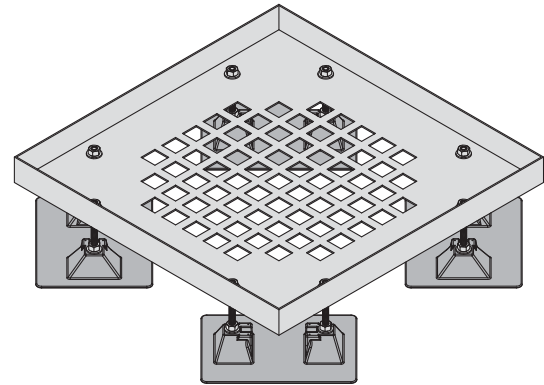

Note: Adjustable height, maximum load 200 lbs.  
Available Sizes: 18" x 18", 24" x 24", 30" x 30", 36" x 36"  
Note: Custom sizes available, Contact Unistrut for information.

## Bridge Cross-Over, Walkway, Service Platform or Ramp

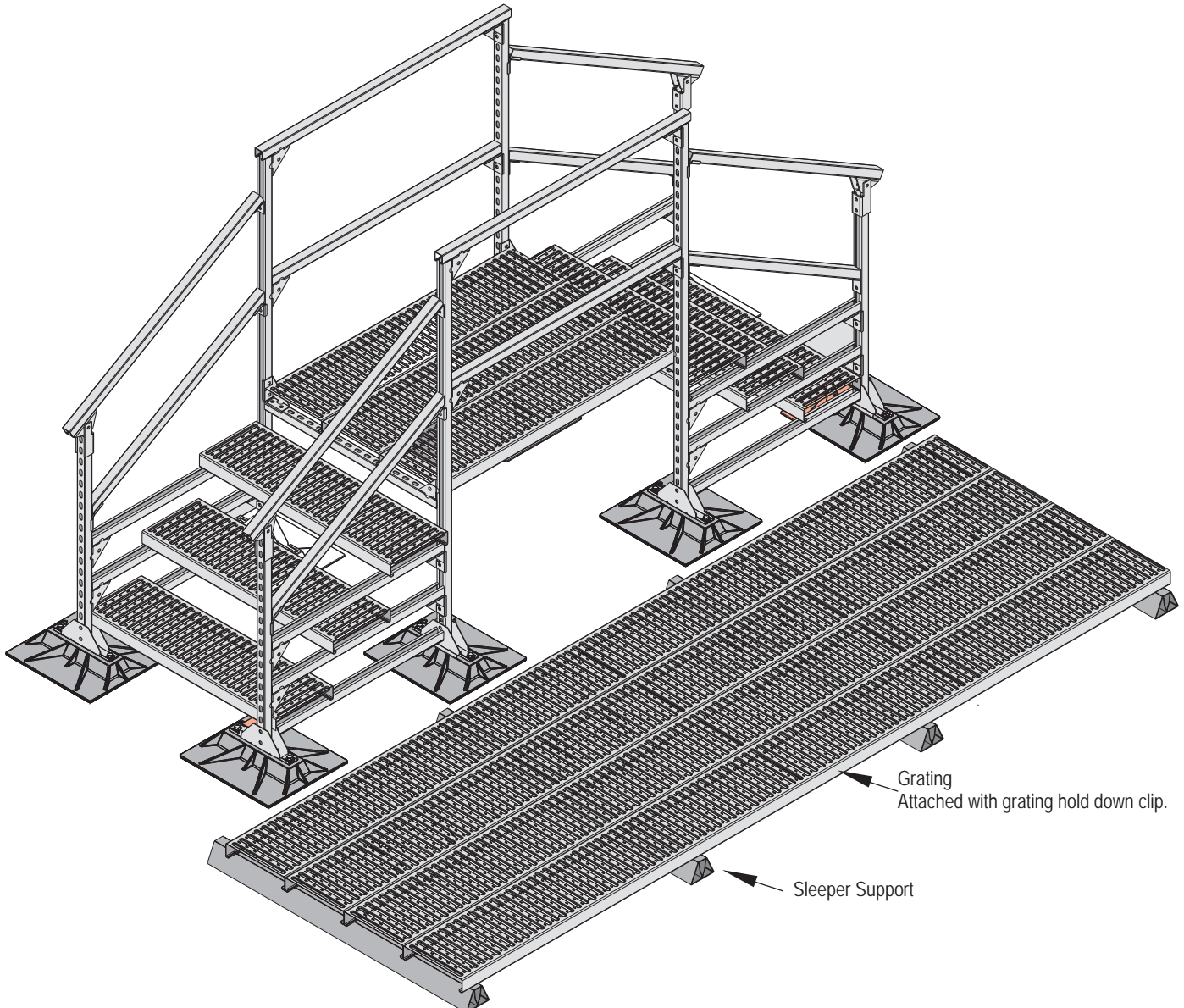

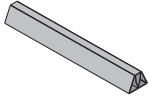

## Product Description:

A pipe support used to support roof mounted gas pipes, electrical conduit, solar piping and other mechanical piping. Unique design absorbs thermal expansion and contraction of pipes thus preventing damage to the roof membrane. Pipes rests include:

- "U" shaped cradle situated in a polycarbonate resin seat.
- Self-lubricating roller polycarbonate resin rod and roller. As daytime temperatures warm the roof membrane and the mechanical pipe network found on the roof, causing them to expand, the roller bearing in the pipe stand rolls beneath the pipe it supports. A difference between night and day temperatures of 20° F. causes 100 ft. of 1" steel pipe to move as much as 1/4".
- A strut system constructed of hot-dipped galvanized steel components including clevis hangers or band hangers.
- For the duct supports, the ducts rest on a 1 5/8" x 1 5/8" or 1 5/8" x 7/8" Unistrut channel and are adjustable in height.

## Composition and Material:

**Support base** is made of polycarbonate resin or hot-dipped galvanized or stainless steel as indicated for the specific base. The base is gently rounded to prevent gouging the roof membrane. Carbon black is added to the polycarbonate resin for UV resistance and protection.

**Pipe Roller** is made of polycarbonate, or steel as indicated for the specific part.

**Other Metal Parts** are made of hot-dipped galvanized or stainless steel.

**Duct Supports** are made of hot-dipped galvanized Unistrut channel

**All-Thread Rod** are 1/2" or 3/8" stainless steel and are used for vertical supports.

## Compatibility:

Pillow Block Pipe Stands are recommended for use on and compatible with all current types of decking and with all commonly used built-up and single-ply roofing membranes where roof-mounted pipes occur. For heavier loads it is prudent to use a Unipier Support Pad or other traffic pad to further protect the roof membrane.

## Adjustable Height:

Several models allow adjustable height as desired or required by the code or roof system. Each model can be configured to allow plus or minus height above the roof. Purchasers should specify desired heights upon ordering the pillow block hangers.

## Installation Process:

1. Center the support beneath the pipes or ducts so that the pipe or ducts are squarely over the pipe stand.
2. For adjustable models, adjust the support to the desired height and to ensure a uniform load with other supports. Make certain the horizontal support strut is level.
3. Place the pipe or duct on the support without dropping or causing undue impact.

For heavier loads it is prudent to install an additional sheet of roofing material, a Unipier Deck Plate, or Unipier Support Pad beneath the duct support.

For built-up roofs, all loose aggregate from an area 2" larger than each base should be removed from the area directly beneath the support. Care should be taken to install each support so it supports a proportional and equal amount of weight at each support.

## Optional Straps:

For many of the models, the pipe may be secured to the pipe stand by using optional Unipier Pipe Straps.

## Note:

When using a pipe strap, allow sufficient room between the pipe and the strap to allow free movement of the pipe without binding.

## Loads and Spacing:

Unistrut recommends that spacing not exceed 10' between centers depending upon the load. Make certain each pipe stand is properly elevated to ensure a uniform load weight at all pipe stands and not exceed the load specified for the particular model support. All loads given in this catalog are for uniformly distributed loads.

## Maintenance:

Normally maintenance is not required. Semi-annual inspection is required to check pipe stand position and set pipe alignment, weight distribution and improper installation which may cause pipe stand damage or failure.



## Typical Steel Pipe Weights – Pipe Standing Load

For Schedule 40 Steel Pipe. (ASTM A53-86)

Pipe Size	Pounds per Foot of Pipe Empty	Pounds per Foot Containing Gas	PSI per Foot on Model 6-RAH-7 BASE	5 Feet Spacing	7.5 Feet Spacing	10 Feet Spacing
		Pounds per Foot Containing Water				
3"	7.575	7.578	.02	37.89 lbs. .13 psi	56.84 lbs. .20 psi	75.78 lbs. .26 psi
		13.4	.04	67.00 lbs. .23 psi	100.50 lbs. .35 psi	134.00 lbs. .47 psi
4"	10.790	10.794	.03	53.97 lbs. .19 psi	80.96 lbs. .28 psi	107.94 lbs. .37 psi
		16.3	.05	81.50 lbs. .28 psi	122.25 lbs. .42 psi	163.00 lbs. .57 psi
5"	14.620	14.627	.04	73.14 lbs. .25 psi	109.7 lbs. .38 psi	146.27 lbs. .51 psi
		23.2	.07	116.00 lbs. .40 psi	174.00 lbs. .60 psi	232.00 lbs. .80 psi
6"	18.970	18.98	.05	94.49 lbs. .33 psi	142.35 lbs. .49 psi	189.80 lbs. .66 psi
		31.5	.09	157.50 lbs. .55 psi	236.25 lbs. .82 psi	315.00 lbs. 1.09 psi
8"	28.55	28.567	.08	142.84 lbs. .50 psi	214.25 lbs. .74 psi	285.67 lbs. .99 psi
		50.1	.14	250.00 lbs. .87 psi	375.75 lbs. 1.30 psi	501.00 lbs. 1.74 psi
10"	40.48	40.507	.12	202.54 lbs. .70 psi	303.80 lbs. 1.05 psi	405.07 lbs. 1.41 psi
		74.6	.21	373.00 lbs. 1.30 psi	559.50 lbs. 1.94 psi	746.00 lbs. 2.60 psi

PSI is in pounds per square inch on models 6-RAH-7 BASE, which contain 2 bases for a total of 288 square inches of roof contact area support.

## Chart of Usual Pipe Diameters

Pipe	PVC (Steel Size)	PVC (C900)	Cast Iron	Steel	Conduit
Inside Diameter	Outside Diameter	Outside Diameter	Outside Diameter	Outside Diameter	Outside Diameter
½"	.84"	–	–	.84"	.840"
¾"	1.05"	–	–	1.05"	1.050"
1"	1.32"	–	–	1.32"	1.315"
1 ¼"	1.66"	–	–	1.66"	1.660"
1 ½"	1.90"	–	–	1.90"	1.90"
2"	2.38"	2.50"	2.50"	2.38"	2.375"
2 ½"	2.88"	–	–	2.88"	2.875"
3"	3.50"	–	3.96"	3.50"	3.500"
3 ½"	–	–	–	–	4.000"
4"	4.50"	4.80"	5.00"	4.50"	4.500"
5"	–	–	–	5.56"	5.563"
6"	6.63"	6.90"	7.22"	6.63"	6.625"
8"	8.63"	9.05"	9.42"	8.63"	–
10"	10.75"	11.10"	11.60"	10.75"	–

The above dimensions are for usual and customary pipe sizes. Actual pipe sizes may vary from manufacturer to manufacturer.

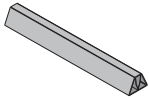

## Unipier Specifications for Typical Bases

Base Model	Outside Dimension at Roof Contact (in.)	Roof Contact Area (in. <sup>2</sup> )	Allowable Loading in Pounds	PSI on Roof for Each Base Under Maximum Load	Composition of Material of Base
1.5	6 X 6	24.42	80	3.27	P
1.5 SPACER	6 X 6	33.06	80	2.41	P
2.5-CS-2, 2.5-CS-5, 2.5-CS-7	7.5 X 10	57.50	100	1.73	P
2.5-CS-12	9 X 15.25	111.75	100	0.89	P
2.5-SB-H P	9 X 15.25	111.75	125	1.11	P
3-R-2; 3-R-4	7.75 X 7.75	39.64	100	2.52	P
3-R SPACER	7.25 X 7.25	52.56	100	1.90	P
3-RAH-7	7.5 X 10	57.50	100	1.73	P
3-RAH-12	9 X 15.25	111.75	100	1.11	P
3-RAH-7 HG / SS	8 X 14	96.06	100	1.04	HG / SS
4-RAH-7 HG / SS	12 X 16	174.89	150	0.85	HG / SS
5-R; 5-RAH-7; 5-RAH-12	9 X 15.25	111.75	150	1.34	P
5-SB-H HG	12 X 16	174.89	170	0.97	HG / SS
5-SB-H P	16 X 18	220.32	250	1.13	P
6-RAH-7; 6-RAH-12	16 X 18	220.32	250	1.13	P
6-RAH-7 HG/SS; 6-RAH-RS HG/SS	12 X 16	174.89	150	0.85	HG / SS
6-H-P (used in pairs)	9 X 15.25	223.50	310	1.38	P
6-H (2 Bases) HG / SS	8 X 14	192.12	310	1.61	HG / SS
8-H-SB-P (used in pairs)	16 X 18	440.64	700	1.58	P
8-H-DB-P (used in pairs)	9 X 31.69	447.00	700	1.56	P
8-H HG / SS (used in pairs)	12 X 16	349.78	700	2.00	HG / SS
8-RAH-18	19 x 23	325.98	640	1.96	P
8-SB-H	19 x 23	325.98	640	1.96	P
10-H-DS P	19 x 23	325.98	640	1.96	P
12-BS-7 HG / SS	12 X 16	174.89	150	0.85	HG / SS
16-BS-7; 16-BS-12	9 X 15.25	111.75	125	1.11	P
16-BS-7 HG / SS	12 X 16	174.89	150	0.85	HG / SS
16-H-P (used in pairs)	16 X 39	881.28	1600	1.81	P
16-H HG / SS (used in pairs)	20 X 20	800.00	1600	2.00	HG / SS
20-BS-7; 20-BS-12	16 X 18	220.32	250	1.13	P
24-BS-4; 24-BS-18	19 x 23	325.98	640	1.96	P

P – Polycarbonate Resin, SS – Stainless Steel - ASTM No. 304, HG – Hot-Dipped Galvanized

**Note:** Care should be taken to properly engineer the roof design so as to not overload the actual limits or manufacturer's recommended limits for each pipe support, the roof membrane, the roof top insulation, or the roof structure.

**Note:** Unipier has set the above load limits for each base to come within usual and customary roof structure, roof insulation, and roof membrane load limits. Unipier's manufacturing recommendations do not replace actual engineering required for each specific job.

## Technical Properties For Polycarbonate Resin\*

PROPERTY	ASTM TEST METHOD	VALUE
<b>PHYSICAL</b>		
Specific Gravity	D792	1.20
Specific Volume, in <sup>3</sup> /lb (cm <sup>3</sup> /g)	–	23.1 (0.83)
Weight/Volume, lbs/in <sup>3</sup> (g/cm <sup>3</sup> )	–	0.043 (1.20)
Water Absorption %	D570	–
24 hours @ 73°F (23°C)	–	0.15
Equilibrium, 73°F (23°C)	–	0.35
Equilibrium, 212°F (100°C)	–	0.58
Mold Shrinkage, in/in (mm/mm)	D955	0.005-0.007
Light Transmittance, % at 0.125"	D1003	89
Haze, % @ 0.125"	D1003	1
Refractive Index	–	1.586
<b>THERMAL</b>		
Deflection Temperature °F (°C)	D648	–
@ 66 psi (0.46 MPa)	–	–
@ 254 psi (1.82 MPa)	–	270 ( )
Specific Heat, Btu/lb/°F (kJ/kg/°K)	–	0.30 (1.25)
Thermal Conductivity	–	–
Btu-in/h-ft <sup>2</sup> -°F (W/Km)	–	1.35 (.19)
Coefficient of Thermal Expansion	–	–
in/in/°F (m.m/°C)	D696	3.75 x 10 <sup>-5</sup> (6.75 s 10 <sup>-5</sup> )
Vicat Softening Temperature, °F (°C)	D1525	305-315 (152-157)
Viscosity Midpoint	D1238	9.5
(Melt Flow Rate) g/10 min.	Condition 0	–
Brittleness Temperature, °F (°C)	D746	<-200 (-129)
Flammability Ratings	–	–
ASTM	D365°	AEB>1"
UL Standard 94° 1/16 (1.6 mm)	UL94	V-2
UL Standard 94° 1/8" (3.2 mm)	UL94	V-2
Oxygen Index	D2863	25.0
<b>PHYSICAL</b>		
Dielectric Strength, volts/mil (kV/mm)	D149	380 (15.0)
Short time, 125 mils (3.2mm)	–	–
Dielectric Constant	D150	–
60 Hz	–	3.17
106 Hz	–	2.96
Dielectric Factor	D150	–
60 Hz	–	0.0009
106 Hz	–	0.010
Volume Resistivity, ohm-cm	–	D257
@ 73°F, dry (23°C)	–	>10 <sup>16</sup>
Arc Resistance, sec	D495	–
Stainless Steel Electrodes	–	10-11
Tungsten Electrodes	–	120

PROPERTY	ASTM TEST METHOD	VALUE
<b>MECHANICAL</b>		
Tensile Strength, psi (MPa)	D638	–
Yield	–	9,000 (62)
Ultimate	–	10,000 (69)
Elongation, %	D638	–
Rupture	–	130
Flexural Strength, psi (MPa)	D790	14,000 (97)
Flexural Modules, 10 <sup>5</sup> psi (MPa)	D790	3.40 (2,300)
Compressive Strength, psi (MPa)	D695	12,500 (86)
Compressive Modules, psi (MPa)	D695	–
10 <sup>5</sup> osu (MPa)	–	3.45 (2,400)
Shear Strength, psi (MPa)	D732	–
Yield	–	6,000 (40)
Ultimate	–	10,000 (70)
Shear Modules, 10 <sup>5</sup> psi (MPa)	–	1.14 (790)
Izod Impact Strength, ft-lbs/in (J/m)	D1822	–
Notched, 1/8" thick (3.22mm)	–	15 (801)
Tensile Impact Strength, ft-lbs/in <sup>2</sup> (kJ/m <sup>2</sup> )	D1822	–
S-type	–	275 (579)
Dynatup Impact Strength, ft-lbs/in (J)	D3763	47 (64)
Fatigue Strength, psi @ 2.5mm	D671	–
cycles (MPa)	–	1,000 (7.0)
Rockwell Hardness	D785	–
M	–	70
R	–	118
Deformation Under Load %	D621	–
4000 psi @ 73°F (27 MPa @ 23°C)	–	0.2
4000 psi @ 158°F (27 MPa @ 70°C)	–	0.5
Taber Abrasion Resistance	–	–
Weight Loss, mg/1000 cycles	D1044	10

\*Polycarbonate Resin is used in all models indicated in catalog as Polycarbonate, and in all rollers.

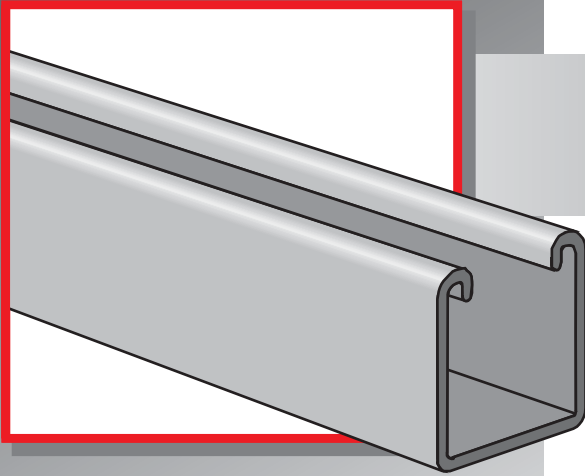

## JUNIOR CHANNEL

*Power-Strut junior channel sections are cold formed from prime quality cold rolled steel. Junior channel fittings are punched from hot rolled, pickled and oiled steel.*

### ■ STANDARD LENGTHS:

Standard length is 10 feet at a tolerance of  $\pm 1/8$  inches. Shorter lengths are available for a small cutting charge.

### ■ STANDARD DIMENSIONS FOR FITTINGS:

**Fitting Thickness:**  $1/8$ "  
**Fitting Width:**  $13/16$ "  
**Hole Diameter:**  $9/32$ "  
**Hole Spacing:**  $1 1/16$ " on centers and  $13/32$ " from end.

### ■ STANDARD FINISH:

PS 600J and PS 700J junior channels are available in a galvanized or painted green finish. All junior channel fittings are available in electro-galvanized finish.

### ■ ORDERING INFORMATION:

When ordering, add the length or size and finish to the part number. See pages 8-9 for finish abbreviations and an example.

# JUNIOR CHANNEL

Finish: Electro-galvanized Stock Width:  $1\frac{3}{16}$ " Stock Thickness:  $\frac{1}{8}$ " Stock Length: 10'  
 Order By: No., Size, and Finish Hole Spacing:  $1\frac{3}{32}$ " from end,  $1\frac{1}{16}$ " on center Hole Diameter:  $\frac{9}{32}$ "

**PS 600J – Channel ( $1\frac{3}{16}$ " x  $1\frac{3}{16}$ " x 19 ga.)**

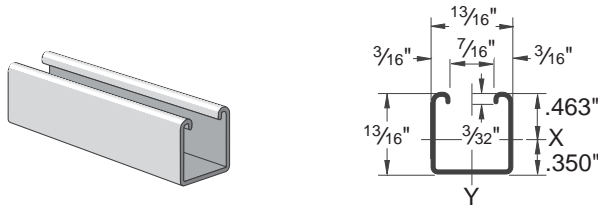

BEAM LOADING – PS 600J

Span (in)	Max Allowable Uniform Load (lbs)	Defl. at Uniform Load (in)	Uniform Loading at Deflection		
			Span/180 (lbs)	Span/240 (lbs)	Span/360 (lbs)
18	230	0.06	230	230	180
24	170	0.11	170	150	100
30	140	0.18	130	100	70
36	110	0.24	90	70	50
42	100	0.35	70	50	30
48	80	0.42	50	40	30
54	80	0.60	40	30	20
60	70	0.72	30	20	20

COLUMN LOADING – PS 600J

Unbraced Height (in)	Max. Allowable Load at Slot Face (lbs)	Maximum Column Load Applied at C.G.			
		K = 0.65 (lbs)	K = 0.80 (lbs)	K = 1.0 (lbs)	K = 1.2 (lbs)
18	600	1,660	1,400	1,100	860
24	490	1,300	1,010	740	590
30	420	990	740	560	450
36	340	770	590	450	370
42	300	630	490	380	310
48	260	540	420	330	270
54	240	470	370	290	**
60	210	410	330	**	**

\* Bearing load may govern capacity.

For concentrated load at center of span, divide uniform load by 2 and multiply corresponding deflection by 0.8. This load table is based on a solid channel section.

\*\*  $KL/r > 200$

Column loads are for allowable axial loads and must be reduced for eccentric loading.

## ELEMENTS OF SECTION

Weight (lbs./100 ft.)	Area of Section (Inch <sup>2</sup> )	X-X Axis			Y-Y Axis		
		Moment of Inertia (Inch <sup>4</sup> )	Section Modulus (Inch <sup>3</sup> )	Radius of Gyration (Inch)	Moment of Inertia (Inch <sup>4</sup> )	Section Modulus (Inch <sup>3</sup> )	Radius of Gyration (Inch)
36	0.107	0.009	0.020	0.295	0.012	0.029	0.333

**PS 3017 – Junior Channel Nuts**

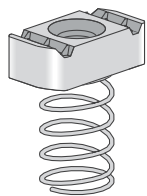

Size	Wt./100 pcs
8-32	1
10-32	1
10-24	1
1/4"	1

Use With: PS 600J channel

**PS 4017 – Junior Channel Nuts**

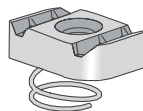

Size	Wt./100 pcs
8-32	1
10-32	1
10-24	1
1/4"	1

Use With: PS 700J channel

**PS 2029 – End Cap**



Use With: PS 600J

Weight/100 pcs: 2 lbs.

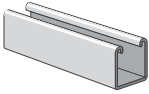

Finish: Electro-galvanized Stock Width:  $1\frac{3}{16}$ " Stock Thickness:  $\frac{1}{8}$ " Stock Length: 10'  
Order By: No., Size, and Finish Hole Spacing:  $1\frac{3}{32}$ " from end,  $1\frac{1}{16}$ " on center Hole Diameter:  $\frac{9}{32}$ "

**PS 700J – Channel ( $1\frac{3}{16}$ " x  $1\frac{3}{32}$ " x 19 ga.)**

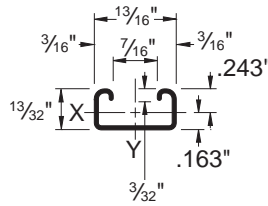
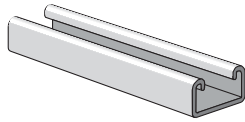

\* Bearing load may govern capacity.

\*\*  $KL_i > 200$

Column loads are for allowable axial loads and must be reduced for eccentric loading. For concentrated load at center of span, divide uniform load by 2 and multiply corresponding deflection by 0.8. This load table is based on a solid channel section.

**BEAM LOADING – PS 700J**

Span (in)	Max Allowable Uniform Load (lbs)	Defl. at Uniform Load (in)	Uniform Loading at Deflection		
			Span/180 (lbs)	Span/240 (lbs)	Span/360 (lbs)
18	80	0.12	60	50	30
24	60	0.22	40	30	20
30	50	0.36	20	20	10
36	40	0.50	20	10	10

**COLUMN LOADING – PS 700J**

Unbraced Height (in)	Max. Allowable Load at Slot Face (lbs)	Maximum Column Load Applied at C.G.			
		K = 0.65 (lbs)	K = 0.80 (lbs)	K = 1.0 (lbs)	K = 1.2 (lbs)
18	420	1,200	990	720	510
24	330	900	640	410	280
30	260	620	410	**	**
36	200	430	280	**	**

**ELEMENTS OF SECTION**

Weight (lbs./100 ft.)	Area of Section (Inch <sup>2</sup> )	X-X Axis			Y-Y Axis		
		Moment of Inertia (Inch <sup>4</sup> )	Section Modulus (Inch <sup>3</sup> )	Radius of Gyration (Inch)	Moment of Inertia (Inch <sup>4</sup> )	Section Modulus (Inch <sup>3</sup> )	Radius of Gyration (Inch)
25	0.074	0.002	0.007	0.150	0.007	0.017	0.307

**PS 2013 – Square Washer**

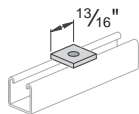

Weight/100 pcs: 2 lbs.

**PS 2014 – Two-Hole Splice Plate**

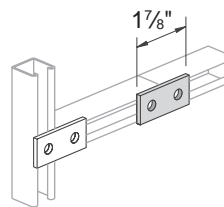

Weight/100 pcs: 5 lbs.

**PS 2015 – Three-Hole Splice Plate**

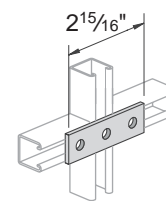

Weight/100 pcs: 8 lbs.

**PS 2016 – Four-Hole Splice Plate**

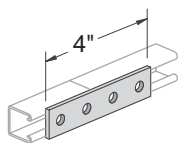

Weight/100 pcs: 11 lbs.

**PS 2033 – Flat Angle Plate**

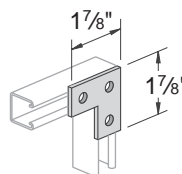

Weight/100 pcs: 8 lbs.

**PS 2034 – Tee Plate**

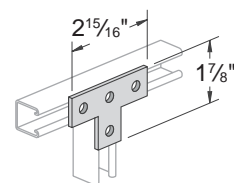

Weight/100 pcs: 11 lbs.

## PS 2008 – Two-Hole Corner Angle

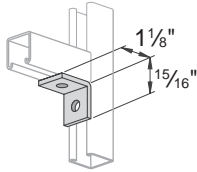

Weight/100 pcs: 5 lbs.

## PS 2025 – Three-Hole Corner Angle

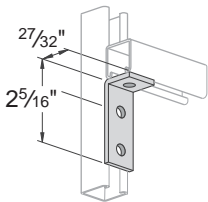

Weight/100 pcs: 8 lbs.

## PS 2024 – Four-Hole Corner Angle

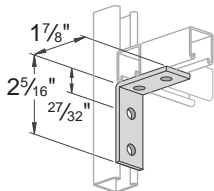

Weight/100 pcs: 11 lbs.

## PS 2026 – "Z" Support

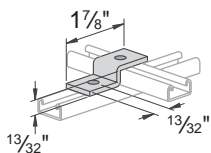

Use With: PS 700J

Weight/100 pcs: 6 lbs.

## PS 2017 – Two-Hole Corner Angle

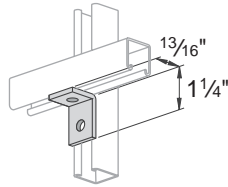

Weight/100 pcs: 5 lbs.

## PS 2037 – Three-Hole Corner Angle

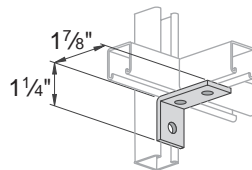

Weight/100 pcs: 8 lbs.

## PS 2023 R or L – Four-Hole Shelf Bracket

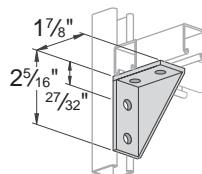

**Note:**  
Specify R (right) or L (left) when ordering  
Right Hand Illustrated

Weight/100 pcs: 19 lbs.

## PS 2011 – "U" Support

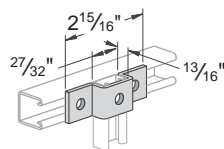

Use With: PS 600J

Weight/100 pcs: 12 lbs.

## PS 2018 – Three-Hole Corner Angle

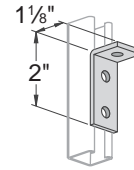

Weight/100 pcs: 8 lbs.

## PS 2019 – Four-Hole Corner Angle

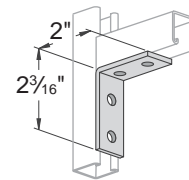

Weight/100 pcs: 11 lbs.

## PS 2010 – "Z" Support

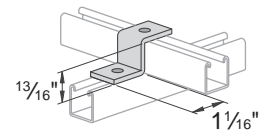

Use With: PS 600J

Weight/100 pcs: 7 lbs

## PS 2041 – Tubing Clamps

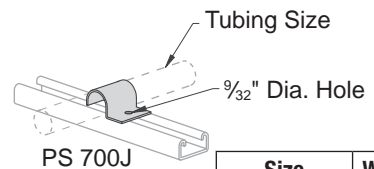

Size Tubing O.D.	Wt./100 pcs
1/4"	2
3/8"	
1/2"	
5/8"	
3/4"	3
7/8"	
1"	

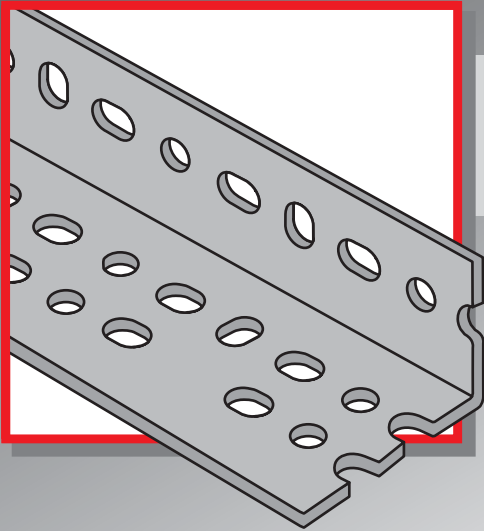

## POWER-ANGLE®

*A complete support system that's versatile, economical and easy to use.*

- *No drilling, welding or special tools necessary.*
- *Fast, efficient bolt-together construction*
- *Easy to change and adjust*

### **STANDARD LENGTHS:**

Standard lengths are 10' and 12'. Slotted angle is shipped in ten-piece bundles complete with 75 pieces of  $\frac{3}{8}$ " - 16 x  $\frac{3}{4}$ " hex head bolts and  $\frac{3}{8}$ " nuts.

### **STANDARD FINISH:**

Available in two durable, long-lasting finishes; pre-galvanized or Power-Green™.

### **ORDERING INFORMATION:**

When ordering, add the length or size and finish to the part number. See pages 8-9 for finish abbreviations and an example.



**Finish:** Pregalvanized or Acrylic Green **Stock Thickness:** .075(14 ga.) **Stock Length:** 10 & 12 Feet  
**Order By:** No., Length and Finish

**PA 158 – Light Duty**  
(1½" x 1½" x 14 ga.)

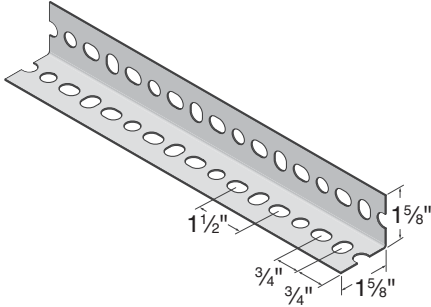

Weight/100 ft.: 66 lbs.

**PA 238 – Medium Duty**  
(1½" x 2¾" x 14 ga.)

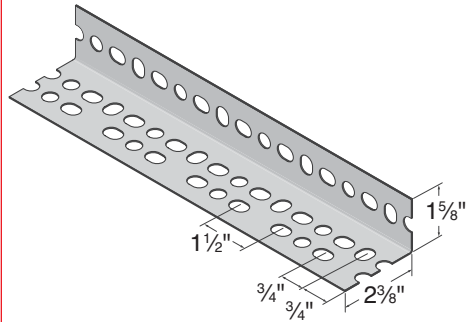

Weight/100 ft.: 80 lbs.

**PA 318 – Heavy Duty**  
(1½" x 3¼" x 12 ga.)

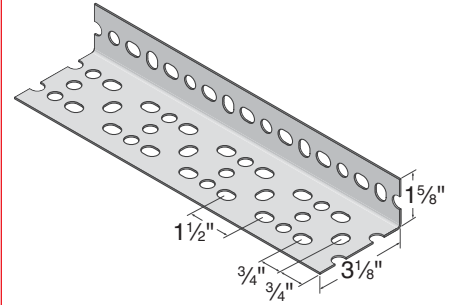

Weight/100 ft.: 130 lbs.

**Note:** Includes Serrated Nuts & Bolts

**PA 1SNB – Serrated Nuts & Bolts**

(Package of 75 nuts and 75 bolts)

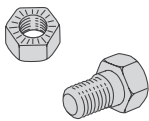

Weight/100 pcs: 7 lbs.

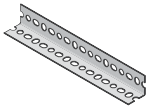

Metal Channel  
Fasteners  
Fittings  
Pipe & Conduit Clamps  
Electrical  
Concrete Inserts  
Solar Components  
Unipier®  
Jr. Channel  
Power-Angle  
Fiberglass  
Tech. Data

**Beam Load Calculations**

The beam loading depends on which slotted angle is used and the manner in which the beam is constructed. The diagrams on the next page show how individual slotted angle components can be combined to form a beam. The loading for each beam configuration is shown in the beam loading tables on the following pages.

**Example - Load "A"**

Load "A" is supported by two 48" sections of PA-238 (1<sup>5</sup>/<sub>8</sub>" x 2<sup>3</sup>/<sub>8</sub>"). The 48" row of Table 2 (page 131) indicates what each beam configuration will support. Since the columns are sorted from lowest to highest load, the first configuration that satisfies the requirement is "J" which will support 1,110 lbs.

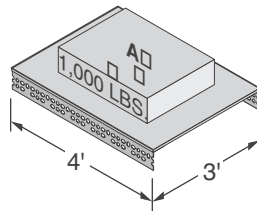

**Example - Load "B"**

Load "B" is supported by two 36" sections of PA-238 (1<sup>5</sup>/<sub>8</sub>" x 2<sup>3</sup>/<sub>8</sub>"). The 36" row of Table 2 (Page 131) indicates what each beam configuration will support. Since the columns are sorted from lowest to highest load, the first configuration that satisfies the requirement is "I" which will support 1,100 lbs.

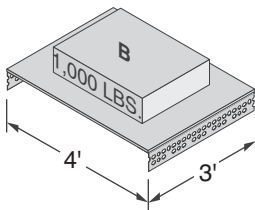

**Example - Load "C"**

Load "C" is supported by all four beam sections. The load is distributed uniformly on two 3' and two 4' beams which total 14' of supporting beam length. Dividing the 1,000 lb. load by 14-feet equals 72 lbs. per foot. Using the two longest (weakest) lengths, calculate the total weight as follows:

$$2 \text{ (beams)} \times 4' \text{ (length)} \times 72 \text{ lbs./ft.} = 576 \text{ lbs. total weight}$$

The 36" row of Table 2 (Page 131) indicates what each beam configuration will support. Since the columns are sorted from lowest to highest load, the first configuration that satisfies the requirement is "H" which will support 680 lbs. and is adequate for this requirement. The 3-foot beams configured in the same manner will support the load because they are shorter and stronger.

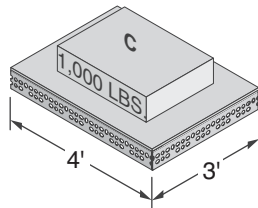

**Transverse Stiffeners**

When supporting concentrated loads, the capacity of a pair of slotted-angle beams can be increased by the addition of transverse stiffeners. These should be placed immediately under the load bearing point. The slotted-angle segment used as the stiffener is bolted into place using a metal connector at each junction.

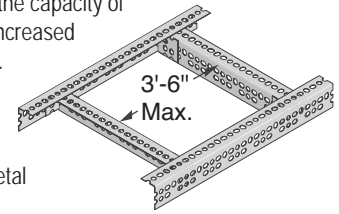

Beams that are 6' long or less require only one stiffener in the center of the span. Seven-foot beams need two stiffeners placed 2' from each end. Eight-foot beams require two stiffeners 2'6" from the ends. For beams with a nine-foot span, it is necessary to have three stiffeners at 2'3" intervals. Ten-foot beams need three stiffeners with 2'6" spacings.

For maximum effectiveness, transverse stiffeners should never be spaced more than 3'6" apart.

Note: All loads based on actual physical testing. Documentation available on request.

**Column Load Calculations**

Column sections are calculated as described in the following example: (Assumes use of PA-238 1<sup>5</sup>/<sub>8</sub>" x 2<sup>5</sup>/<sub>8</sub>", material.)

Since all load areas are supported equally by the 4-columns, the calculations are based on a single-column section.

Section MN is one-fourth of "X", or 250 pounds. Column section NP supports one-fourth of "Y" (250 pounds) plus the load supported by MN, or a total of 500 pounds. Section PQ supports one-fourth of "Z" (250 pounds) plus the 500 pound load on section NP, or a total of 750 pounds.

Column loads are based on free and unbraced column lengths. Since MN, NP and PQ are each 3' long, the load requirement is for a 36" section that will bear 750 pounds safely. A reference to Table 5 (Page 132) indicates that all sections designated "A" will support 2,280 lbs. and meet the necessary requirements.

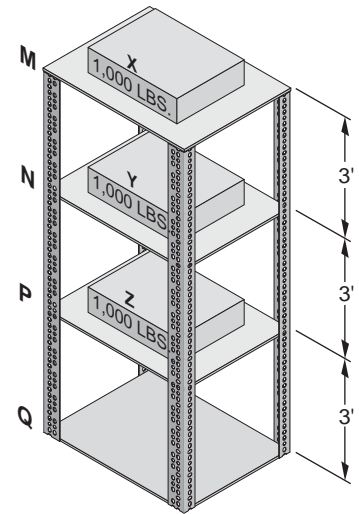

Note: To simplify assembly, we recommend using the same size material as for the horizontal members. This would be found in Table 2 (page 131) to match the 14 gauge 1<sup>5</sup>/<sub>8</sub>" x 2<sup>5</sup>/<sub>8</sub>" material selected for the beams of this structure.

Finish: Pregalvanized or Acrylic Green Stock Thickness: .075(14 ga.) Stock Length: 10 & 12 Feet  
Order By: No., Length and Finish

**Beam Configurations** (See corresponding letters in table on following page for load data)

**G – Two Single Pieces (Up)**

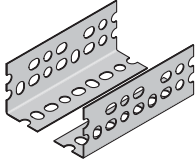

**H – Two Single Pieces (Level)**

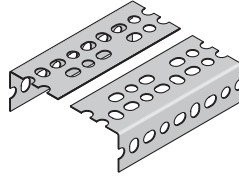

**I – Two Single Pieces (Down)**

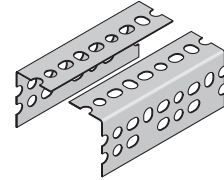

**J – Two Z-Sections**

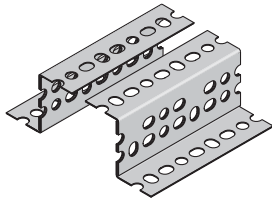

**K – Two Narrow Channels**

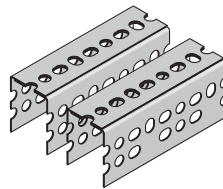

**L – Two Broad Channels**

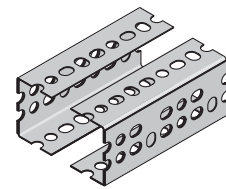

**M – Two T-Sections**

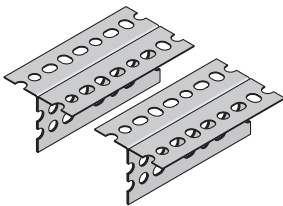

**N – Two I-Section**

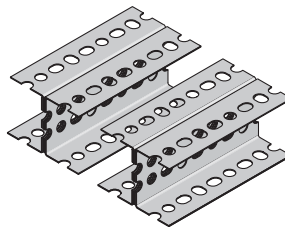

**O – Two J-Sections**

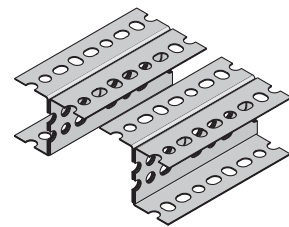

**Beam Configurations With Stiffeners**  
(See corresponding letters in table on following page for load data)

**P – Single Pieces w/Stiffener**

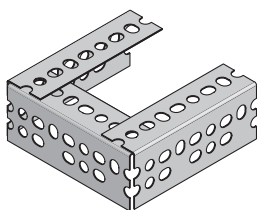

**Q – T-Sections w/Stiffener**

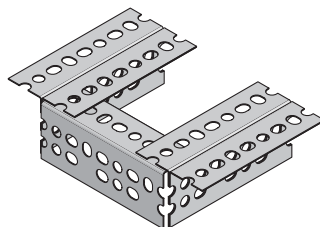

**R – Z-Sections w/Stiffener**

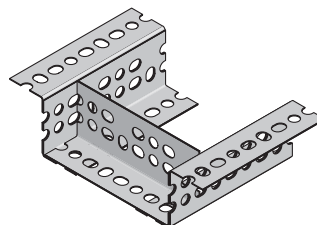

**R – I-Sections w/Stiffener**

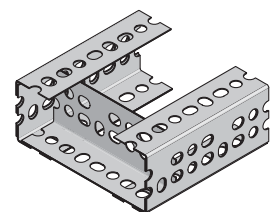

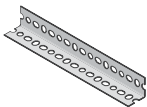

**Beam Loads PA 158 - Light Duty (1 5/8" x 1 5/8" x 14 ga.)**

Table 1

Beam Span (Inches)	Beam Configuration (See Previous Page) Beam Load in Pounds*						
	G	H	I	P	L	R	M
	24	550	830	830	920	1,600	1,700
36	370	560	560	610	1,070	1,130	1,230
48	280	420	420	460	800	850	920
60	220	330	330	370	640	680	740
72	180	280	280	310	530	570	610
84	•	240	240	260	460	490	530
96	•	210	210	230	400	430	460
108	•	•	•	•	360	380	410
120	•	•	•	•	320	340	370

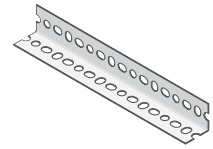

**Beam Loads PA 238 - Medium Duty (1 5/8" x 2 3/8" x 14 ga.)**

Table 2

Beam Span (Inches)	Beam Configuration (See Previous Page) - Beam Load in Pounds*											
	G	H	I	P	J	L	R	M	K	Q	O	N
24	700	1,020	1,660	1,740	2,220	3,170	3,230	3,490	3,590	3,630	6,060	7,560
36	460	680	1,100	1,160	1,480	2,110	2,150	2,320	2,390	2,420	4,040	5,040
48	350	510	830	870	1,110	1,580	1,620	1,740	1,800	1,810	3,030	3,780
60	280	410	660	700	890	1,270	1,290	1,390	1,440	1,450	2,420	3,020
72	230	340	550	580	740	1,060	1,080	1,160	1,200	1,210	2,020	2,520
84	•	290	470	500	630	910	920	1,000	1,030	1,040	1,730	2,160
96	•	260	410	440	550	790	810	870	900	910	1,520	1,890
108	•	•	•	•	490	700	720	770	800	810	1,350	1,680
120	•	•	•	•	440	630	650	700	720	730	1,210	1,510

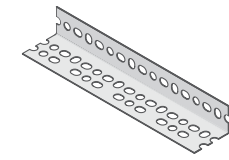

**Beam Loads PA 318 - Heavy Duty (1 5/8" x 3 1/8" x 12 ga.)**

Table 3

Beam Span (Inches)	Beam Configuration (See Previous Page) - Beam Load in Pounds*											
	G	H	I	P	J	L	R	M	K	Q	O	N
24	1,790	1,610	4,300	4,960	6,520	7,910	8,070	9,920	9,990	10,170	14,600	16,120
36	1,200	1,070	2,870	3,310	4,350	5,270	5,380	6,610	6,660	6,780	9,730	10,750
48	900	810	2,150	2,480	3,260	3,950	4,030	4,960	4,990	5,080	7,300	8,060
60	720	640	1,720	1,980	2,610	3,160	3,230	3,970	4,000	4,070	5,840	6,450
72	600	540	1,430	1,650	2,170	2,640	2,690	3,310	3,330	3,390	4,870	5,370
84	•	460	1,230	1,420	1,860	2,260	2,300	2,830	2,850	2,910	4,170	4,610
96	•	400	1,080	1,240	1,630	1,980	2,020	2,480	2,500	2,540	3,650	4,030
108	•	•	•	1,100	1,450	1,760	1,790	2,200	2,220	2,260	3,240	3,580
120	•	•	•	990	1,300	1,580	1,610	1,980	2,000	2,030	2,920	3,220

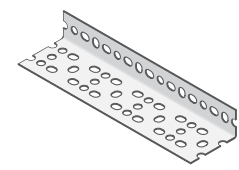

\* Based on simple beam condition with uniform loads on parallel beams.  
To determine concentrated load capacity at mid-span, multiply uniform load by 0.5.

Finish: Pregalvanized or Acrylic Green Stock Thickness: .075(14 ga.) Stock Length: 10 & 12 Feet

Order By: No., Length and Finish

## Column Sections

(See corresponding letters in table on right for load data)

**A – Single Piece**

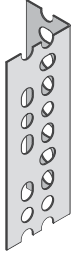

**B – T-Section**

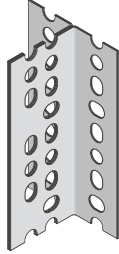

**B – Broad Channel Section**

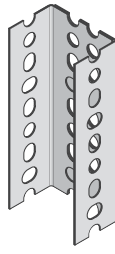

**B – Narrow Channel Section**

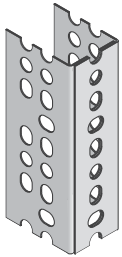

**C – Uneven T-Section**

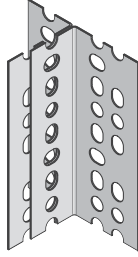

**C – Uneven Channel Section**

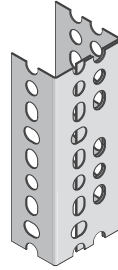

**D – Dual Channel Section**

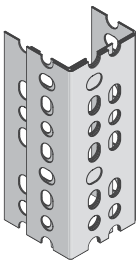

**D – T-Channel Section**

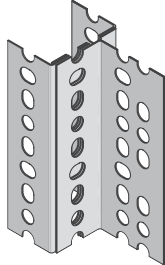

**D – T-Channel Section**

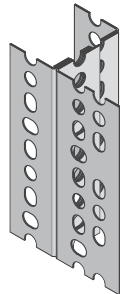

**E – I-Section**

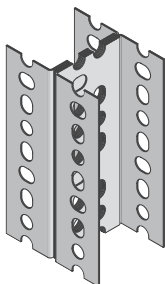

**F – Uneven I-Section**

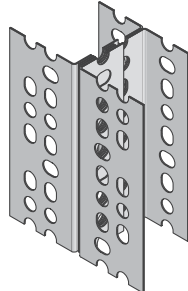

## Column Load

### PA 158 – Light Duty (1½" x 1½" x 14 ga.)

Table 4

Column Height (Inches)	Column Load in Pounds*	
	Column Sections (See Left Side of Page)	
	A	B
36"	1,450	3,850
48"	1,150	3,500
60"	950	3,000
72"	750	2,500

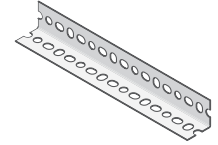

### PA 238 – Medium Duty (1½" x 2¾" x 14 ga.)

Table 5

Column Height (Inches)	Column Load in Pounds*					
	Column Sections (See Left Side of Page)					
	A	B	C	D	E	F
36"	2,280	4,760	4,940	7,270	9,520	9,865
48"	1,970	4,490	4,680	6,920	8,970	9,330
60"	1,520	3,995	4,310	6,370	7,990	8,620
72"	1,070	3,140	3,870	5,840	6,280	7,715
84"	660	2,340	3,665	4,930	4,660	6,740
96"	•	1,750	2,700	3,850	3,500	5,365
108"	•	•	2,060	2,870	•	4,115
120"	•	•	1,610	2,690	•	3,210

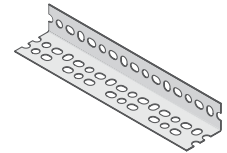

### PA 318 – Heavy Duty (1½" x 3½" x 12 ga.)

Table 6

Column Height (Inches)	Column Load in Pounds*					
	Column Sections (See Left Side of Page)					
	A	B	C	D	E	F
36"	3,470	7,970	8,770	12,560	15,940	17,550
48"	2,870	7,360	8,580	11,970	14,750	17,150
60"	1,970	6,570	8,180	11,360	13,160	16,360
72"	1,280	5,270	7,690	10,480	10,560	15,360
84"	•	3,670	6,970	9,470	7,370	13,970
96"	•	2,580	6,260	8,370	5,170	12,570
108"	•	•	5,460	6,880	•	10,970
120"	•	•	4,460	5,370	•	8,960

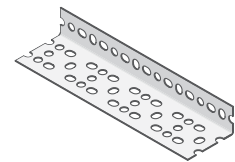

\* Column Loads are concentric without intermediate lateral support.

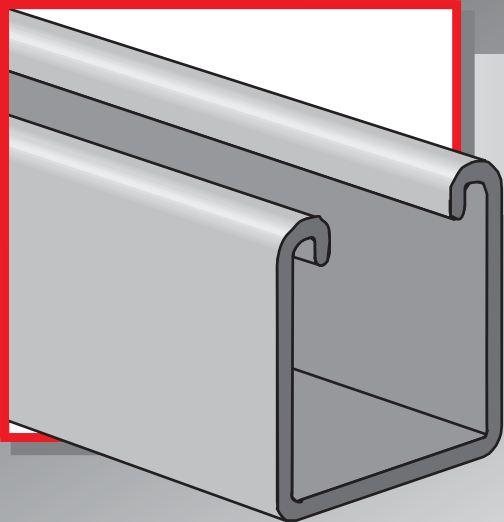
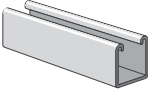

**FIBERGLASS**

*The installation of fiberglass channel and accessories is similar to the installation of metallic channel and accessories. All standard installation practices and procedures apply. In general, special handling is not required. Fabrication of Aickinstrut components requires just three simple operations; cutting, drilling and sealing.*

- Technical Data
- Fiberglass**
- Power-Angle
- Jr. Channel
- Unipier®
- Solar Components
- Concrete Inserts
- Electrical
- Pipe & Conduit/Clamps
- Fittings
- Fasteners
- Metal Channel

## Aickinstrut Specifications

### AICKINSTRUT FABRICATION

The installation of fiberglass channel and accessories is similar to the installation of metallic channel and accessories. All standard installation practices and procedures apply. In general, special handling is not required. Fabrication of Aickinstrut components requires just three simple operations; cutting, drilling and sealing as described below.

**Cutting** – Cutting can be accomplished with a wide variety of saws. Hand held saws, such as hack saws (24 to 32 teeth per inch) are suitable when a few number of cuts are required. For frequent cutting, a circular power saw with a carbide-tipped masonry blade yields the best results and the greatest number of cuts. When using a power saw, dust filter masks, gloves and long sleeve clothing should be worn.

**Drilling** – Any standard twist bit, even when used with battery-powered drills will work well. Carbide-tipped drill bits are recommended.

**Sealing** – To protect against future migration of corrosive elements into the cut sections, all cuts and holes should be properly sealed using Aickincoat or Aickinzip.

### LABOR SAVINGS

Aickinstrut fiberglass structural members can be cut and drilled at a much faster rate than steel. Typically, fiberglass can be fabricated in less than half the time. As a result, substantial labor savings will be realized. Also, Aickinstrut products average 1/3 the weight of their steel counterparts, making them much easier to handle on the job site.

### RELATIVE MATERIAL COSTS

Aickinstrut materials are advantageously priced relative to specialty metals traditionally used in corrosive environments. Aickinstrut, even though slightly more expensive than pre-galvanized channel, can be used with the knowledge that it will not have to be maintained regularly or replaced after a brief time. Should pre-galvanized channel have to be replaced once, its cost far outweighs the expense of doing the initial installation with Aickinstrut.

### MATERIAL

The finished Aickinstrut application will utilize a combination of materials from the following resin families:

Material Code	Material
E	PVC (extruded)
P	Polyester (pultruded)
V	Vinyl ester (pultruded)
PU	Polyurethane (injection molded)
PP	Polypropylene (injection molded)
N	Nylon (injection molded)

The ability of each material to handle high and low temperatures, chemical exposures and static loads is covered in each of the following sections. By using these criteria, you will be able to select the optimal Aickinstrut Channel, Fittings and Accessories for your particular applications.

### OPERATING ENVIRONMENT

In order to design an Aickinstrut system for your application, consideration should be given to the maximum operating conditions. These “worst case” conditions will determine which type of Aickinstrut materials are best suited for your application. The three “worst case” operating conditions to consider are:

- Temperature
- Chemical Environment
- Loading

**Temperature Ranges** – Aickinstrut is supplied in six different materials covering distinct temperature ranges. Materials should be chosen which meet or exceed the minimum and maximum temperatures for your applications.

Material Code	Low Temperature	High Temperature
E	-25°F	130°F
P	-35°F	200°F
V	-35°F	200°F
PU	-40°F	140°F
PP	-30°F	150°F
N	-20°F	150°F

The temperature ranges indicated are meant to be used only as a general guideline. Continual exposure to elevated temperatures reduces the strength properties of plastics and glass reinforced fiberglass. Actual resin test data confirms that a 50% reduction in strength occurs at the extreme high temperature levels.

**Chemical Resistance** – Each resin family has its own specifications regarding its performance against corrosion resistance. Use the following chart to determine which Aickinstrut material system will provide the best performance for your particular application. The results in the chart are based upon immersion for a 24 hour period. This is typically the “worst case” exposure to corrosion. Less severe contact such as spills, splashes and vapor condensate will exceed the performance results listed in the table.

**Loading** – Channel loading is defined on pages 140-141. Additional loading and design limitations for fittings and accessories are described in the appropriate section for that part.

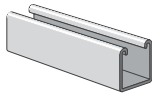

**Aickinstrut Specifications**

**1.0 SCOPE**

- 1.1 This specification covers the requirements for the Aickinstrut Nonmetallic Channel Framing System.

**2.0 MATERIAL**

- 2.1 FRP channel shall be of pultruded glass reinforced polyester or vinyl ester resin having the physical property values listed in this catalog.
- 2.2 PVC channel shall be of extruded polyvinyl chloride having the physical property values listed in this catalog.
- 2.3 Some accessories shall be of injection molded, 40% long glass fiber reinforced polyurethane, polypropylene or nylon.

**3.0 COMPOSITION**

- 3.1 Glass reinforced channel shall have a synthetic surfacing veil applied on exterior surfaces to improve weatherability and inhibit ultraviolet degradation. An ultraviolet stabilizer shall be incorporated in the resin formulation to further inhibit ultraviolet degradation.
- 3.2 PVC channel shall be manufactured from a U.V. stabilized resin and incorporate dark gray pigment to improve weatherability and inhibit ultraviolet degradation.

**4.0 STRUCTURAL DESIGN**

- 4.1 Channel shall incorporate Aickinstrut's patented flange profile design which allows full and positive interlocking contact of channel accessories and prohibits premature flange failure from torqued accessories.
- 4.2 Channel profile dimensions shall be:
  - 1<sup>5</sup>/<sub>8</sub>" x 1<sup>5</sup>/<sub>8</sub>" x 1/8",
  - 1<sup>1</sup>/<sub>2</sub>" x 1<sup>1</sup>/<sub>2</sub>" x 1/8", or
  - 1<sup>1</sup>/<sub>2</sub>" x 1<sup>1</sup>/<sub>8</sub>" x 1/8".
- 4.3 All 1<sup>5</sup>/<sub>8</sub>" x 1<sup>5</sup>/<sub>8</sub>" channel profiles shall have a minimum pull out resistance of 1,000 pounds when load is applied over a 3/8" long section of the inside flanges.

- 4.4 Channel section lengths shall be supplied in 10' or 20' lengths ( $\pm 1/8"$ ).
- 4.5 Universal Pipe Clamps shall have full interlocking contact with interior channel flanges to maximize pull-out resistance and be adjustable to accommodate a minimum 3/4" variance in piping or conduit O.D. sizes.

**5.0 STANDARDS**

- 5.1 Glass reinforced and PVC channels covered in this specification shall have a flame spread rating of 25 or less when tested per ASTM E84 and meet the requirements of UL 94V0 thereby qualifying them as Class 1 material in the Uniform Building Code.
- 5.2 Glass reinforced channels covered in this specification shall comply with the requirements of ASTM D 3917 and ASTM D 4385 which govern the dimensional tolerance and visual defects of pultruded shapes.

**6.0 GENERAL**

- 6.1 Aickinstrut Nonmetallic Channel Framing shall be furnished as a system which includes all the necessary fasteners, channel splice plates, brackets, sealants, hangers, pipe clamps, etc.
- 6.2 Nonmetallic fasteners shall be manufactured from long glass fiber reinforced polyurethane to ensure maximum strength and corrosion resistance.
- 6.3 All components of the Aickinstrut Channel Framing System shall be nonmetallic except where type 316 stainless steel hardware is used as part of the assembly.
- 6.4 Aickinstrut is manufactured by Aickinstrut, a subsidiary of T. J. Cope, Philadelphia, Pennsylvania, 1-800-426-4293.
- 6.5 The manufacturer shall not have had less than 10 years experience in manufacturing strut systems.
- 6.6 All products are manufactured in the United States of America.



## Chemical Compatibility Table

Chemical	Series E (Rigid PVC) 70°-160°F		Series P (Poly/Glass) 70°-160°F		Series V (Vinyl/Glass) 70°-160°F		Series K (PVDF) 70°-160°F		Series PU (Polyurethane) 70°-160°F		Series N (Nylon) 70°-160°F	
Acetic Acid, Up to 10%	R	R	R	R	R	R	R	R	R	-	NR	NR
Acetic Acid, Up to 50%	R	R	R	R	R	R	R	R	R	-	NR	NR
Acetone, Up to 10%	NR	NR	NR	NR	NR	NR	NR	NR	R	-	R	R
Aluminum Hydroxide	R	R	R	R	R	R	R	R	R	-	NR	NR
Ammonium Hydroxide (Aqueous Ammonia), Up to 5%	R	R	NR	NR	R	R	R	R	R	-	-	-
Ammonium Hydroxide, Up to 10%	R	R	NR	NR	R	150°	R	R	R	-	-	-
Ammonium Hydroxide, Up to 20%	R	R	NR	NR	R	150°	R	R	R	-	-	-
Ammonium Nitrate	R	NR	R	R	R	R	R	R	R	-	-	-
Ammonium Phosphate	R	R	R	NR	R	R	R	R	R	-	-	-
Ammonium Sulfide, saturated	R	R	NR	NR	R	120°	R	R	R	-	-	-
Aqua Regia, fumes	NR	NR	NR	NR	R	150°	R	R	NR	-	-	-
Benzene	NR	NR	NR	NR	NR	NR	NR	R	R	R	R	R
Benzoic Acid	R	R	R	R	R	R	R	R	R	-	-	-
Bromine, wet gas	R	NR	NR	NR	R	100°	R	R	-	-	-	-
Butylene Glycol, Up to 100%	R	R	R	R	R	R	R	R	R	-	R	R
Butyric Acid, Up to 50%	NR	NR	R	R	R	R	R	R	R	-	-	-
Calcium Hydroxide	R	R	R	NR	R	R	R	R	R	-	-	-
Calcium Hypochlorite	R	R	R	NR	R	R	R	R	R	-	NR	NR
Chlorine, Dry Gas	NR	NR	NR	NR	R	R	R	R	-	-	-	-
Chlorine, Wet Gas	NR	NR	NR	NR	R	R	R	R	-	-	-	-
Chlorine, Liquid	NR	NR	NR	NR	NR	NR	R	R	-	-	-	-
Chlorine, Water	NR	NR	R	R	R	R	R	R	R	-	NR	NR
Chromic Acid, Up to 5%	R	R	NR	NR	R	R	R	R	-	-	R	R
Copper Chloride	R	R	R	R	R	R	R	R	R	-	-	-
Copper Cyanide	R	R	R	NR	R	R	R	R	R	-	-	-
Copper Fluoride	R	R	R	NR	R	R	R	R	R	-	-	-
Copper Nitrate	R	R	R	R	R	R	R	R	R	-	-	-
Copper Sulfate	R	R	R	R	R	R	R	R	R	-	-	-
Dechlorinated Brine Storage	R	R	-	-	R	R	R	R	R	-	-	-
Esters, Fatty Acid	NR	NR	R	R	R	R	R	R	R	-	-	-
Ferric Chloride	R	R	R	R	R	R	R	R	R	-	-	-
Ferrous Chloride	R	R	R	R	R	R	R	R	R	-	-	-
Fluoboric Acid	R	R	R	120°	R	R	R	R	-	-	-	-
Fluosilicic Acid, Up to 10%	NR	NR	NR	NR	R	R	R	R	-	-	NR	NR
Fluosilicic Acid, Up to 32%	NR	NR	NR	NR	R	100°	R	R	-	-	-	-
Formic Acid, Up to 10%	R	R	NR	NR	R	R	R	R	R	-	NR	NR
Formic Acid, Up to 50%	R	R	NR	NR	R	100°	R	R	R	-	-	-
Gasoline, Aviation	R	NR	R	NR	R	R	R	R	R	-	-	-
Green Liquor, Pulp Mill	R	R	-	-	R	R	R	R	-	-	-	-
Hydrochloric Acid Up to 15%	R	R	R	NR	R	R	R	R	R	-	-	-
Hydrochloric Acid Up to 37%	R	R	R	NR	R	R	R	R	R	-	-	-
Hydrofluoric Acid, Up to 10%	R	R	NR	NR	R	150°	R	R	-	-	-	-
Hydrofluoric Acid, Up to 20%	R	NR	NR	NR	R	100°	R	R	-	-	-	-
Hydrogen Chloride, Wet Gas	NR	NR	R	NR	R	R	R	R	NR	-	-	-
Hydrogen Sulfide, Wet Gas	R	R	R	NR	R	R	R	R	R	-	-	-

Legend: "NR" indicates "Not Recommended" for use;  
 "R" indicates "Recommended";  
 "-" indicates no information available

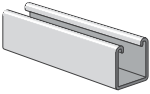

**Chemical Compatibility Table**

Chemical	Series E (Rigid PVC) 70°-160°F		Series P (Poly/Glass) 70°-160°F		Series V (Vinyl/Glass) 70°-160°F		Series K (PVDF) 70°-160°F		Series PU (Polyurethane) 70°-160°F		Series N (Nylon) 70°-160°F	
	R	R	R	NR	R	R	R	R	R	-	-	-
Lactic Acid	R	R	R	NR	R	R	R	R	R	-	-	-
Lead Nitrate	R	R	-	-	R	R	R	R	R	-	-	-
Magnesium Hydroxide	R	R	NR	NR	R	R	R	R	R	-	R	R
Nickel Sulfate, Low pH	R	R	NR	NR	R	R	R	R	R	-	-	-
Nickel Sulfate, High pH	R	R	NR	NR	R	R	R	R	R	-	-	-
Nitric Acid, Up to 5%	R	R	NR	NR	R	150°	R	R	R	-	-	-
Nitric Acid, Up to 35%	R	R	NR	NR	R	150°	R	R	R	-	-	-
Nitric Acid, Vapor	R	R	NR	NR	R	R	R	R	-	-	-	-
Perchloric Acid, Up to 10%	NR	NR	NR	NR	R	150°	R	R	-	-	NR	NR
Pickling Liquids, 3-5% H2SO4	R	R	R	R	R	R	R	R	R	-	-	-
Phosphoric Acid	R	R	NR	NR	R	R	R	R	R	-	NR	NR
Phosphoric Acid, Super or Poly (115%, P20%)	R	R	NR	NR	R	R	R	R	-	-	-	-
Phosphoric Acid Vapor or Condensate	R	R	NR	NR	R	R	R	R	-	-	-	-
Potassium Chloride	R	R	R	R	R	R	R	R	R	-	-	-
Potassium Nitrate	R	R	R	R	R	R	R	R	R	-	-	-
Potassium Persulfate	R	R	NR	NR	R	R	R	R	R	-	-	-
Silver Cyanide, Up to 5%	R	R	NR	NR	R	R	R	R	R	-	-	-
Sodium Hydroxide, Up to 25%	R	R	NR	NR	R	150°	R	R	R	-	-	-
Sodium Hydroxide, up to 50%	R	R	NR	NR	R	180°	R	R	-	-	R	R
Sodium Hypochlorite, Up to 15%	R	R	NR	NR	R	150°	R	R	R	-	NR	NR
Sodium Nitrate	R	R	R	R	R	R	R	R	R	-	-	-
Sodium Sulfate	R	R	R	NR	R	R	R	R	R	-	-	-
Sodium Sulfide	R	R	NR	NR	R	R	R	R	R	-	-	-
Sulfuric Acid, Up to 25%	R	R	R	R	R	R	R	R	R	-	NR	NR
Sulfuric Acid, Up to 50%	R	R	NR	NR	R	R	R	R	R	-	-	-
Sulfuric Acid, Up to 70%	R	R	NR	NR	R	R	R	R	R	-	NR	NR
Sulfuric Acid, Up to 75%	NR	NR	NR	NR	R	120°	R	R	-	-	NR	NR
Sulfuric Acid, Up to 80%	NR	NR	NR	NR	NR	NR	NR	NR	-	-	NR	NR
Sulfuric Acid, Vapor	R	R	R	NR	R	R	R	R	-	-	-	-
Trichlorethylene, Fumes	NR	NR	NR	NR	R	120°	R	R	NR	-	-	-
Trisodium Phosphate	R	R	R	NR	R	R	R	R	R	-	-	-
Urea	R	R	R	NR	R	150°	R	R	R	-	R	R
Vegetable Oils	R	R	R	R	R	R	R	R	R	-	R	R
Vinegar	R	R	R	R	R	R	R	R	R	R	R	R
White Liquor, Pulp Mill	R	R	-	-	R	R	R	R	-	-	-	-

**Note:** The recommendations contained in this table are made without guarantee of representation as to results. Since the actual use by others is beyond our control, no guarantee, expressed or implied, is made by T.J. Cope, Inc. as to effects of such use or results to be obtained nor does T.J. Cope, Inc. assume any liability arising out of the use by others of the products referenced in this table. Nor is the information herein to be construed as absolutely complete since additional information may be needed or desirable when particular or exceptional conditions or circumstances exist or because of applicable laws or government regulations. We suggest that you evaluate these recommendations and suggestions in your own laboratory prior to use. Our responsibility for claims arising from breach of warranty, negligence, or otherwise is limited to the purchase price of the material.

**Legend:** "NR" indicates "Not Recommended" for use; "R" indicates "Recommended"; "-" indicates no information available

Metal Channel  
Fasteners  
Fittings  
Clamps  
Pipe & Conduit  
Electrical  
Concrete Inserts  
Solar Components  
Unipier®  
Jr. Channel  
Power-Angle  
Fiberglass  
Tech. Data

## Channel

### CHANNEL FRAMING

All Aickinstruct channels, except the SST series, incorporate a patented flange design which provides reliable fastening and interlocking of Aickinstruct components and accessories.

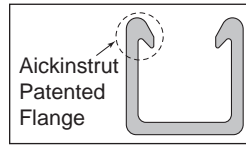

Channels are provided in standard lengths of 10' with longer lengths available upon request. Aickinstruct single channels come packaged in boxes of 100' (10 pieces) while the double channels are packaged in boxes containing 40' (4 pieces).

Aickinstruct channel is available in three materials:

- Polyester (P material),
- Vinyl Ester (V material) and
- PVC (E material)

### POLYESTER AND VINYL ESTER MATERIALS

The polyester and vinyl ester channels are manufactured from the pultrusion process. In this process, the component is made by reinforcing a polymer resin (polyester or vinyl ester) with multiple strands of glass filament, alternating layers of glass mat and U.V. resistant surfacing veils. The glass is drawn through the liquid resin, which coats and saturates the fibers. The combination of resin, glass and veil is then continuously guided and pulled (pultruded) through a heated die that determines the shape of the component.

In the die, the resin is cured to form a permanent, reinforced part which can be cut to a specific length. Since the hardened fiberglass pultrusion is reinforced with an internal arrangement of permanently bonded continuous glass fibers, it possesses great strength.

In addition, pultruded fiberglass components exhibit exceptional corrosion and fire resistance. These attributes make fiberglass the material of choice for many harsh industrial applications.

The polyester and vinyl ester channels are color coded. Polyester channels are colored gray and the vinyl ester channels are colored beige.

### PVC MATERIALS

The PVC channels are manufactured from the extrusion process. In this process, the component is made by a PVC resin mixture being continuously fed through a heated die that determines the shape of the component.

In the die, the resin is cured to form a permanent, extruded part that can be cut to a specific length. Unlike pultruded components, extruded components do not incorporate glass-reinforcement; consequently, they do not exhibit the same beam strength as their pultruded counterparts. PVC components, however, exhibit exceptional corrosion and fire resistance. These features make PVC channels an excellent alternative when excessive beam strength is not required. PVC channels are color coded dark gray.

### CHANNEL AVAILABILITY CHART

The following chart illustrates the availability of materials in the different channel profiles.

Channel Profile	Polyester (P)	Vinyl Ester (V)	PVC (E)
Series 2000, 2200, 2300	X	X	X
Series 1500, 1700, 1800	X	X	N/A
Series 1000, 1200, 1300	X	X	X
Series 2100	X	X	N/A
Series 1600	X	X	N/A
Series 1100	X	X	N/A

### CONCRETE EMBEDMENT CHANNEL

#### PART NO. – 20E-2300

In certain applications, it is necessary to embed a corrosion resistant channel into a new pouring of concrete. For these applications, Aickinstruct concrete embedment channel is recommended. Aickinstruct embedment channel

is available in three material types; PVC, polyester and vinyl ester. The PVC embedment channel is extruded as one piece while the polyester and vinyl ester embedment channel is a two piece bonded type design. The PVC embedment channel is available in the 1<sup>5</sup>/<sub>8</sub>" and 1<sup>1</sup>/<sub>8</sub>" profiles while polyester and vinyl ester embedment channels are available in all three profiles (1<sup>5</sup>/<sub>8</sub>", 1<sup>1</sup>/<sub>2</sub>" & 1<sup>1</sup>/<sub>8</sub>").

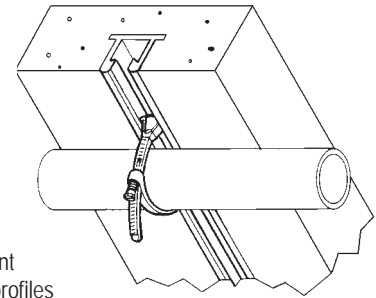

The embedment channel utilizes two continuous protruding flanges in the profile base to retain the channel in the concrete. Mounting the embedment channel flush with the concrete surface is a convenient way to secure piping, conduits or electrical enclosures to a wall or ceiling. The PVC embedment channel is extremely high in strength. When embedded in 3,000 PSI concrete, the concrete will fail before the channel is pulled out.

### AICKINSTRUT SST CHANNEL

Aickinstruct SST Fiberglass Channel incorporates a standard channel profile that will accommodate metallic pipe straps and clamps. SST channel is available in polyester or vinyl ester resin. All standard styles (solid, slotted, concrete insert and back-to-back) are also available. Please contact the factory for loading information for the SST Channel.

**Note:** Aickinstruct SST Channel is not compatible with the Aickinstruct pipe clamps, channel nuts, and grooved fittings shown in this catalog. Please contact Aickinstruct for information on a complete line of compatible clamps and channel nuts.

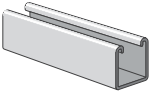

**HEAVY DUTY CHANNEL – AICKINSTRUT PROFILE**

<b>Standard</b> 20P-2000, 20V-2000, 20E-2000	<b>Slotted (1" x 3/8" Holes)</b> 20P-2200, 20V-2200, 20E-2200	<b>With Concrete Inserts</b> 20P-2300, 20V-2300, 20E-2300	<b>Back-to-Back</b> 20P-2100, 20V-2100

**MEDIUM DUTY CHANNEL – AICKINSTRUT PROFILE**

<b>Standard</b> 20P-1500, 20V-1500	<b>Slotted (1" x 3/8" Holes)</b> 20P-1700, 20V-1700	<b>With Concrete Inserts</b> 20P-1800, 20V-1800	<b>Back-to-Back</b> 20P-1600, 20V-1600

**LIGHT DUTY CHANNEL – AICKINSTRUT PROFILE**

<b>Standard</b> 20P-1000, 20V-1000, 20E-1000	<b>Slotted (1" x 3/8" Holes)</b> 20P-1200, 20V-1200, 20E-1200	<b>With Concrete Inserts</b> 20P-1300, 20V-1300, 20E-1300	<b>Back-to-Back</b> 20P-1100, 20V-1100

**HEAVY DUTY CHANNEL – STANDARD PROFILE**

<b>Standard</b> 20P-2000-SST, 20V-2000-SST	<b>Slotted (1" x 3/8" Holes)</b> 20P-2200-SST, 20V-2200-SST	<b>With Concrete Inserts</b> 20P-2300-SST, 20V-2300-SST	<b>Back-to-Back</b> 20P-2100-SST, 20V-2100-SST

## Channel Loading

### Flange Loading

Pull-out strength is the channel's resistance to a clamp or fastener inserted under the flange and put under tension. For additional information concerning specific channels, materials and their pull-out strengths, refer to the channel flange pull-out chart on the right.

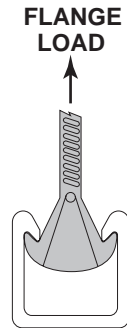

Heavy Duty Channel	Pull-Out Strength*
20V-2000	449
20P-2000	360
20E-2000	260
Medium Duty Channel	Pull-Out Strength*
20V-1500	229
20P-1500	219
Light Duty Channel	Pull-Out Strength*
20E-1000	239
20P-1000	213
20V-1000	213

\*Values shown represent a 3:1 safety factor

### Section Properties

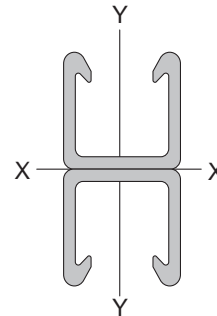
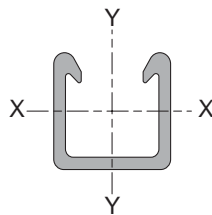

Section Number	Height (in.)	Width (in.)	Weight (lbs./ft.)	Area (in. <sup>2</sup> )	X - X Axis				Y - Y Axis		
					I (in. <sup>4</sup> )	R (in.)	C <sup>1</sup> (in.)	C <sup>2</sup> (in.)	I (in. <sup>4</sup> )	R (in.)	C (in.)
2000	1½	1½	0.82	1.06	0.31	0.54	0.70	0.93	0.42	0.63	0.82
2100	3½	1½	1.64	2.12	1.77	0.91	1.63	1.63	0.85	0.63	0.82
1500	1½	1½	0.55	0.71	0.19	0.52	0.62	0.88	0.25	0.59	0.75
1600	3	1½	1.10	1.42	1.02	0.85	1.50	1.50	0.49	0.59	0.75
1000	1½	1½	0.47	0.61	0.10	0.40	0.51	0.62	0.22	0.60	0.75
1100	2½	1½	0.94	1.22	0.42	0.59	1.13	1.13	0.44	0.60	0.75

### Beam Loading - PVC

The data listed in the Beam Loading Chart reflects testing conducted on Polyester (Type P) and vinyl ester (Type V) channels. PVC (Type E) material will differ from the Polyester/Vinyl ester Beam Loading Chart. To obtain the beam loading for PVC channel, reduce the load as follows:

$$\text{PVC Beam Load} = \frac{(\text{Polyester/Vinyl Ester Beam Load})}{4}$$

**Note:** PVC is not recommended for lengths over 24"

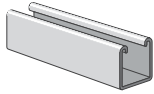

**Polyester/Vinyl Ester Beam Loading Chart**

Span	Part No.	Max. Uniform Beam Load (Safety Factor - 3:1) Load (lbs.)	Uniform Load at Defl. of 1/360 Span Deflection (in.)	Maximum Column Load (lbs.)	Deflection (in.)	Load (lbs.)
12" Span	20PV-2100	5,559	0.028	5,559	0.033	9,454
	20PV-1600	4,836	0.043	3,778		7,007
	20PV-1100	3,804	0.082	1,556		5,961
	20PV-2000	3,561	0.102	1,159		5,160
	20PV-1500	1,950	0.093	700		3,439
	20PV-1000	1,629	0.151	359		2,759
18" Span	20PV-2100	3,706	0.064	2,914	0.050	8,866
	20PV-1600	3,224	0.096	1,697		6,501
	20PV-1100	2,536	0.183	691		5,509
	20PV-2000	2,374	0.230	515		4,704
	20PV-1500	1,300	0.209	311		3,136
	20PV-1000	1,086	0.340	160		2,351
24" Span	20PV-2100	2,780	0.113	1,639	0.067	8,181
	20PV-1600	2,418	0.171	944		5,909
	20PV-1100	1,902	0.326	389		4,979
	20PV-2000	1,781	0.410	290		4,168
	20PV-1500	975	0.371	175		2,778
	20PV-1000	815	0.605	90		1,862
30" Span	20PV-2100	2,224	0.177	1,049	0.083	7,405
	20PV-1600	1,934	0.267	604		5,236
	20PV-1100	1,522	0.509	249		4,375
	20PV-2000	1,424	0.640	185		3,553
	20PV-1500	780	0.580	112		2,369
	20PV-1000	652	0.945	57		1,298
36" Span	20PV-2100	1,853	0.254	730	0.100	6,451
	20PV-1600	1,612	0.384	420		4,482
	20PV-1100	1,268	0.734	173		3,698
	20PV-2000	1,187	0.922	129		2,859
	20PV-1500	650	0.836	78		1,906
	20PV-1000	543	1.360	40		901
48" Span	20PV-2100	1,390	0.452	410	0.133	4,534
	20PV-1600	1,209	0.683	236		2,809
	20PV-1100	951	1.304	97		2,254
	20PV-2000	890	1.638	72		1,636
	20PV-1500	488	1.486	44		1,091
	20PV-1000	407	2.418	22		507
60" Span	20PV-2100	1,112	0.707	262	0.167	2,902
	20PV-1600	967	1.067	151		1,798
	20PV-1100	761	2.038	62		1,442
	20PV-2000	712	2.560	46		1,047
	20PV-1500	390	2.321	28		698
	20PV-1000	326	3.779	14		324
72" Span	20PV-2100	927	1.018	182	0.200	2,015
	20PV-1600	806	1.536	105		1,248
	20PV-1100	634	2.935	43		1,001
	20PV-2000	594	3.686	32		727
	20PV-1500	325	3.343	19		485
	20PV-1000	272	5.441	10		225

Metal Channel  
Fasteners  
Fittings  
Pipe & Conduit Clamps  
Electrical  
Concrete Inserts  
Solar Components  
Unipier®  
Jr. Channel  
Power-Angle  
Fiberglass  
Tech. Data

# FIBERGLASS

## Channel Fittings

Aickinstruct Channel Fittings are required to fabricate an Aickinstruct structure and are easily attached to Aickinstruct Channels with channel nuts and polyurethane fasteners. The fittings are offered in two types; fabricated (cut from flat stock) or molded. Fabricated fittings are made from either polyester or vinyl ester material. All molded fittings with the exception of the post bases are molded in polyurethane. Post bases are also offered in polypropylene.

The 2500 Series Fittings are manufactured from 1/2" flat material. The 2800 Series Fittings are manufactured from 3/8" flat material and feature grooves which stabilize the fittings when mounted to the open side of the channel. All channel fittings are provided with 13/32" holes which accommodate 3/8" hardware, however several of the new molded fittings are 1/4" thick and come with 9/16" holes 50PU-2616, 50PU-2611, and 50PU-2613. Larger diameter holes can be provided upon special request.

Legend
R = Right Hand
L = Left Hand
P Series Fittings are Grey
V Series Fittings are Beige
2500 Series - Flat
2800 Series - Grooved

**Note:** Illustrations depict grooved channel fittings.

**20P-2500, 20V-2500 (Flat)**  
**20P-2800, 20V-2800 (Grooved)**

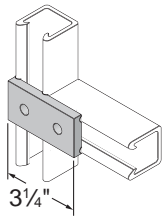

**20P-2502, 20V-2502 (Flat)**  
**20P-2802, 20V-2802 (Grooved)**

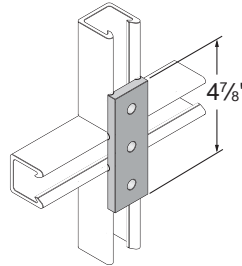

**20P-2504, 20V-2504 (Flat)**  
**20P-2804, 20V-2804 (Grooved)**

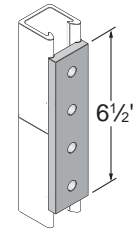

**20P-2506, 20V-2506 (Flat)**  
**20P-2806, 20V-2806 (Grooved)**

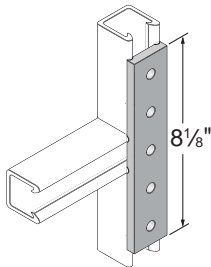

**50PU-2616**

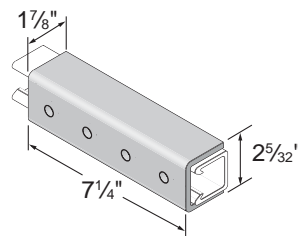

**Note:** 9/16" diameter holes

**20P-2508, 20V-2508 (Flat)**  
**20P-2808, 20V-2808 (Grooved)**

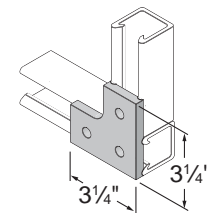

**20P-2510, 20V-2510 (Flat)**  
**20P-2810R, 20V-2810R (Grvd)**  
**20P-2810L, 20V-2810L (Grvd)**

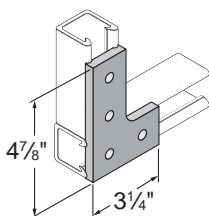

**20P-2512, 20V-2512 (Flat)**  
**20P-2812, 20V-2812 (Grooved)**

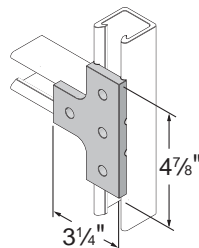

**20P-2514, 20V-2514 (Flat)**  
**20P-2814, 20V-2814 (Grooved)**

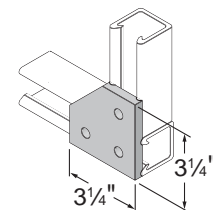

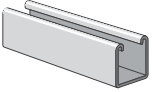

**20P-2516, 20V-2516 (Flat)**  
**20P-2816R, 20V-2816R (Grvd)**  
**20P-2816L, 20V-2816L (Grvd)**

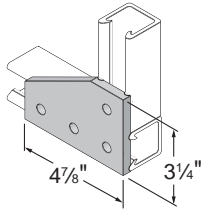

**20P-2518, 20V-2518 (Flat)**  
**20P-2818, 20V-2818 (Grooved)**

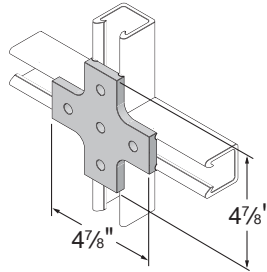

**20P-2520, 20V-2520 (Flat)**  
**20P-2820, 20V-2820 (Grooved)**

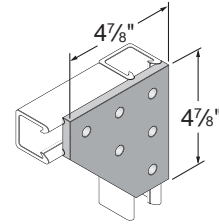

**20P-2522, 20V-2522 (Flat)**  
**20P-2822, 20V-2822 (Grooved)**

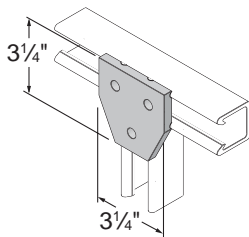

**20P-2524, 20V-2524 (Flat)**  
**20P-2824, 20V-2824 (Grooved)**

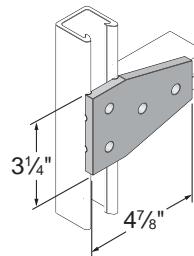

**20P-2526, 20V-2526 (Flat)**  
**20P-2826, 20V-2826 (Grooved)**

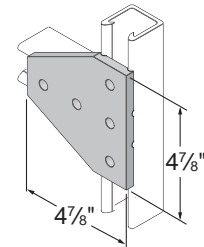

**20P-2528, 20V-2528 (Flat)**  
**20P-2828, 20V-2828 (Grooved)**

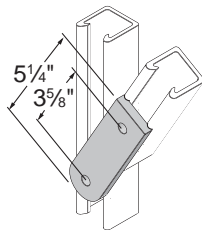

**20P-2530, 20V-2530 (Flat)**  
**20P-2830, 20V-2830 (Grooved)**

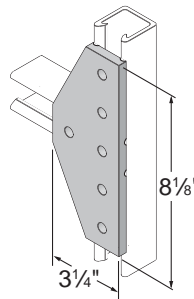

**20P-2534, 20V-2534 (Flat)**  
**20P-2834, 20V-2834 (Grooved)**

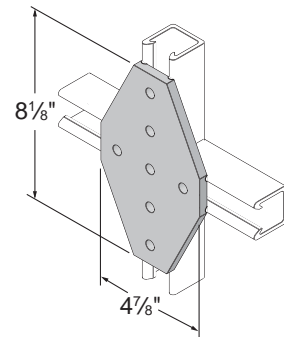

**20P-2541, 20V-2541 (Flat)**

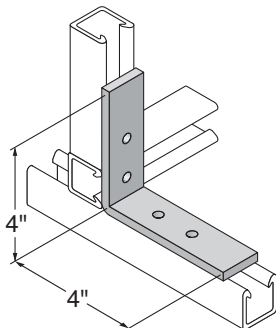

**20P-2540, 20V-2540 (Flat)**  
**20P-2840, 20V-2840 (Grooved)**

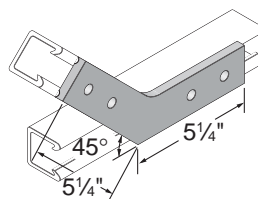

**50PU-2611 (Flat)**

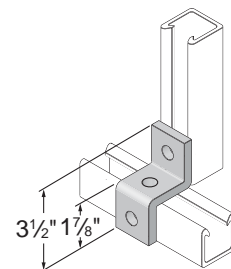



## Channel Fittings

### 20P-2542, 20V-2542 (Flat)

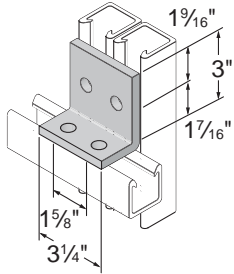

### 50PU-2611-SP

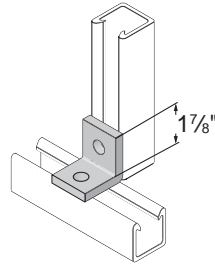

Note: 9/16" diameter holes

### 50PU-2613 (Flat)

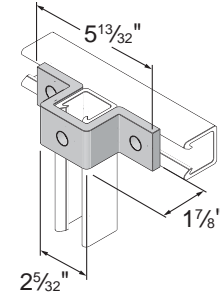

Note: 9/16" diameter holes

### 50PU-1508 (1 1/2") 50PU-2008 (1 5/8")

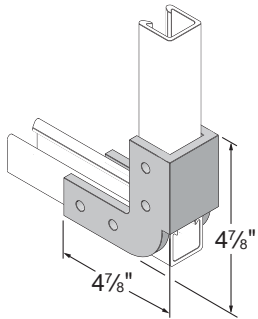

### 50PU-2045 (1 5/8")

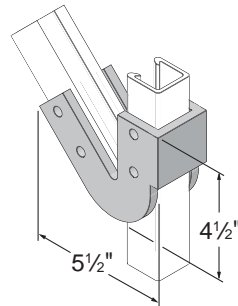

### 50PU-2090 (1 5/8")

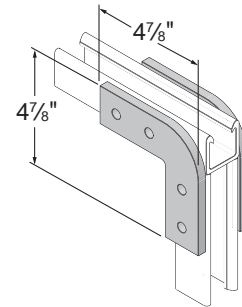

### 50PU-2636<sup>1</sup>, 50PU-2636A<sup>2</sup>, 50PU-2636B<sup>3</sup>, 50PU-2936<sup>4</sup>

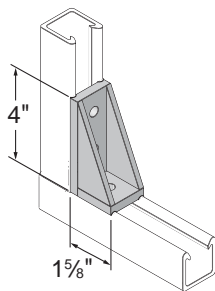

- 1) 50PU-2636 – Flat, without splines
- 2) 50PU-2636A – Splines on long side only
- 3) 50PU-2636B – Splines on short side only
- 4) 50PU-2936 – Splines on both long and short sides

### 50PU-2538 (Flat)

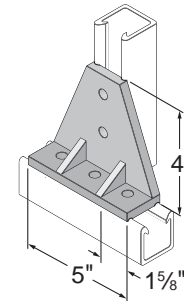

### 20PU-5853 (1 5/8"), 20PU-5854 (1 1/2"), 20PU-5855 (1 1/8"), 20PP-5853 (1 5/8"), 20PP-5854 (1 1/2"), 20PP-5855 (1 1/8")

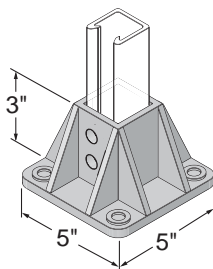

### 20PU-5903 (3 1/4"), 20PU-5904 (3"), 20PU-5905 (2 1/4"), 20PP-5903 (3 1/4"), 20PP-5904 (3"), 20PP-5905 (2 1/4")

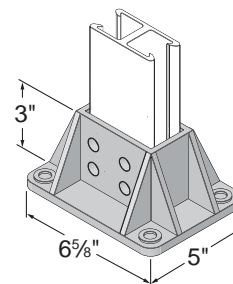

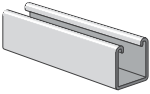

**Aickinclamps Design Load Information**

There are two types of piping system loadings, overhead (Type 1) and vertical (Type 2) as described below. All Aickinstrut pipe straps and clamps show the recommended loading for both types of loading.

**TYPE 1 DESIGN LOAD**

The design load shown represents pipes supported below the strut. The design loads shown are based on a minimum ultimate failure safety factor of 3:1.

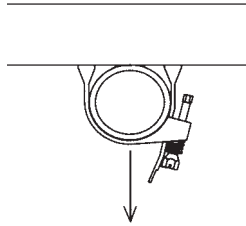

**TYPE 2 DESIGN LOAD**

The design loading shown can be achieved with the addition of a vertical stop lock assembly (Part #200-4219) installed directly beneath the pipe clamp. The adjacent illustration shows how the vertical stop lock assembly provides additional support for pipe and how it can be used to achieve full Type 2 design loads.

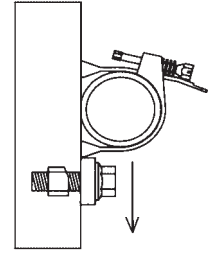

Design loads are based on a minimum clamp slip safety factor of 3:1. It is recommended that stop lock assemblies be used for all vertical pipe support applications.

**200-3100 thru 200-3210 – Adjustable Pipe Clamps**

Aickinstrut Adjustable Pipe Clamps are manufactured from glass-reinforced polyurethane and are adjustable to accommodate a wide range of outside diameters. They can be utilized with a variety of piping systems including: PVC, fiberglass, copper, rigid steel conduit and PVC coated rigid steel conduit. Aickinclamps sized 6 1/2" – 20" are to be used only in non-load bearing applications. These are applications where the weight of the pipe is being supported by Aickinstrut structural members (see figure on right). Aickinclamps

can safely be used in temperatures up to 160°F. For operating temperatures of 160-230°F, it is recommended to use PVDF clamps. PVDF clamps are available as a special order. Contact the factory for pricing and availability. Care should be taken not to exceed 3 ft./lbs. of torque on the adjustable pipe straps.

Part Number	O.D. Pipe Size (in.)	Design Load (lbs.)*		Torque (ft./lbs.)
		Type 1	Type 2	
200-3100	1/2 – 1 1/2	135	65	10 in./lbs.
200-3110	1 1/2 – 2 1/4			3
200-3120	2 1/4 – 3 1/4	145		
200-3130	3 – 4	215	70	
200-3140	4 – 6 1/2			

\*Design loads shown represent a 3:1 safety factor.

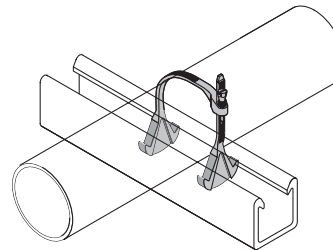

200-3100 to 200-3140

**50PU-500SP – Channel Spacers**

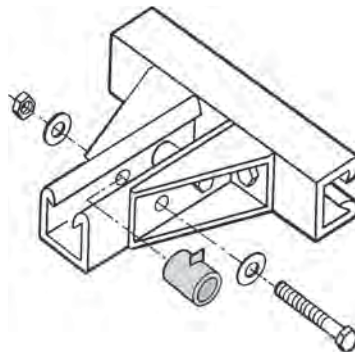
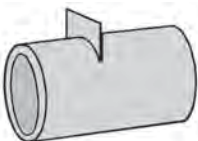

Channel spacers are designed to prevent wall compression under heavy loading conditions. Such loading occurs during the torquing of hardware for channel fittings. The spacers are molded from polyurethane and will accommodate 3/8" and 1/2" bolts. The spacers are designed to be used only with 1 5/8" and 1 1/2" channels.

## Pipe Clamps

### PCR – Rigid Pipe Clamps

Aickinstruct Rigid Pipe Clamps resemble the more traditional style of pipe clamps. These clamps are made from glass-reinforced polyurethane and are sized based on the pipe inside diameter or nominal size.

Polyurethane clamps are recommended for applications up to 160°F. For high temperature applications (up to 230°F), PVDF clamps are available as a special order. Contact the factory for pricing and availability.

Care should be taken not to exceed the recommended torque values of the rigid pipe clamps.

Part No.	Nominal Size (in.)	PVC Sch. 80 & Rigid Metal	Design Loads (lbs.)*		FRP Bolt Size (in.)	FRP Bolt Torque (ft./lbs.)
			Type 1	Type 2		
PCR-050	1/2	0.840	225	90	3/8 x 1/4	3
PCR-075	3/4	1.050				
PCR-100	1	1.315				
PCR-125	1 1/4	1.660				
PCR-150	1 1/2	1.900				
PCR-200	2	2.375				
PCR-250	2 1/2	2.875				
PCR-300	3	3.500				
PCR-400	4	4.500	300	125		
PCR-600	6	6.625				
PCR-800	8	8.625				

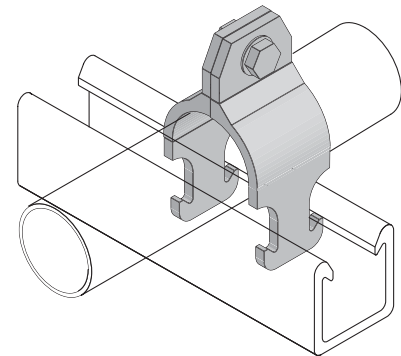

\*Design loads shown represent a 3:1 safety factor.

### PS050 thru PS 1800 – Two Hole Pipe Straps

Aickinstruct Two Hole Pipe Straps are designed for use in securing pipe, conduit and ducts to Aickinstruct Channel. Two hole fiberglass straps can also be used independently from the channel for surface mounting. All sizes of the straps are suitable for load bearing applications.

The two hole pipe straps are manufactured from a fire-retardant, glass reinforced polyester resin. For extreme chemical environments, the straps can be manufactured from vinyl ester resin. Larger diameter straps for special applications are also available. Contact the factory for pricing and availability of vinyl ester and large diameter straps. Two hole pipe straps should not be torqued above recommended values.

Part No.	Dimension		Bolt Size (in.)	Material Size (in.)	Design Load (lbs.)*		Torque (ft./lbs.)	
	A (in.)	B (in.)			Type 1	Type 2		
PS050	0.840	4.840	1/2	1/4 X 1 5/8	135	50	4	
PS075	1.050	5.050						
PS100	1.315	5.315						
PS150	1.900	5.900						
PS200	2 3/8	6.375						
PS250	2 7/8	6.875						
PS300	3 1/2	7.500						
PS350	4	8.000						
PS400	4 1/2	8.500						
PS500	5 9/16	9.563			175	60		
PS600	6 3/8	10.625			225	125		10
PS800	8 3/8	12.625						
PS1000	10 3/4	15.750						
PS1200	12 3/4	16.250						
PS1400	14	18.000	3/8 X 1 5/8	250	150			
PS1600	16	20.000	5/8	3/8 X 1 5/8	250	150		
PS1800	18	23.000						

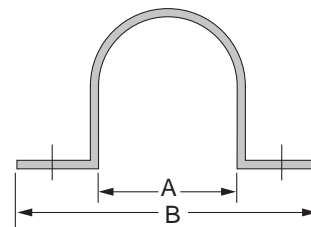
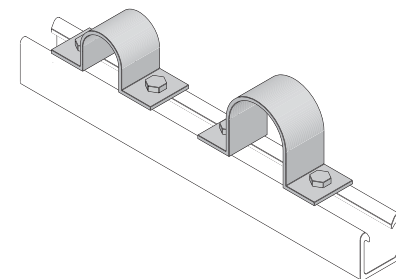

When bolting onto 1 5/8" or 1 1/2" channel a 1 1/4" long bolt is required.

\*Design loads shown represent a 3:1 safety factor.

Notes: Bolts and channel nuts are sold separately.

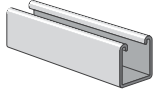

**PS TP - Aickin-A-Grip (SST Style Channel Only)**

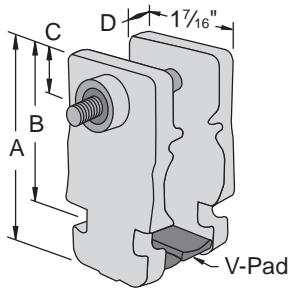

Part No.	Nominal Pipe Size	Dimensions (In.)				Hex Head Cap Screw & Lock Nut	Wt/100 pcs Lbs
		"A"	"B"	"C"	"D"		
PS TP-025	1/4	1 15/16	1 3/8	3/8	3/16	1/4-20 x 1 1/2"	4
PS TP-625	3/8	2 5/8	1 5/8	7/16	1/4		6
PS TP-875	1/2	2 9/16	1 13/16				5/16
PS TP-100	3/4	2 11/16	1 15/16		8		

Includes: Cushion, V-pad, and Hardware.  
 Materials: Cushion: Thermoplastic elastomer.  
 Hardware: Stainless Steel with Captured Nylon Locknut  
 Temperature Rating: -40°F to +275°F  
 Note: For use with SST Style Strut only

**Multi-Size Adjustment Capability**  
 Allows Four Clamp Sizes to Fit  
 Seventeen Sizes of Tube & Pipe.

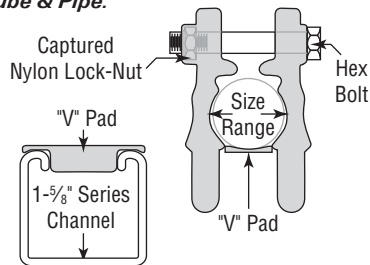

**FEATURE**

- Ten sizes of tube;  
 Five sizes of pipe...  
 Using just four sizes of clamp.
- Diameters from .25" to 1.31"
- Metric Sizes from 6mm to 32mm
- Non-Conducting
- Corrosion Resistant
- UV Resistant
- Temperature

**ADVANTAGE**

- Reduces Inventory SKU's
- Fewer parts needed on the job.
- Simplifies take-offs & component requirements on projects using both Tube & Pipe Sizes
- High pull out and slip loads

**BENEFIT**

- Lowers Inventory Costs.
- Always have the right clamp on hand when you need it.
- Job Costing made easier & more accurate.

**Tube Sizes**

Part No.	O.D. Tube Sizes			Diameters	PullOut Load/Lbs	Slip Load/Lbs
PS TP-025	1/4	3/8	1/2	0.25 - 0.54		
PS TP-625	5/8	3/4	7/8	0.62 - 0.87		
PS TP-875	7/8	1	1 1/8	0.87 - 1.12		
PS TP-100	1	1 1/8	1 1/4	1.00 - 1.31		

**Pipe Sizes**

Part No.	Nominal Pipe Sizes	Diameters	PullOut Load/Lbs	Slip Load/Lbs
PS TP-025	1/4	-		
PS TP-625	3/8	1/2		
PS TP-875	3/4	-		
PS TP-100		1		

Nominal Pipe Size	Water Filled Weight (lbs/ft)	Code Required Support Spacing <sup>(3)</sup> (ft)	Pipe Load At Support (lbs)	Safety Factors from Allowed Value	
				Pullout	Slip
(Sch 40) 1/4"	0.470	7	3	150	12
3/8"	0.651		5	110	9
1/2"	0.983		7	70	6
3/4"	1.361		10	50	4
1"	2.055		14	30	3

<sup>(1)</sup> Based on preliminary testing  
<sup>(2)</sup> SF = 5 to Ultimate Load  
<sup>(3)</sup> Per MSS-SP69 & ASME B31.1 for water filled pipe

**20E-5000 - Channel Capping Strip**

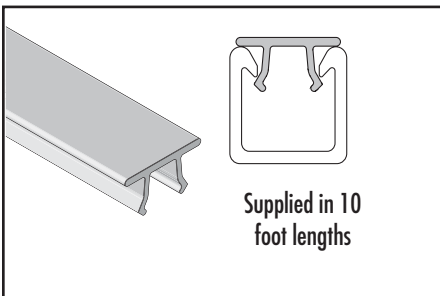

Channel Capping Strip is made from PVC and installs simply by pressing it onto the channel opening. It is designed to be used when a cover is desired for the channel opening (such as concrete embedment channel).

**AIC-EC - Channel End Cap**

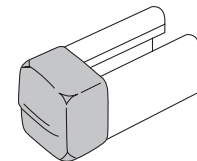

The Aickin-End Cap is made from red PVC and designed for 1 5/8" channel. End caps are desired when the ends of the channel need to be enclosed. The Aickin-End Cap easily installs by pressing it onto the end of the channel opening.

Metal Channel  
Fasteners  
Fittings  
Pipe & Conduit Clamps  
Electrical  
Concrete Inserts  
Solar Components  
Unipier®  
Jr. Channel  
Power-Angle  
Fiberglass  
Tech. Data

## Pipe Clamps

### UB-050 thru UB-600 - Nonmetallic U-bolts

Aickinstruct Nonmetallic U-Bolts provide a corrosion resistant alternative to traditional metallic U-Bolts. Made from glass-reinforced polyurethane, these bolts will outlast stainless steel in most corrosive applications. Nonmetallic U-Bolts have oversized diameters which allow them to hold steel conduit and plastic pipe.

Each U-Bolt comes with two polyurethane hex nuts. Additional nuts and washers can be purchased separately.

The U-Bolts can also be installed to allow for thermal expansion and contraction of plastic pipe as shown here.

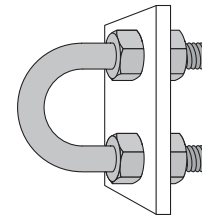

Note: Plate not included. Illustration purpose only

Part No.	Size	"A"	"B"	"C"	"D"	"TL"	Load (lbs.)*	Torque (in./lbs.)*
UB-050	1/2	0.937	0.375	1.568	2.412	1.25	135	40
UB-075	3/4	1.125		1.662	2.600			
UB-100	1	1.375		1.787	2.850			
UB-125	1 1/4	1.687		1.943	3.162			
UB-150	1 1/2	2.000		2.100	3.475			
UB-200	2	2.437	0.500	2.468	4.187	1.50	80	
UB-250	2 1/2	2.937		2.718	4.687			
UB-300	3	3.562		3.031	5.312			
UB-350	3 1/2	4.062		3.281	5.812			
UB-400	4	4.562		3.531	6.312			
UB-600	6	6.750		0.625	5.750			9.875

\*Torque and load values shown represent a 3:1 safety factor.

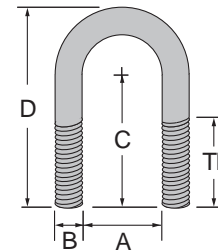

### Fiberfast Bolts

Fiberfast bolts are provided in two styles and five diameters (1/4", 3/8", 1/2", 5/8" and 3/4") and range in length from 1 1/4" to 3 1/2". The flanged style incorporates a molded washer collar which eliminates the need for a washer. The flanged style is provided for 1/4" and 1/2" diameter bolts. Flanged bolts are available in 3/8" diameter as a special order item. The hex head style is provided for all 3/8", 5/8" and 3/4" diameter bolts. All Fiberfast bolts are not fully threaded, therefore, shoulder

length (nonthreaded portion) dimensions have been provided. Fiberfast bolts are ideal for mechanical connections that require a high degree of corrosion resistance. The 3/8" diameter fasteners are recommended for all channel fitting mechanical connections. All Fiberfast bolts are manufactured from glass-reinforced polyurethane and are packaged in bags containing 25 pieces.

#### 250PU - Hex Flange Bolts

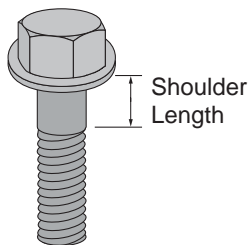

Part No.	Size	Thread Shear (lbs.)*	Shank Shear (lbs.)*	Shoulder Length	Torque (ft./lbs.)
250PU-075	1/4 x 3/4	110	210	Full Thread	10 In./lbs.
250PU-100	1/4 x 1			1/2	
250PU-150	1/4 x 1 1/2			1/2	
500PU-125	1/2 x 1 1/4			1/2	
500PU-150	1/2 x 1 1/2	450	870	Full Thread	8
500PU-200	1/2 x 2			3/4	
500PU-250	1/2 x 2 1/2			1	
500PU-300	1/2 x 3			1	
500PU-350	1/2 x 3 1/2			2 3/16	

\*Thread shear values shown represent a 3:1 safety factor.

#### 375PU - Hex Bolts

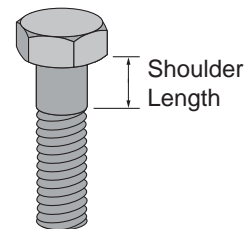

Part No.	Size	Thread Shear (lbs.)*	Shank Shear (lbs.)*	Shoulder Length (in.)	Torque (ft./lbs.)
375PU-125	3/8 x 1 1/4	250	470	Full Thread	3
375PU-150	3/8 x 1 1/2			1/4	
375PU-200	3/8 x 2			1/2	
375PU-250	3/8 x 2 1/2			3/4	
375PU-300	3/8 x 3			1	
625PU-125	5/8 x 1 1/4	700	1,360	1/4	12
625PU-150	5/8 x 1 1/2				
625PU-200	5/8 x 2				
625PU-250	5/8 x 2 1/2			1/4	
625PU-300	5/8 x 3				
625PU-350	5/8 x 3 1/2				

\*Thread shear values shown represent a 3:1 safety factor.

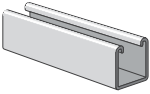

Metal Channel  
Fasteners  
Fittings  
Pipe & Conduit Clamps  
Electrical  
Concrete Inserts  
Solar Components  
Unipier®  
Jr. Channel  
Power-Angle  
Fiberglass  
Tech. Data

**375V - Vinyl Ester Square Head Bolts**

Vinyl ester square head bolts are used for concrete mounting and general purpose fastening applications. The square head bolts are constructed from vinyl ester all-thread rod and vinyl ester square nuts. The units are bonded together with a durable two part urethane adhesive. The square head bolts are offered in 3/8" diameter but can be supplied in other diameters as a special order. Contact the factory for pricing and availability of special diameter square head bolts.

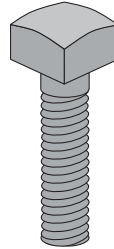

Part No.	Size	Thread Shear (lbs.)*	Torque (ft./lbs.)*
375V-100	3/8 x 1	250	10
375V-125	3/8 x 1 1/4		
375V-150	3/8 x 1 1/2		
375V-175	3/8 x 1 3/4		
375V-200	3/8 x 2		
375V-250	3/8 x 2 1/2		
375V-300	3/8 x 3		
375V-350	3/8 x 3 1/2		
375V-400	3/8 x 4		

\*Thread shear values shown represent a 3:1 safety factor.

**Fiberfast Hex Nuts**

Aickinstruct hex nuts are available in two styles; hex and hex flange nuts. The Aickinstruct hex nut is similar in design to the conventional hex nut and is preferred for channel fitting connections. The Aickinstruct hex flange nut is preferred for applications that require additional thread engagement (such as with all-thread rod) or maximum thread shear strength. All nuts are

manufactured from glass-reinforced polyurethane and are packaged in bags containing 25 pieces. All hex and hex flange nuts are available in PVDF and Polypropylene and metric sizes as a special order. Contact the factory for pricing and availability.

**250PU thru 1000PU - Hex Nuts**

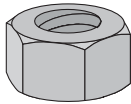

Part No.	Size	Thread Shear (lbs.)*	Height	Torque (ft./lbs.)
250PU-000	1/4-20	150	0.218	10 in./lbs.
375PU-000	3/8-16	460	0.328	3
500PU-000	1/2-13	800	0.437	8
625PU-000	5/8-11	1,000	0.546	12
750PU-000	3-10		0.640	15
1000PU-000	1-8		0.859	17

\*Thread shear values shown represent a 3:1 safety factor.

**375PU thru 1000PU - Hex Flange Nuts**

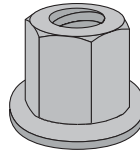

Part No.	Size	Thread Shear (lbs.)*	Height	Torque (ft./lbs.)
375PU-FN-000	3/8-16	500	0.750	3
500PU-FN-000	1/2-13	1,200	0.855	8
625PU-FN-000	5/8-11	2,200	1.220	12
750PU-FN-000	3/4-10	2,900	1.590	15
1000PU-FN-000	1-8		1.750	17

\*Thread shear values shown represent a 3:1 safety factor.

**375V thru 1000V - Vinyl Ester Square Nuts**

Square nuts are manufactured from pultruded vinyl ester square stock. They are recommended for applications that require high thread shear values. Square nuts are packaged in bags containing 25 pieces.

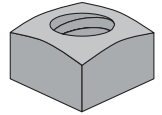

Part No.	Size	Thread Shear (lbs.)*	Height	Torque (ft./lbs.)
375V-000	3/8-16	1,300	0.437	10
500V-000	1/2-13	1,700	0.562	
625V-000	5/8-11		0.687	
750V-000	3/4-10		0.812	
1000V-000	1-8		0.937	

\*Thread shear values shown represent a 3:1 safety factor.

**250E thru 1000E - Flat Washers**

Flat Washers are made from PVC and are available for 1/4" diameter through 1". PVC washers are recommended for connections that utilize hex nuts and bolts. PVC washers are packaged in bags containing 25 pieces.

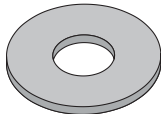

Part No.	Size	Outside Diameter
250E-999	1/4	0.49
375E-999	3/8	1.00
500E-999	1/2	1.25
625E-999	5/8	1.50
750E-999	3/4	1.50
1000E-999	1	2.25

**WR375 thru WR750 - All-Thread Washers**

Aickinstruct All-Thread Washers are flat fiberglass washers for use with FRP all-thread rods. All-Thread rod washers are 1/4" thick with a 1 1/8" diameter and are available in polyester or vinyl ester resin. To order vinyl ester, add the suffix "V" to the part number. To order square washers add the suffix "-SQ" to the part number.

Part No. *	All-Thread Rod Size (in.)
WR375	3/8
WR500	1/2
WR625	5/8
WR750	3/4

\* Add the suffix "V" to the part number to specify vinyl ester Example "WR500V"

\* Add the suffix "-SQ" to the part number to specify square washer Example "WR500-SQ"

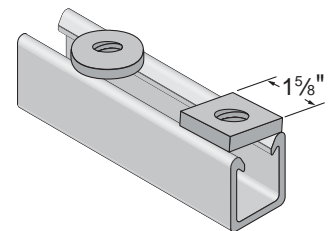

## Fasteners

### Channel Nuts

Channel nuts are provided in two types; Standard Duty and Heavy Duty. Standard Duty channel nuts are designed for light duty applications that do not require high thread shear values. Standard duty channel nuts can also be used with all sizes of Aickinstrut Channel. Heavy duty channel nuts are designed to be used where high thread shear values or spring nuts

are required. Heavy duty channel nuts can not be used with Series 1000 Channel (light duty). All channel nuts are manufactured from glass-reinforced polyurethane and are packaged in bags containing 50 pieces. Channel nuts are also available in PVDF as a special order. Contact the factory for pricing and availability.

#### 375PU-CNHD thru 750PU-CNHD, 10PU-CNMHD thru 20PU-CNMHD - HD Channel Nuts

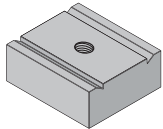

Part No.	Size	Thread Shear (lbs.)*	Torque (ft./lbs.)
375PU-CNHD	3/8-16	1,400	8
500PU-CNHD	1/2-13		10
625PU-CNHD	5/8-11		8
750PU-CNHD	3/4-10		10
10PU-CNMHD	10 mm		8
12PU-CNMHD	12 mm		10
16PU-CNMHD	16 mm		
20PU-CNMHD	20 mm		

\*Thread shear values shown represent a 3:1 safety factor.

#### 250PU-CN thru 500PU-CN , 10PU-CN thru 12PU-CN - Standard Duty Channel Nuts

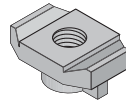

Part No.	Size	Thread Shear (lbs.)*	Torque (ft./lbs.)
250PU-CN	1/4-20	460	2
312PU-CN	5/16-18		3
375PU-CN	3/8-16		N/A
500PU-CN	1/2-13		
10PU-CN	10 mm		
12PU-CN	12 mm		
10PU-CNS	#10 Screw		

\*Thread shear values shown represent a 3:1 safety factor.

### 200-4266 thru 200-3442 - Saddle Clips

Aickinstrut Saddle Clips make fastening through Aickinstrut channel much easier. The clips mate with the exterior of the channel flanges and are secured with threaded rods and nuts. The saddle clips are manufactured from glass reinforced polyurethane and are supplied in bags of 50 pieces.

Part No.	Size
200-4226	3/8
200-4217	1/2
200-4341	5/8
200-4342	3/4

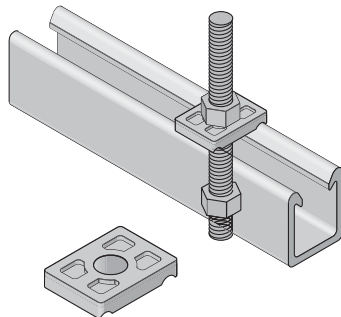

### 200-4277, 200-4219, 200-4343 - Stop-Lock Assemblies

Aickinstrut Stop-Lock Assemblies reduce the chance of pipe slippage when running supports vertically. Stop-Locks are recommended for applications that are subject to vibration, have regular contact with fluids or are vertically mounted (Type 2). The Stop-Locks fit all three sizes of channel. Stop-Locks are offered with a 3/8", 1/2" and 5/8" bolt size. The 3/8" Stop-Lock Assembly is supplied with a heavy duty channel nut (the 5/8" Stop-Lock Assembly will not work with the 1000 Series Channel).

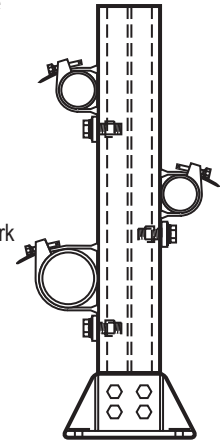

The Stop-Lock Assemblies' components are manufactured from glass-reinforced polyurethane.

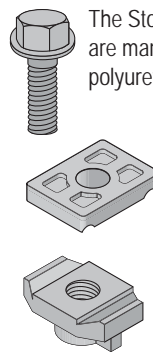

Part No.	Size	Force Resistance (lbs.)*	Torque (ft./lbs.)
200-4227	3/8	200	7
200-4219	1/2	220	12
200-4343	5/8	250	15

\*Force resistance values shown represents a 3:1 safety factor.

### 20V-2BC - Fabricated Beam Clamps

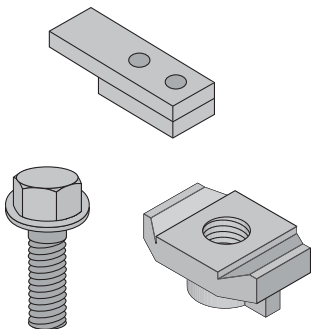

Part No.	Flange Thickness	Thread Shear (lbs.)*	Torque (ft./lbs.)
20V-2BC-25	1/4	600	10
20V-2BC-37	3/8		
20V-2BC-50	1/2		

\*Design load values shown represent a 3:1 safety factor. Bolts and channel nuts are 1/2" diameter.

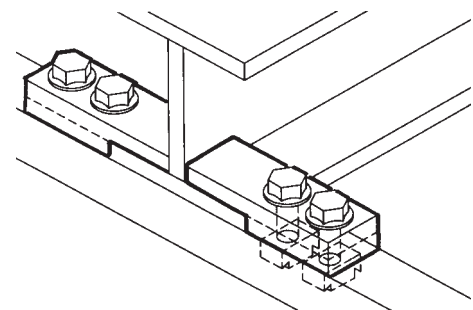

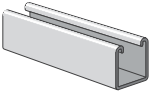

Metal Channel  
Fasteners  
Fittings  
Pipe & Conduit Clamps  
Electrical  
Concrete Inserts  
Solar Components  
Unipier®  
Jr. Channel  
Power-Angle  
Fiberglass  
Tech. Data

**Clevis Hangers**

Clevis hangers are available in two styles; molded and hand lay-up. The molded clevis hangers are manufactured from glass-reinforced polyurethane and are available for sizes 1/2" through 6". The hand lay-up clevis hangers are manufactured from glass-reinforced vinyl ester resin and are available for sizes 1" through 24".

**CVHPU - Molded Clevis Hangers**

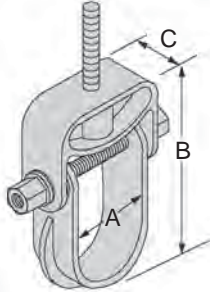

Part No.	Nominal Diameter	Max. Pipe O.D.	"A"	"B"	"C"	Hanger Rod	Load (lbs.)*
CVHPU-100	1/2 - 1	1	1.500	4.25	1.25	1/2	670
CVHPU-150	1 1/4 - 1 1/2	1 1/2	2.000	5.14			730
CVHPU-200	1 1/2 - 2	2	2.500	6.52			1,150
CVHPU-400	2 1/2 - 4	4	5.125	10.00	1.50	1/2	1,170
CVHPU-600	4 1/2 - 6	6	6.750	12.33			1,170

\*Design load values shown represent a 3:1 safety factor.

**100-1500 thru 100-1514 - Hand Lay-Up Clevis Hangers**

Part No.	Size Range A (In.)	Dimensions (in.)				Hanger Rod	Trans Rod	Spreader Rod O.D.	Loads (lbs.)*
		T	H	H1	W				
100-1500	1 - 1 1/2	1/8	2 3/4	1 7/8	1 1/2	1/2	3/8	1/2	60
100-1501	1 1/2 - 2		3 1/2	2 5/8					60
100-1502	2 - 2 5/8		4 3/4	3	2				90
100-1503	2 1/2 - 3 1/4		5 1/2	3 5/8					120
100-1504	3 - 3 3/8	1/8	7	4 1/4	2	5/8	1/2	160	
100-1505	4 - 5 1/8	3/16	8 1/2	5 5/8				250	
100-1506	6 - 7 1/8		10 7/8	7 1/2	3			300	
100-1507	8 - 9 1/4		1/4	14				9 3/4	350
100-1508	10 - 11 3/8	1/4	18	12	4	5/8	1/2	3/4	450
100-1509	12 - 13 1/2		21 1/2	14 1/8					5
100-1510	14 - 15 3/4		24 1/2	16 1/2	700				
100-1511	16 - 18	3/8	27 3/8	19 1/2	6				3/4
100-1512	19 - 21		34 1/2	22 1/2		800			
100-1513	21 - 22	1/2	35 1/2	24	6	850			
100-1514	22 - 24		41	28		900			

\*Design load values shown represent a 3:1 safety factor.

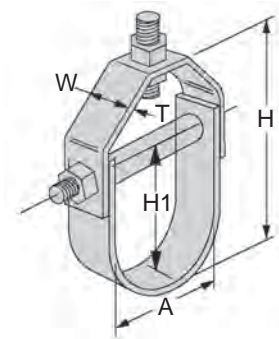

**Beam Clamps**

Aickinstrut beam clamps are available in two styles; molded and fabricated. The molded beam clamps are manufactured from glass-reinforced polyurethane and can accommodate 3/8", 1/2" and 5/8" hanger rod sizes. The molded beam clamps utilize the traditional "C" clamp style design. The fabrication beam clamps are manufactured from vinyl ester flat stock and utilize polyurethane bolts and channel nuts for clamping. Fabricated beam clamps are available for attaching to 1/4", 3/8" and 1/2" thick beam flanges. Each fabricated beam clamp assembly includes four (4) 1/2" standard duty channel nuts, four (4) 1/2" Polyurethane bolts and two (2) attachment clips. All Aickinstrut beam clamps allow easy attachment of threaded rod to "I" beams or other structural assemblies.

**375PU-BC, 500PU-B - Molded Beam Clamps**

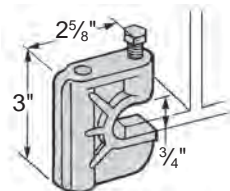

Part No.	Size	Thread Shear (lbs.)*	Torque (ft./lbs.)
375PU-BC	3/8	400	10
500PU-BC	1/2		

\*Design load values shown represent a 3:1 safety factor.

**RGBC - Beam Clamps**

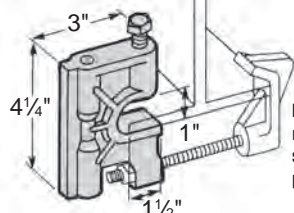

Note: Beam clamp clip must be purchased separately. Illustration purpose only

Part No.	Size	Thread Shear (lbs.)*	Torque (ft./lbs.)
RGBC-1	3/8	500	10
RGBC-2	1/2		
RGBC-3	5/8		

**Beam Clip - 375PU-BCCLP (3/8")**





## Pipe Supports

### 200-327 thru 200-3831 - Threaded Rod

Pultruded threaded rods are an excellent choice for hanging and fastening Aickinstruct Channel. These rods can also be used with either the Aickinstruct vinyl ester square nuts, polyurethane hex nuts, hex flange nuts and Aickinstruct channel nuts. All FRP threaded rod is manufactured from pultruded vinyl ester resin and is gray in color.

The standard rod lengths are 4' and 8'. Special lengths and threading are also available. Contact the factory for pricing and availability.

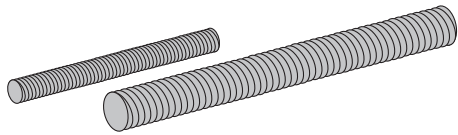

Part No.	Size	Weight	Thread Shear (lbs.)*	Torque (ft./lbs.)
200-3827	3/8-16	0.07	415	5
200-3828	1/2-13	0.12	570	10
200-3829	5/8-11	0.18	1,260	40
200-3830	3/4-10	0.28	1,700	50
200-3831	1-8	0.50	3,000	60

\* Thread shear values shown represent a 3:1 safety factor.  
 \* To order eight foot lengths, add suffix "-96" to part number (EX: 200-3827-96)

### 200-3849 thru 200-3843 - A-Konnector Rod Couplers

A-Konnectors provide an excellent means for extending Aickinstruct FRP all-thread rods beyond their standard lengths. A-Konnectors are manufactured from glass-reinforced polyurethane and are colored gray. A-Konnectors are packaged in bags containing 25 pieces.

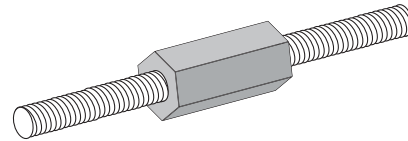

Part No.	Size	Length	Thread Shear (lbs.)*
200-3840	3/8-16	2 1/4	800
200-3841	1/2-13		870
200-3842	5/8-11		1,500
200-3843	3/4-10		

\* Thread shear values shown represent a 3:1 safety factor.

### 390N - Duraclamp C-Clamps

Duraclamps are glass-reinforced polyurethane C-Clamps that are designed to replace steel C-Clamps in areas where corrosion is a problem. The individual Duraclamp components can also be purchased separately.

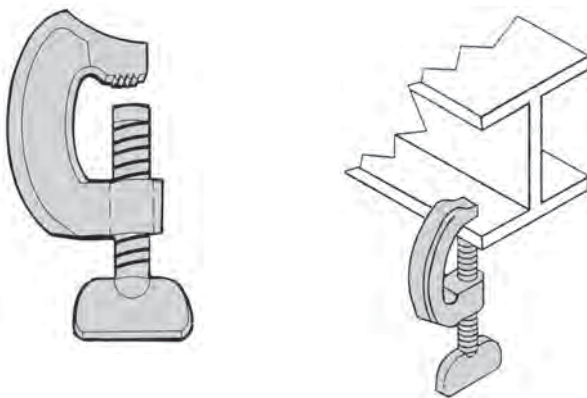

Part No.	Description	Thread Shear (lbs.)*	Torque (ft./lbs.)
390N-150	"C"-Clamp	25	17
390N-BLT	Bolt	N/A	
390N-CLP	"C"	25	N/A

\*Design load values shown represent a 3:1 safety factor.

Note: Bolt Dimension is 5/8" x 2 1/2"

### Channel Hangers

AIC-CH-P (Polyester)  
 AIC-CH-V (Vinyl Ester)

The Aickin-Channel Hanger is designed to support fiberglass structural "C" channel that is being used as a raceway system for cables, tubing or small diameter piping. The Aickin-Channel Hanger is available in either polyester or vinyl ester resin and is simply supported from a 1/2" FRP all-thread rod and beam clamp (not provided). The Channel Hanger will accommodate "C" channel width sizes 2" through 8".

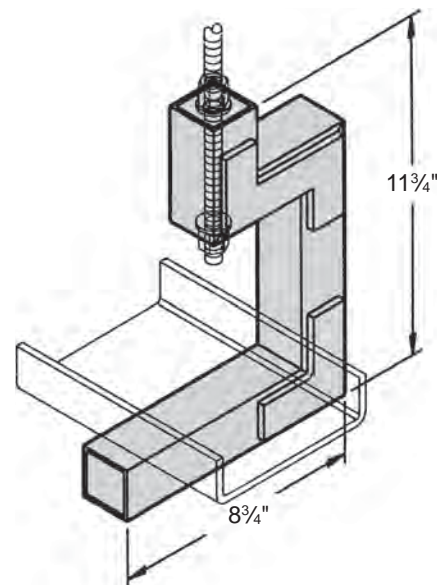

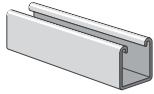

Metal Channel  
Fasteners  
Fittings  
Pipe & Conduit Clamps  
Electrical  
Concrete Inserts  
Solar Components  
Unipier®  
Jr. Channel  
Power-Angle  
Fiberglass  
Tech. Data

**20N-ARM, 20NSTA - Power-Rack Stanchions**

The Power-Rack Stanchion is the new alternative to traditional iron cable stanchions used for utility and industrial cable supports. Made entirely from glass-reinforced nylon, these stanchions out-perform metallic supports against corrosion. The extended life-span of the Power-Rack Stanchions makes them the logical choice over metallic cable supports. The Power-Rack Stanchion is available in two different lengths and four different arm lengths. The unique interlocking design allows the arm to "lock" into nine different levels on the 14<sup>1</sup>/<sub>4</sub>" stanchions and fourteen on the 17<sup>1</sup>/<sub>2</sub>" stanchion. Glass-reinforced polyurethane stanchions are available as a special order. Contact the factory for pricing and availability.

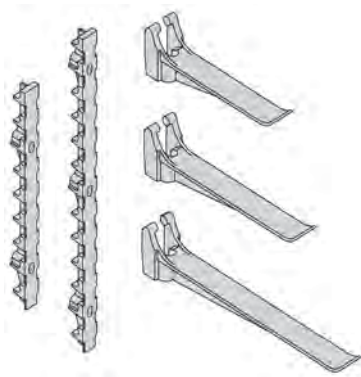

**Dimensions** – The stanchion back is designed with <sup>9</sup>/<sub>16</sub>" wide x <sup>15</sup>/<sub>16</sub>" long holes to accept fasteners for mounting. There are two mounting holes in the 21<sup>3</sup>/<sub>8</sub>" long stanchion and three mounting holes in the 33<sup>5</sup>/<sub>16</sub>" long stanchion. Thickness at the slotted mounting holes is <sup>1</sup>/<sub>8</sub>". The mounting holes are spaced on 12" centers and require <sup>1</sup>/<sub>2</sub>" diameter fasteners.

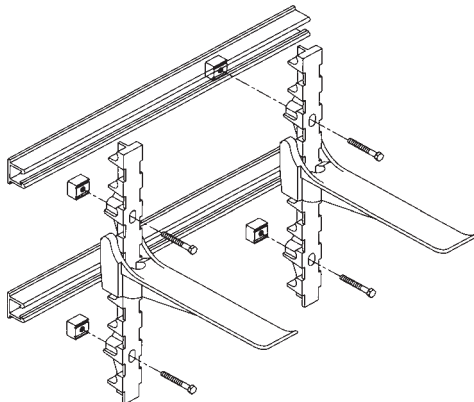

**Installation** – The Power-Rack Stanchions can be anchored into existing concrete structures using any good quality industrial anchoring system. For new concrete structures, the Power-Rack Stanchions can be mounted to Aickinstruct concrete embedment channel and attached with <sup>1</sup>/<sub>2</sub>" channel nuts and <sup>1</sup>/<sub>2</sub>"x 3" Fiberfast Bolts.

**Fire Retardance** – Power-Rack materials meet or exceed the requirements of UL94 HB.

**Loading** – The recommended allowable loads on Power-Rack Stanchions vary depending upon the position of the arm. Following the guidelines listed below will ensure a safe, reliable installation.

- Total load on any one arm should not exceed 800 lbs.
- The sum of the loads on any arm multiplied by their distances to the wall stanchion should not exceed 1200 in./lbs.

**Example** – A cable weighing 200 lbs. is positioned on an arm at a distance of 5" from the wall stanchion.

If the total load is less than 800 lbs and the sum of the load multiplied by their distances to the wall stanchion does not exceed 1200 in./lbs., then the system is adequate. In this case,

Total load (200<800 lbs) = OK

Tot. moment (200x5 in. = 1000<1200 in./lbs.) = OK

Part No.	Description	Weight	Load (lbs.)*
20N-ARM08	8" Arm	1.00	800
20N-ARM14	14 <sup>1</sup> / <sub>4</sub> " Arm	1.16	
20N-ARM17	17 <sup>1</sup> / <sub>2</sub> " Arm	1.45	
20N-ARM23	23 <sup>7</sup> / <sub>8</sub> " Arm	1.86	
20N-STA21	21 <sup>3</sup> / <sub>8</sub> " Stanchion	1.49	N/A
20N-STA33	33 <sup>5</sup> / <sub>16</sub> " Stanchion	2.31	

\*Design load values shown represent a 3:1 safety factor.

**Wall Brackets**

Aickin-Brackets are available in a wide variety of sizes and configurations. These wall brackets are made entirely from Aickinstruct material and are specifically designed to meet the customers requirements. They are ideal for customizing the support of piping, cables, tubing, conduits or cable trays. These brackets are available in either polyester or vinyl ester resin types and will work with all the Aickinstruct accessory items. Consult the factory for design, pricing and availability information.

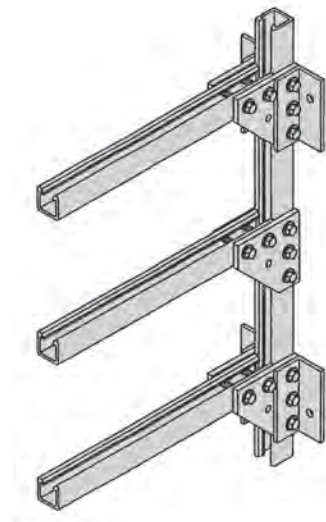

## Instrument & Pipe Stands

### Heavy Duty Post Base

20PU-5852 (2" Square), 20PU-5852 RD (2" Round)  
20PU-5853 HD (1<sup>5</sup>/<sub>8</sub>" Sq.), 20PU-5854 HD (1<sup>1</sup>/<sub>2</sub>" Sq.)

The Aickinstrut heavy duty post base is designed for applications that require a stronger base attachment than the standard Aickinstrut post base. Made from polyurethane, the heavy duty post base is available with four different openings: 1<sup>1</sup>/<sub>2</sub>", 1<sup>5</sup>/<sub>8</sub>", 2" square and 2" Schedule 80 round. The heavy duty post base is ideal for mounting fiberglass channel, handrails and instrument stands in corrosive environments. The standard color is gray, but special colors are available upon request.

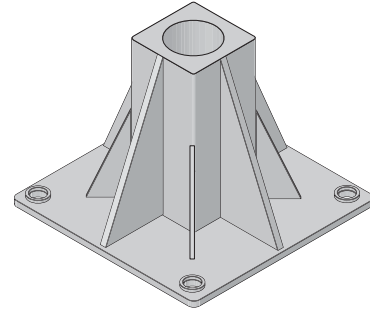
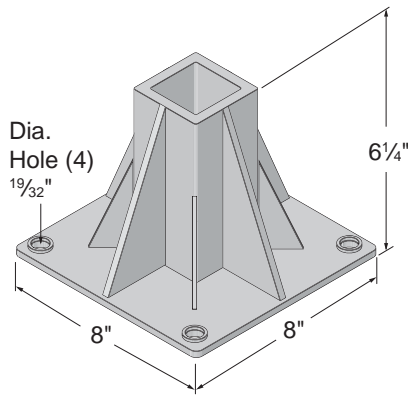

### Instrument & Pipe Stands

Aickin-Instrument and Pipe Stands are available in polyester or vinyl ester resin types and are designed to meet specific customer requirements. These stands are ideal for supporting instruments and enclosures in corrosive environments. The stands utilize the Aickinstrut Heavy Duty Post Base and either 2" x 2" x 1/4" square tube or 2" Schedule 80 pipe to support the instruments or enclosures. These stands can be designed or configured to meet any application. Consult the factory for design, pricing and availability information.

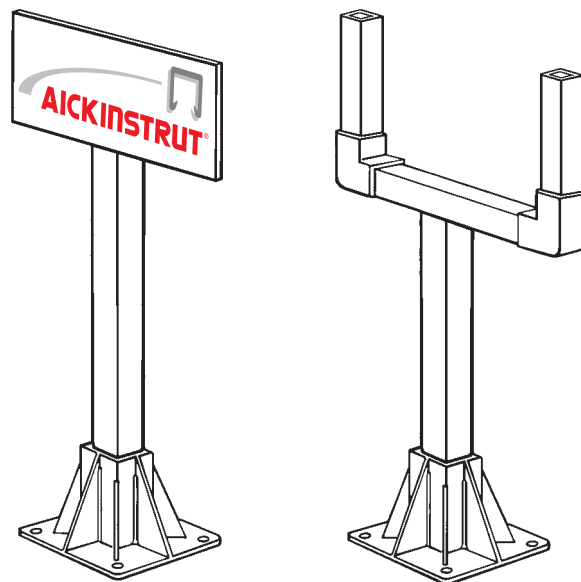

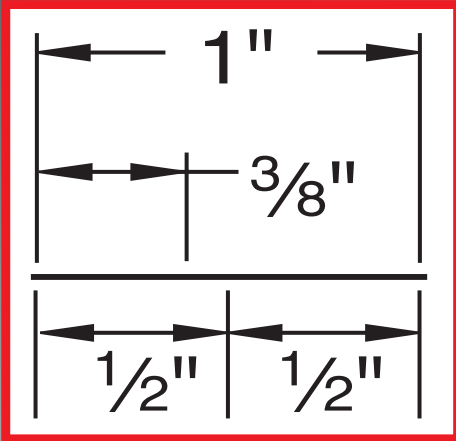
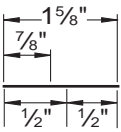

## TECHNICAL DATA

### Beam Diagrams and Formulas:

- Nomenclature
- Cantilever Beams
- Simple Beams
- Beams fixed at one end, supported at other
- Beams fixed at both ends

### Beam Load (Static) Conversion Factors

### Design Load Data For Power-Strut Channel Connections

### Pipe Spacing Tables

### NFPA 13 Compliance Tables

### Section Modulus Required for Trapeze Members

### Electrical Metallic Tubing Data

### Conduit Spacing

### Conduit & Pipe Data

- Steel Rigid
- Intermediate Metal
- Steel Pipe
- Copper Tube
- Cast Iron
- PVC

### Spacing of Hangers:

- Copper Tubing
- Steel Pipe
- PMC Plastic Pipe

### Load Tables

- Threaded Hot Rolled Steel Rod
- Wide Flange Beams
- Channels – American Standard
- I-Beams – American Standard

### Unit Conversions

### Part Number Index

The information presented below is a direct reproduction from portions of the 8th Edition of THE MANUAL OF STEEL CONSTRUCTION by express permission of the American Institute of Steel Construction.

## Beam Diagrams and Formulas (Nomenclature)

- E** Modulus of Elasticity of steel at 29,000 ksi.
- I** Moment of Inertia of Beam (inch<sup>4</sup>).
- Mmax** Maximum Moment (kip inch)
- M1** Maximum moment in left section of beam (kip inch)
- M2** Maximum moment in right section of beam (kip inch)
- Mx** Moment at distance x from end of beam (kip inch)
- P** Concentrated Load (kips)
- R** End beam reaction for any condition of symmetrical loading (kips)
- R1** Left end beam reaction (kips)
- R2** Right end or intermediate beam reaction (kips)
- V** Maximum vertical shear for any condition of symmetrical loading (kips)
- V1** Maximum vertical shear in left section of beam (kips)
- V2** Vertical shear at right reaction point, or to left of intermediate reaction point of beam (kips)
- Vx** Vertical shear at distance x from end of beam (kips)
- a** Measured distance along beam (inch)
- b** Measured distance along beam which may be greater or less than "a" (inch)
- L** Total length of beam between reaction points (inch)
- W** Uniformly distributed load per unit of length (lbs)
- x** Any distance measured along beam from left reaction (inch)
- x1** Any distance measured along overhang section of beam from nearest reaction point(in).
- Δmax** Maximum deflection (inch)
- Δa** Deflection at point of load (inch)
- Δx** Deflection at point x distance from left reaction (inch)

## Beam Diagrams and Formulas (Cantilever Beams)

### CANTILEVER BEAMS

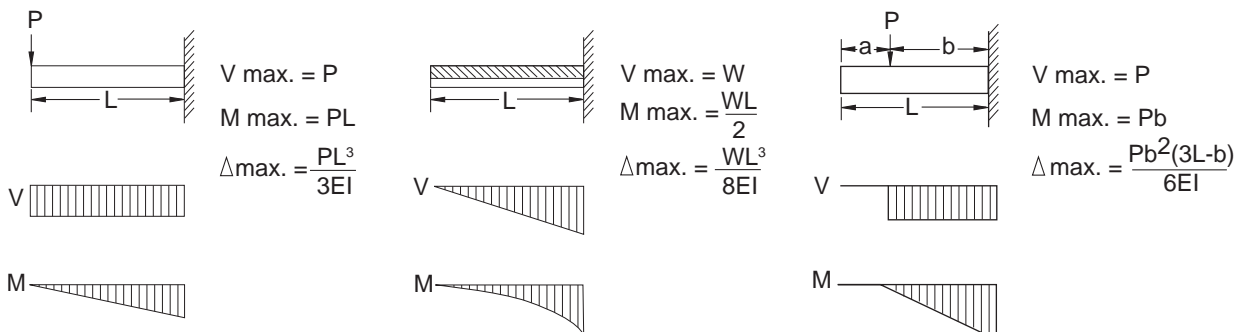

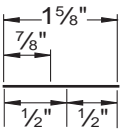

The information presented below is a direct reproduction from portions of the 8th Edition of THE MANUAL OF STEEL CONSTRUCTION by express permission of the American Institute of Steel Construction.

**Beam Diagrams and Formulas (Simple Beams)**

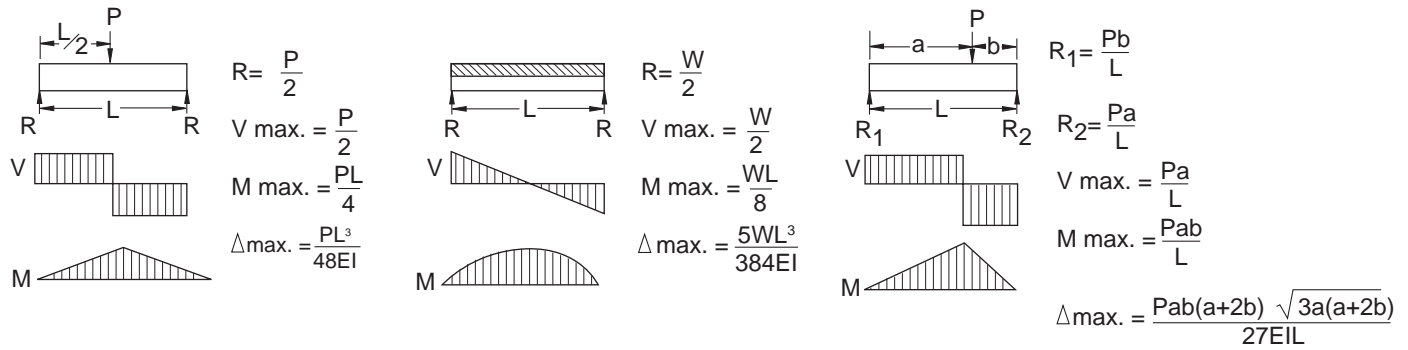

**Beam Diagrams and Formulas (Beams fixed at one end, supported at other)**

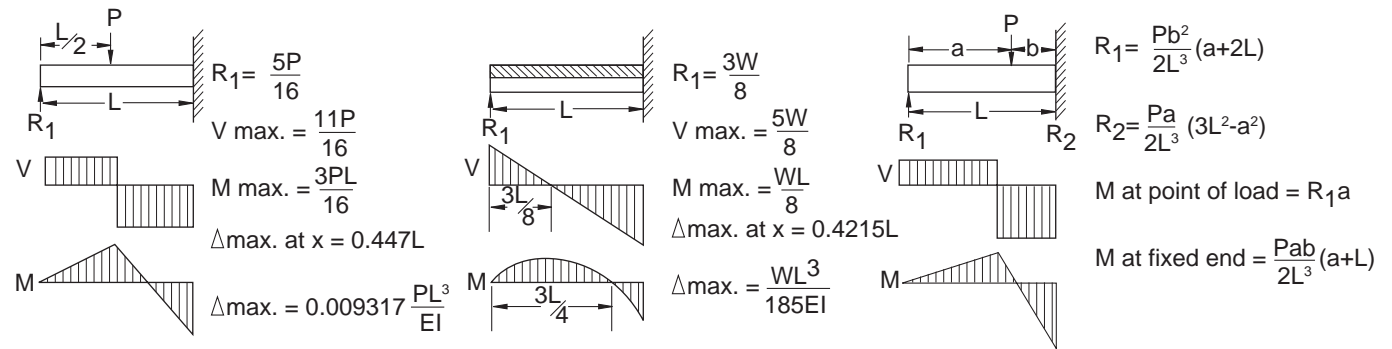



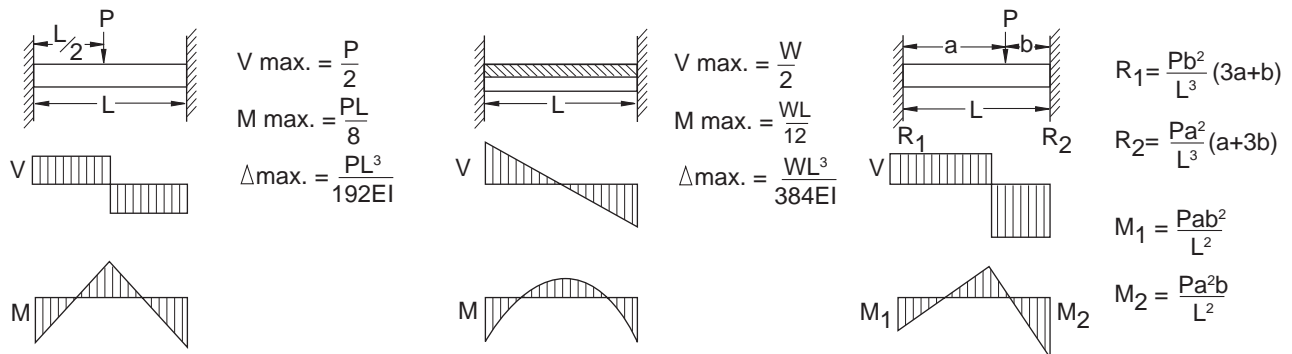





**Beam Diagrams and Formulas (Beams fixed at both ends)**

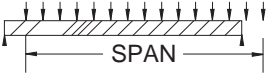

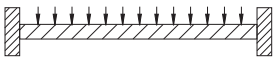
Metal Channel  
Fasteners  
Fittings  
Pipe & Conduit Clamps  
Electrical  
Concrete Inserts  
Solar Components  
Unipier®  
Jr. Channel  
Power-Angle  
Fiberglass  
Tech. Data

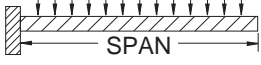
## Beam Load (Static) Conversion Factors

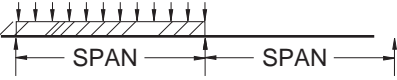
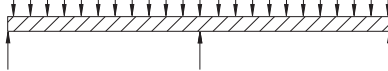
Power-Strut beam loads shown for various channels throughout this catalog are for single span, simple beams, with uniform loads. Loading or other support conditions can be calculated by multiplying the channel beam load by the appropriate factor listed below.

LOAD AND SUPPORT CONDITION	LOAD FACTOR	DEFLECTION FACTOR
<b>1. Simple Beam, Uniform Load</b> 	<b>1.00</b>	<b>1.00</b>
<b>2. Simple Beam, Concentrated Load at Center</b> 	<b>0.50</b>	<b>0.80</b>
<b>3. Simple Beam, Two Equal Concentrated Loads at 1/4 pts</b> 	<b>1.00</b>	<b>1.10</b>
<b>4. Beam Fixed at Both Ends, Uniform Load</b> 	<b>1.50</b>	<b>0.30</b>
<b>5. Beam Fixed at Both Ends, Concentrated Load at Center</b> 	<b>1.00</b>	<b>0.40</b>
<b>6. Cantilever Beam, Uniform Load</b> 	<b>0.25</b>	<b>2.40</b>
<b>7. Cantilever Beam, Concentrated Load at End</b> 	<b>0.12</b>	<b>3.20</b>
<b>8. Continuous Beam, Two Equal Spans, Uniform Load on One Span</b> 	<b>1.30</b>	<b>0.92</b>
<b>9. Continuous Beam, Two Equal Spans, Uniform Load on Both Ends</b> 	<b>1.00</b>	<b>0.42</b>
<b>10. Continuous Beam, Two Equal Spans, Concentrated Load at Center of One Span</b> 	<b>0.62</b>	<b>0.71</b>
<b>11. Continuous Beam, Two Equal Spans, Concentrated Load at Center of Each Span</b> 	<b>0.67</b>	<b>0.48</b>

### Example solutions

1.) To determine the load and deflection of a PS-200 simple beam 72" long, with a concentrated load at the center of span:  
 From the PS-200 Beam Load Chart (page 29), the maximum uniform load for a 72" span is 560# with a deflection of .50".  
 Multiply the above factors:  
 Load = 560 x .50 = 280#  
 Defl. = .50 x .80 = .40"

2.) To determine the load and deflection of a PS-200-2T3 cantilever beam 24" long with a concentrated load at end:  
 From the PS-200-2T3 Beam Load Chart (page 27), the maximum uniform load for a 24" span is 3130# with a deflection of .03".  
 Multiply the above factors:  
 Load = 3130# x .12 = 376#  
 Defl. = .03 x 3.20 = .096"

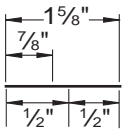

**PS 603** – PS-200 1500#, PS-210 1000#

Channel	Load (lbs)
PS 200	1,500
PS 210	1,000

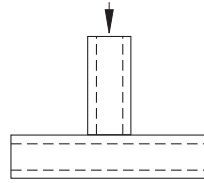

Both Ends Supported

**PS 605** – PS-200 1500#, PS-210 1000#

Channel	Load (lbs)
PS 200	1,500
PS 210	1,000

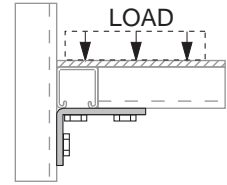

Both Ends Supported

**PS 603** – PS-200 1000#, PS-210 650#

Channel	Load (lbs)
PS 200	1,000
PS 210	650

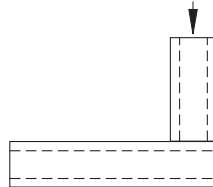

Both Ends Supported

**PS 3373** – PS-200 3000#, PS-210 2000#

Channel	Load (lbs)
PS 200	3,000
PS 210	2,000

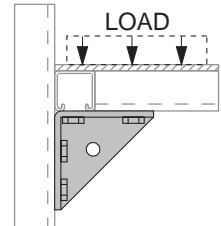

Both Ends Supported

**PS 745** – PS-200 2000#, PS-210 1500#

Channel	Load (lbs)
PS 200	2,000
PS 210	1,500

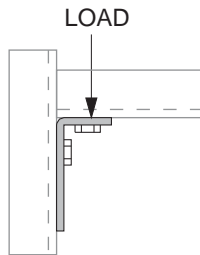

Both Ends Supported

**PS 607** – PS-200 2000#, PS-210 2000#

Channel	Load (lbs)
PS 200	2,000
PS 210	

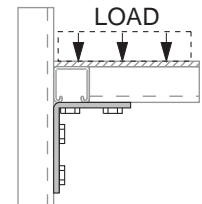

Both Ends Supported

**PS 604** – 500#

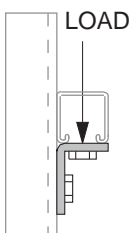

**PS 606** – 500#

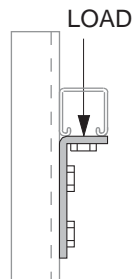

**PS-601** – PS-210 1000#, PS-210 800#

Channel	Load (lbs)
PS 200	1,000
PS 210	800

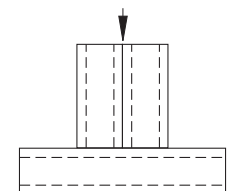

Both Ends Supported

- 1.) Safety Factor = 2½ based on ultimate strength of connection.
- 2.) Load Diagrams indicate design loads for 12 ga. (listed as PS-200) and for 14 ga. (listed as PS-210) channels.



## Tables of Pipe Spacing

This chart, developed by Julius Getlan of Seelye Stevenson Value & Knect, consulting engineers, New York City, enables one to quickly determine the centerline-to-centerline dimension between any two size pipes on a rack. Select the smaller pipe size at top and select the other at the side of the table. Where the appropriate columns intersect, the dimension is given.

These factors are included in the dimensions given:

- O.D. of flanges and fittings.
- 1" insulation over flanges and fittings.
- All fractional dimensions less than  $\frac{1}{4}$ " were increased to the next larger  $\frac{1}{4}$ ".
- Clear space between fittings as follows:
  1. 1" between piping 3" and smaller.
  2.  $1\frac{1}{2}$ " between a pipe 3" and smaller and a pipe 4" or larger.
  3. 2" between piping 4" and larger.

Normal Pipe Dia.(In.)		Normal Pipe Diameter, Inches											
		$\frac{3}{4}$ "		1"			$1\frac{1}{4}$ "			$1\frac{1}{2}$ "			
		T	S	T	F	S	T	F	S	T	F	S	
$\frac{3}{4}$	T	4 $\frac{3}{4}$	–	–	–	–	–	–	–	–	–	–	
	S	4 $\frac{1}{2}$	4 $\frac{1}{4}$										
1	T	5	4 $\frac{3}{4}$	5 $\frac{1}{4}$	–	–	–	–	–	–	–	–	
	F	6	5 $\frac{3}{4}$	6 $\frac{1}{4}$									7 $\frac{1}{4}$
	S	4 $\frac{3}{4}$	4 $\frac{1}{2}$	5									6
$1\frac{1}{4}$	T	5 $\frac{1}{4}$	5	5 $\frac{1}{2}$	6 $\frac{1}{2}$	5	5 $\frac{1}{2}$	–	–	–	–	–	
	F	6 $\frac{1}{4}$	6	6 $\frac{1}{2}$	7 $\frac{1}{2}$	6 $\frac{1}{4}$	6 $\frac{3}{4}$						7 $\frac{3}{4}$
	S	4 $\frac{3}{4}$	4 $\frac{1}{2}$	5	6	4 $\frac{1}{2}$	5 $\frac{1}{4}$						6 $\frac{1}{4}$
$1\frac{1}{2}$	T	5 $\frac{1}{4}$	5	5 $\frac{1}{2}$	6 $\frac{1}{2}$	5 $\frac{1}{4}$	5 $\frac{3}{4}$	6 $\frac{1}{4}$	5 $\frac{1}{4}$	5 $\frac{3}{4}$	–	–	
	F	6 $\frac{1}{2}$	6 $\frac{1}{4}$	6 $\frac{3}{4}$	7 $\frac{3}{4}$	6 $\frac{1}{4}$	6 $\frac{3}{4}$	8	6 $\frac{1}{2}$	7			8
	S	5	4 $\frac{3}{4}$	5 $\frac{1}{4}$	6 $\frac{1}{4}$	4 $\frac{3}{4}$	5 $\frac{1}{4}$	6	5	5 $\frac{1}{2}$			6 $\frac{1}{2}$
2	T	5 $\frac{3}{4}$	5 $\frac{1}{2}$	6	7	5 $\frac{1}{2}$	6	7 $\frac{1}{4}$	5 $\frac{3}{4}$	6 $\frac{1}{4}$	7 $\frac{1}{4}$	5 $\frac{3}{4}$	
	F	7	6 $\frac{3}{4}$	7 $\frac{1}{4}$	8 $\frac{1}{4}$	6 $\frac{3}{4}$	7 $\frac{1}{4}$	8 $\frac{1}{2}$	7	7 $\frac{1}{2}$	8 $\frac{1}{2}$	7	
	S	5 $\frac{1}{4}$	5	5 $\frac{1}{2}$	6 $\frac{1}{2}$	5	5 $\frac{1}{2}$	6 $\frac{3}{4}$	5 $\frac{1}{4}$	5 $\frac{3}{4}$	6 $\frac{3}{4}$	5 $\frac{1}{4}$	
$2\frac{1}{2}$	T	6	5 $\frac{3}{4}$	6 $\frac{1}{4}$	7 $\frac{1}{4}$	6	6 $\frac{1}{2}$	7 $\frac{1}{2}$	6	6 $\frac{1}{2}$	7 $\frac{3}{4}$	6 $\frac{1}{4}$	
	F	7 $\frac{1}{2}$	7 $\frac{1}{4}$	7 $\frac{3}{4}$	8 $\frac{3}{4}$	7 $\frac{1}{4}$	7 $\frac{3}{4}$	9	7 $\frac{1}{2}$	8	9	7 $\frac{1}{2}$	
	S	5 $\frac{1}{2}$	5 $\frac{1}{4}$	5 $\frac{3}{4}$	6 $\frac{3}{4}$	5 $\frac{1}{4}$	5 $\frac{3}{4}$	7	5 $\frac{1}{2}$	6	7	5 $\frac{1}{2}$	
3	T	6 $\frac{1}{4}$	6	6 $\frac{1}{2}$	7 $\frac{1}{2}$	6 $\frac{1}{4}$	6 $\frac{3}{4}$	7 $\frac{3}{4}$	6 $\frac{1}{4}$	6 $\frac{3}{4}$	8	6 $\frac{1}{2}$	
	F	7 $\frac{3}{4}$	7 $\frac{1}{2}$	8	9	7 $\frac{1}{2}$	8	9 $\frac{1}{4}$	7 $\frac{3}{4}$	8 $\frac{1}{4}$	9 $\frac{1}{4}$	7 $\frac{3}{4}$	
	S	5 $\frac{3}{4}$	5 $\frac{1}{2}$	6	7	5 $\frac{1}{2}$	6	7 $\frac{1}{4}$	5 $\frac{3}{4}$	6 $\frac{1}{4}$	7 $\frac{1}{4}$	5 $\frac{3}{4}$	
4	T	7 $\frac{1}{2}$	7 $\frac{1}{4}$	7 $\frac{3}{4}$	8 $\frac{3}{4}$	7 $\frac{1}{4}$	7 $\frac{3}{4}$	9	7 $\frac{1}{2}$	8	9	7 $\frac{1}{2}$	
	F	9	8 $\frac{3}{4}$	9 $\frac{1}{4}$	10 $\frac{1}{4}$	8 $\frac{3}{4}$	9 $\frac{1}{4}$	10 $\frac{1}{2}$	9	9 $\frac{1}{2}$	10 $\frac{1}{2}$	9	
	S	6 $\frac{3}{4}$	6 $\frac{1}{2}$	7	8	6 $\frac{1}{2}$	7	8 $\frac{1}{4}$	6 $\frac{3}{4}$	7 $\frac{1}{4}$	8 $\frac{1}{4}$	6 $\frac{3}{4}$	
5	T	8	7 $\frac{3}{4}$	8 $\frac{1}{4}$	9 $\frac{1}{4}$	7 $\frac{3}{4}$	8 $\frac{1}{4}$	9 $\frac{1}{2}$	8	8 $\frac{1}{2}$	9 $\frac{1}{2}$	8	
	F	9 $\frac{1}{2}$	9 $\frac{1}{4}$	9 $\frac{3}{4}$	10 $\frac{3}{4}$	9 $\frac{1}{4}$	9 $\frac{3}{4}$	11	9 $\frac{1}{2}$	10	11	9 $\frac{1}{2}$	
	S	7 $\frac{1}{4}$	7	7 $\frac{1}{2}$	8 $\frac{1}{4}$	7	7 $\frac{1}{2}$	8 $\frac{3}{4}$	7 $\frac{1}{4}$	7 $\frac{3}{4}$	8 $\frac{3}{4}$	7 $\frac{1}{4}$	
6	T	8 $\frac{3}{4}$	8 $\frac{1}{2}$	9	10	8 $\frac{1}{2}$	9	10 $\frac{1}{4}$	8 $\frac{3}{4}$	9 $\frac{1}{4}$	10 $\frac{1}{4}$	8 $\frac{3}{4}$	
	F	10	9 $\frac{3}{4}$	10 $\frac{1}{4}$	11 $\frac{1}{4}$	9 $\frac{3}{4}$	10 $\frac{1}{4}$	11 $\frac{1}{2}$	10	10 $\frac{1}{2}$	11 $\frac{1}{2}$	10	
	S	7 $\frac{3}{4}$	7 $\frac{1}{2}$	8	9	7 $\frac{1}{2}$	8	9 $\frac{1}{4}$	7 $\frac{3}{4}$	8 $\frac{1}{4}$	9 $\frac{1}{4}$	7 $\frac{3}{4}$	
8	T	8 $\frac{3}{4}$	9 $\frac{1}{2}$	10	11	9 $\frac{3}{4}$	10 $\frac{1}{2}$	11 $\frac{1}{4}$	9 $\frac{3}{4}$	10 $\frac{1}{4}$	11 $\frac{1}{2}$	10	
	F	11 $\frac{1}{4}$	11	11 $\frac{1}{2}$	12 $\frac{1}{2}$	11	11 $\frac{1}{2}$	12 $\frac{3}{4}$	11 $\frac{1}{4}$	11 $\frac{3}{4}$	12 $\frac{3}{4}$	11 $\frac{1}{4}$	
10	T	11 $\frac{1}{4}$	11	11 $\frac{1}{2}$	12 $\frac{1}{2}$	11	11 $\frac{1}{2}$	12 $\frac{3}{4}$	11 $\frac{1}{4}$	11 $\frac{3}{4}$	12 $\frac{3}{4}$	11 $\frac{1}{4}$	
	F	12 $\frac{1}{2}$	12 $\frac{1}{4}$	12 $\frac{3}{4}$	13 $\frac{3}{4}$	12 $\frac{1}{4}$	12 $\frac{3}{4}$	14	12 $\frac{1}{2}$	13	14	12 $\frac{1}{2}$	
12	T	12 $\frac{1}{4}$	12	12 $\frac{1}{2}$	13 $\frac{1}{2}$	12	12 $\frac{1}{2}$	13 $\frac{3}{4}$	12 $\frac{1}{4}$	12 $\frac{3}{4}$	13 $\frac{3}{4}$	12 $\frac{1}{4}$	
	F	14	13 $\frac{3}{4}$	14 $\frac{1}{4}$	15 $\frac{1}{4}$	13 $\frac{3}{4}$	14 $\frac{1}{4}$	15 $\frac{1}{2}$	14	14 $\frac{1}{2}$	15 $\frac{1}{2}$	14	

T – denotes threaded IPS pipe.  
 F – denotes flanged fittings on pipe.  
 S – denotes soldered or brazed tubing.

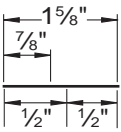

**Tables of Pipe Spacing (cont.)**



Nominal Pipe Dia. (In.)	Nominal Pipe Diameter, Inches												
	2"			2½"			3"			4"			
	T	F	S	T	F	S	T	F	S	T	F	S	
2	T	6½	–	–	–	–	–	–	–	–	–	–	
	F	7¾	9	–	–	–	–	–	–	–	–	–	
	S	6	7¼	5½	–	–	–	–	–	–	–	–	
2½	T	7	8¼	6½	7¼	–	–	–	–	–	–	–	
	F	8¼	9½	7¾	8¾	10	–	–	–	–	–	–	
	S	6¼	7½	5¾	6¾	8	6	–	–	–	–	–	
3	T	7¼	8½	6¾	7½	9	7	7¾	–	–	–	–	
	F	8½	9¾	8	9	10¼	8¼	9¼	10½	–	–	–	
	S	6½	7¾	6	7	8¼	6¼	7¼	8½	6½	–	–	
4	T	8¼	9½	7¾	8¾	10	8	9	10¼	8¼	10	–	
	F	9¾	11	9¼	10¼	11½	9½	10½	11¾	9¾	11½	13	
	S	7½	8¾	7	8	9¼	7¼	8¼	9½	7½	9¼	10¾	8½
5	T	8¾	10	8¼	9¼	10½	8½	9½	10¾	8¾	10¼	12	9¾
	F	10¼	11½	9¾	10¾	12	10	11	12¼	10¼	12	13½	11¼
	S	8	9¼	7½	8½	9¾	7¾	8¾	10	8	9¾	11¼	9
6	T	9½	10¾	9	10	11¼	9¼	10¼	11½	9½	11¼	12¾	10½
	F	10¾	12	10¼	11¼	12½	10½	11½	12¼	10¾	12½	14	11¾
	S	8½	9¾	8	9	10¼	8¼	9¼	10½	8½	10¼	11¾	9½
8	T	10¾	12	10½	11	12½	10½	11¼	12¾	10¾	12½	14	11¾
	F	12	13¾	11½	12½	13¾	11¾	12¾	14	12	13¾	15¼	13
	S	10¾	12	10½	11	12½	10½	11¼	12¾	10¾	12½	14	11¾
10	T	12	13¾	11½	12½	13¾	11¾	12¾	14	12	13¾	15¼	13
	F	13¾	14½	12¾	13¾	15	13	14	15¼	13¼	15	16½	14¼
	S	12	13¾	11½	12½	13¾	11¾	12¾	14	12	13¾	15¼	13
12	T	13	14¾	12½	13½	14¾	12¾	13¾	15	13	14¾	16¼	14
	F	14¾	16	14¼	15¼	16½	14½	15½	16¾	14¾	16½	18	15¾
	S	13	14¾	12½	13½	14¾	12¾	13¾	15	13	14¾	16¼	14

Nominal Pipe Dia. (In.)	Nominal Pipe Diameter, Inches											
	5"			6"			8"		10"		12"	
	T	F	S	T	F	S	T	F	T	F	T	F
5	T	11	–	–	–	–	–	–	–	–	–	–
	F	12½	14	–	–	–	–	–	–	–	–	–
	S	10¼	11¾	9½	–	–	–	–	–	–	–	–
6	T	11¾	13¼	11	12½	–	–	–	–	–	–	–
	F	13	14½	12¼	13¾	15	–	–	–	–	–	–
	S	10¾	12¼	10	11½	12¾	10½	–	–	–	–	–
8	T	13	14½	12¼	13¾	15	12¾	14¾	–	–	–	–
	F	14¼	15¾	13½	15	16¼	14	16¼	17 ½	–	–	–
	S	13	14½	12¼	13¾	15	12¾	14¾	–	–	–	–
10	T	14¼	15¾	13½	15	16¼	14	16¼	17½	17½	–	–
	F	15½	17	14¾	16¼	17½	15¼	17½	18¾	18¾	20	–
	S	14¼	15¾	13½	15	16¼	14	16¼	17½	17½	–	–
12	T	15¼	16¾	14½	16	17¼	15	17¼	18½	18½	19¾	19½
	F	17	18¼	16¼	17¾	19	16¾	18	19¼	19¼	21½	21¼
	S	15¼	16¾	14½	16	17¼	15	17¼	18½	18½	19¾	19½

T – denotes threaded IPS pipe.  
 F – denotes flanged fittings on pipe.  
 S – denotes soldered or brazed tubing.

Metal Channel  
Fasteners  
Fittings  
Pipe & Conduit Clamps  
Electrical  
Concrete Inserts  
Solar Components  
Unipier®  
Jr. Channel  
Power-Angle  
Fiberglass  
Tech. Data

**Minimum Size Power-Strut Channel - To Comply with NFPA 13 Table 2-6.1 5(a) 1996 Edition**

Channel Size	Sect. Mod. (in <sup>3</sup> )
 <p><b>PS-200</b> 1<sup>5</sup>/<sub>8</sub>" x 1<sup>5</sup>/<sub>8</sub>" x 12 ga.</p>	<b>.202</b>
 <p><b>PS-150</b> 1<sup>5</sup>/<sub>8</sub>" x 2<sup>7</sup>/<sub>16</sub>" x 12 ga.</p>	<b>.391</b>
 <p><b>PS-100</b> 1<sup>5</sup>/<sub>8</sub>" x 3<sup>3</sup>/<sub>4</sub>" x 12 ga.</p>	<b>.628</b>

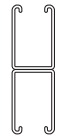
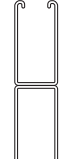
Channel Size	Sect. Mod. (in <sup>3</sup> )
 <p><b>PS-150 2T3</b> 1<sup>5</sup>/<sub>8</sub>" x 4<sup>7</sup>/<sub>8</sub>" x 12 ga.</p>	<b>1.153</b>
 <p><b>PS-100 2T3</b> 1<sup>5</sup>/<sub>8</sub>" x 6<sup>1</sup>/<sub>2</sub>" x 12 ga.</p>	<b>1.716</b>

**Section Modulus Required for Trapeze Members (in.<sup>3</sup>)**

Span of Trapeze	Pipe Size											
	1"	1 <sup>1</sup> / <sub>4</sub> "	1 <sup>1</sup> / <sub>2</sub> "	2"	2 <sup>1</sup> / <sub>2</sub> "	3"	3 <sup>1</sup> / <sub>2</sub> "	4"	5"	6"	8"	10"
1 ft. 6 in.	0.08	0.09	0.09	0.09	0.10	0.11	0.12	0.13	0.15	0.18	0.24	0.32
	0.08	0.09	0.09	0.10	0.11	0.12	0.13	0.15	0.18	0.22	0.30	0.41
2 ft. 0 in.	0.11	0.12	0.12	0.13	0.13	0.15	0.16	0.17	0.20	0.24	0.32	0.43
	0.11	0.12	0.12	0.13	0.15	0.16	0.18	0.20	0.24	0.29	0.40	0.55
2 ft. 6 in.	0.14	0.14	0.15	0.16	0.17	0.18	0.20	0.21	0.25	0.30	0.40	0.54
	0.14	0.15	0.15	0.16	0.18	0.21	0.22	0.25	0.30	0.36	0.50	0.68
3 ft. 0 in.	0.17	0.17	0.18	0.19	0.20	0.22	0.24	0.26	0.31	0.36	0.48	0.65
	0.17	0.18	0.18	0.20	0.22	0.25	0.27	0.30	0.36	0.43	0.60	0.82
4 ft. 0 in.	0.22	0.23	0.24	0.25	0.27	0.29	0.32	0.34	0.41	0.48	0.64	0.87
	0.22	0.24	0.24	0.26	0.29	0.33	0.36	0.40	0.48	0.58	0.80	1.09
5 ft. 0 in.	0.28	0.29	0.30	0.31	0.34	0.37	0.40	0.43	0.51	0.59	0.80	1.08
	0.28	0.29	0.30	0.33	0.37	0.41	0.45	0.49	0.60	0.72	1.00	1.37
6 ft. 0 in.	0.33	0.35	0.36	0.38	0.41	0.44	0.48	0.51	0.61	0.71	0.97	1.30
	0.34	0.35	0.36	0.39	0.44	0.49	0.54	0.59	0.72	0.87	1.20	1.64
7 ft. 0 in.	0.39	0.40	0.41	0.44	0.47	0.52	0.55	0.60	0.71	0.83	1.13	1.52
	0.39	0.41	0.43	0.46	0.51	0.58	0.63	0.69	0.84	1.01	1.41	1.92
8 ft. 0 in.	0.44	0.46	0.47	0.50	0.54	0.59	0.63	0.68	0.81	0.95	1.29	1.73
	0.45	0.47	0.49	0.52	0.59	0.66	0.72	0.79	0.96	1.16	1.61	2.19
9 ft. 0 in.	0.50	0.52	0.53	0.56	0.61	0.66	0.71	0.77	0.92	1.07	1.45	1.95
	0.50	0.53	0.55	0.59	0.66	0.74	0.81	0.89	1.08	1.30	1.81	2.46
10 ft. 0 in.	0.56	0.58	0.59	0.63	0.68	0.74	0.79	0.85	1.02	1.19	1.61	2.17
	0.56	0.59	0.61	0.65	0.74	0.82	0.90	0.99	1.20	1.44	2.01	2.74

PS-100

PS-150 2T3

PS-100 2T3

Exceeds Section Modulus for Channel Shown Above

Top values are for Schedule 10 pipe; bottom values are for Schedule 40 Pipe.

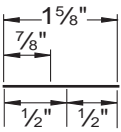

## Electrical Metallic Tubing Data

Nom. Size EMT Conduit	OD Conduit	Conduit Wt. lbs./ft	Approx. Max Wt. (lbs.ft.) Conduit and Conductor Not Lead Covered
1/2	0.706	0.29	0.54
3/4	0.922	0.45	1.16
1	1.163	0.65	1.83
1 1/4	1.510	0.96	2.96
1 1/2	1.740	1.11	3.68
2	2.197	1.41	4.45
2 1/2	2.875	2.15	6.41
3	3.500	2.60	9.30
3 1/2	4.000	3.25	12.15
4	4.500	3.90	15.40

## Application Engineering Data - Conduit Spacings

Spacings in inches between centers of conduits. The light face figures are the minimum dimensions to provide clearance between locknuts. The more liberal spacings printed in bold face type should be used whenever possible.

Size	Size												
	1/2"	3/4"	1"	1 1/4"	1 1/2"	2"	2 1/2"	3"	3 1/2"	4"	4 1/2"	5"	6"
1/2"	1 3/16	-	-	-	-	-	-	-	-	-	-	-	-
	1 3/8												
3/4"	1 5/16	1 7/16	-	-	-	-	-	-	-	-	-	-	-
	1 1/2	1 5/8											
1"	1 1/2	1 5/8	1 3/4	-	-	-	-	-	-	-	-	-	-
	1 3/4	1 7/8	2										
1 1/4"	1 3/4	1 7/8	2	2 1/4	-	-	-	-	-	-	-	-	-
	2	1 5/8	2 1/4	2 1/2									
1 1/2"	1 15/16	2 1/16	2 3/16	2 7/16	2 9/16	-	-	-	-	-	-	-	-
	2 1/8	2 1/4	2 3/8	2 5/8	2 3/4								
2"	2 3/16	2 5/16	2 1/2	2 3/4	2 7/8	3 1/8	-	-	-	-	-	-	-
	2 3/8	2 1/2	2 3/4	3	3 3/8	3 3/8							
2 1/2"	2 7/16	2 9/16	2 3/4	3	3 1/8	3 3/8	3 5/8	-	-	-	-	-	-
	2 5/8	2 3/4	3	3 1/4	3 3/8	3 5/8	4						
3"	2 13/16	2 15/16	3 1/16	3 5/16	3 7/16	3 3/4	4	4 5/16	-	-	-	-	-
	3	3 1/8	3 3/8	3 5/8	3 3/4	4	4 3/8	4 3/4					
3 1/2"	3 1/8	3 1/4	3 3/8	3 5/8	3 3/4	4 1/16	4 5/16	4 5/8	4 15/16	-	-	-	-
	3 3/8	3 1/2	3 5/8	3 3/8	4	4 3/8	4 5/8	5	5 5/8				
4"	3 7/16	3 9/16	3 11/16	3 15/16	4 1/16	4 3/8	4 5/8	4 15/16	5 1/4	5 9/16	-	-	-
	3 3/4	3 7/8	4	4 1/4	4 3/8	4 3/4	5	5 3/8	5 5/8	6			
4 1/2"	3 3/4	3 7/8	4	4 1/4	4 3/8	4 5/8	4 7/8	5 1/4	5 9/16	5 7/8	6 1/8	-	-
	4	4 1/8	4 1/4	4 1/2	4 3/4	5	5 1/4	5 5/8	6	6 1/4	6 1/2		
5"	4 1/8	4 1/4	4 3/8	4 5/8	4 3/4	5	5 1/4	5 9/16	5 7/8	6 3/16	6 1/2	6 13/16	-
	4 3/8	4 1/2	4 5/8	4 7/8	5	5 3/8	5 5/8	6	6 1/4	6 5/8	7	7 1/4	
6"	4 3/4	4 7/8	5	5 1/4	5 3/8	5 5/8	5 7/8	6 3/16	6 1/2	6 13/16	7 1/8	7 1/16	8 1/8
	5	5 1/8	5 1/4	5 1/2	5 5/8	6	6 1/4	6 5/8	7	7 1/4	7 5/8	8	8 5/8

Metal Channel  
Fasteners  
Fittings  
Pipe & Conduit Clamps  
Electrical  
Concrete Inserts  
Solar Components  
Unipier®  
Jr. Channel  
Power-Angle  
Fiberglass  
Tech. Data

## Steel Rigid Conduit Data

Nom. Size Rigid Conduit	OD Conduit	OD Coupling	Wt. Conduit W/C Pkg. lbs./ft	Approx. Max Wt.(lbs./ft.) Conduit and Conductor	
				Lead Covered	Not Lead Covered
½"	0.840	1.010	0.80	1.17	1.04
¾"	1.050	1.250	1.09	1.75	1.40
1"	1.315	1.525	1.65	2.62	2.35
1¼"	1.660	1.869	2.15	4.31	3.58
1½"	1.900	2.155	2.58	5.89	4.55
2"	2.375	2.650	3.52	8.53	7.21
2½"	2.875	3.250	5.67	11.51	10.22
3"	3.500	3.870	7.14	16.51	14.51
3½"	4.000	4.500	8.60	19.05	17.49
4"	4.500	4.875	10.00	24.75	21.48
5"	5.563	6.000	13.20	35.87	30.83
6"	6.625	7.200	17.85	50.69	43.43

Maximum weight equals weight of rigid conduit plus weight of heaviest conductor combination as specified by the 1996 edition of the "National Electrical Code Handbook."

## Intermediate Metal Conduit Data

Nom. Size Rigid Conduit	OD Conduit	OD Coupling	Wt. Conduit W/C Pkg. lbs./ft	Approx. Max Wt.(lbs./ft.) Conduit and Conductor	
				Lead Covered	Not Lead Covered
½"	0.815	1.010	0.60	0.97	0.84
¾"	1.029	1.250	0.82	1.48	1.13
1"	1.290	1.525	1.16	2.13	1.86
1¼"	1.638	1.869	1.50	3.66	2.93
1½"	1.883	2.115	1.82	5.13	3.79
2"	2.360	2.650	2.42	7.43	6.11
2½"	2.857	3.250	4.28	10.12	8.83
3"	3.476	3.870	5.26	14.63	12.63
3½"	3.971	4.500	6.12	16.57	15.01
4"	4.466	4.875	6.82	21.57	18.30

1 Cubic ft. of water weighs 62.35 lbs.

1 Gallon US weighs 8.335 lbs.

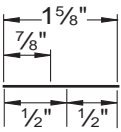

**Steel Pipe Data - Schedule 40 & 80**

Nominal Pipe Size	Sch. No.	O.D.	Wall Thick	Wt./Ft.	Wt. of Water/Ft
3/8"	40	0.675	0.091	0.567	0.083
	80		0.126	0.738	0.061
1/2"	40	0.840	0.109	0.850	0.132
	80		0.147	1.087	0.101
3/4"	40	1.050	0.133	1.130	0.230
	80		0.154	1.473	0.186
1"	40	1.315	0.133	1.678	0.374
	80		0.179	2.171	0.311
1 1/4"	40	1.660	0.140	2.272	0.647
	80		0.199	2.996	0.555
1 1/2"	40	1.900	0.145	2.717	0.882
	80		0.200	3.631	0.765
2"	40	2.375	0.154	3.652	1.452
	80		0.218	5.022	1.279
2 1/2"	40	2.875	0.203	5.790	2.072
	80		0.276	7.660	1.834
3"	40	3.500	0.216	7.570	3.200
	80		0.300	10.250	2.860
3 1/2"	40	4.000	0.226	9.110	4.280
	80		0.318	12.510	3.850
4"	40	4.500	0.237	10.790	5.510
	80		0.337	14.980	4.980
5"	40	5.563	0.258	14.620	8.660
	80		0.375	20.780	7.870
6"	40	6.625	0.280	18.970	12.510
	80		0.432	28.570	11.290
8"	40	8.625	0.322	28.550	21.600
	80		0.500	43.390	19.800
10"	40	10.750	0.365	40.480	34.100
	80		0.593	64.400	31.100
12"	40	12.750	0.406	53.600	48.500
	80		0.687	88.600	44.000
14"	40	14.000	0.437	63.000	58.500
	80		0.750	107.000	51.200
16"	40	16.000	0.500	83.000	76.500
	80		0.843	137.000	69.700
18"	40	18.000	0.563	105.000	97.200
	80		0.937	171.000	88.500
20"	40	20.000	0.593	123.000	120.400
	80		1.031	209.000	109.400
24"	40	24.000	0.687	171.000	174.200
	80		1.218	297.000	158.200
30"	20	30.000	0.500	158.000	286.000
36"	API	36.000	0.500	190.000	417.000

Metal Channel  
Fasteners  
Fittings  
Pipe & Conduit Clamps  
Electrical  
Concrete Inserts  
Solar Components  
Unipier®  
Jr. Channel  
Power-Angle  
Fiberglass  
Tech. Data

## Copper Tube Data

Type L					
Tube Size	Nom O.D. Tubing	O.D.	Wall Thick	Wt./Ft. Lbs.	Wt. of Water/Ft. Lbs.
1/4"	3/8"	0.375	0.030	0.126	0.034
3/8"	1/2"	0.500	0.035	0.198	0.062
1/2"	5/8"	0.625	0.040	0.285	0.100
5/8"	3/4"	0.750	0.042	0.362	0.151
3/4"	7/8"	0.875	0.045	0.455	0.209
1"	1 1/8"	1.125	0.050	0.655	0.357
1 1/4"	1 3/8"	1.375	0.055	0.884	0.546
1 1/2"	1 5/8"	1.625	0.060	1.140	0.767
2"	2 1/8"	2.125	0.070	1.750	1.341
2 1/2"	2 5/8"	2.625	0.080	2.480	2.064
3"	3 1/8"	3.125	0.090	3.330	2.949
3 1/2"	3 5/8"	3.625	0.100	4.290	3.989
4"	4 1/8"	4.125	0.110	5.380	5.188
5"	5 1/8"	5.125	0.125	7.610	8.081
6"	6 1/8"	6.125	0.140	10.200	11.616
8"	8 1/8"	8.125	0.200	19.290	20.289
10"	10 1/8"	10.125	0.250	30.100	31.590
12"	12 1/8"	12.125	0.280	40.400	45.426

Type K					
Tube Size	Nom O.D. Tubing	O.D.	Wall Thick	Wt./Ft. Lbs.	Wt. of Water/Ft. Lbs.
1/4"	3/8"	0.375	0.035	0.145	0.032
3/8"	1/2"	0.500	0.005	0.269	0.055
1/2"	5/8"	0.625	0.049	0.344	0.094
5/8"	3/4"	0.750	0.049	0.418	0.144
3/4"	7/8"	0.875	0.065	0.641	0.188
1"	1 1/8"	1.125	0.065	0.839	0.337
1 1/4"	1 3/8"	1.375	0.065	1.040	0.527
1 1/2"	1 5/8"	1.625	0.072	1.360	0.743
2"	2 1/8"	2.125	0.083	2.060	1.310
2 1/2"	2 5/8"	2.625	0.095	2.920	2.000
3"	3 1/8"	3.125	0.109	4.000	2.960
3 1/2"	3 5/8"	3.625	0.120	5.120	3.900
4"	4 1/8"	4.125	0.134	6.510	5.060
5"	5 1/8"	5.125	0.160	9.670	8.000
6"	6 1/8"	6.125	0.192	13.870	11.200
8"	8 1/8"	8.125	0.271	25.900	19.500
10"	10 1/8"	10.125	0.338	40.300	30.423
12"	12 1/8"	12.125	0.405	57.800	43.675

## Spacing of Hangers for Copper Tubing

Tube Size	1/2"	3/4"	1"	1 1/4"	1 1/2"	2"	2 1/2"	3"	3 1/2"	4"	5"	6"	8"	10"	12"
Span in Ft.	6	8	8	10	10	10	12	12	12	12	12	14	14	18	19

## Spacing of Hangers for Steel Pipe

Nominal Pipe Size, Inches	1/2"	3/4"	1"	1 1/4"	1 1/2"	2"	2 1/2"	3"	3 1/2"	4"	5"	6"	8"	10"	12"	14"	16"	18"	20"	24"
Maximum Span, Ft.*	5	6	7	7	9	10	11	12	13	14	16	17	19	2	23	25	27	28	30	32
Recommended Hanger Rod Sizes	3/8"	3/8"	3/8"	3/8"	3/8"	3/8"	1/2"	1/2"	1/2"	5/8"	5/8"	3/4"	7/8"	7/8"	7/8"	1"	1"	1 1/4"	1 1/2" or Trapeze	

The above spacing and capacities are based on pipe filled with water.  
 Additional valves and fittings increase the load and therefore closer hanger spacing is required.  
 \* Many codes and specifications state "pipe hangers must be spaced every 10 ft., regardless of size".  
 Follow local specifications.

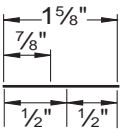

**PVC Plastic Pipe Data - Schedule 40 & 80**

Nom. Tube Size	Sch. No.	O.D.	Wall Thick	Wt./Ft. Lbs.	Wt. of Water/Ft.Lbs.
1/8"	40	0.405	0.068	0.043	0.025
	80		0.095	0.055	0.016
1/4"	40	0.540	0.088	0.074	0.045
	80		0.119	0.094	0.031
3/8"	40	0.675	0.091	0.100	0.083
	80		0.126	0.129	0.061
1/2"	40	0.840	0.109	0.150	0.132
	80		0.147	0.150	0.101
3/4"	40	1.050	0.113	0.199	0.230
	80		0.154	0.259	0.186
1"	40	1.315	0.133	0.295	0.374
	80		0.179	0.382	0.311
1 1/4"	40	1.660	0.140	0.400	0.647
	80		0.191	0.527	0.555
1 1/2"	40	1.990	0.145	0.478	0.882
	80		0.200	0.639	0.765
2"	40	2.375	0.154	0.643	1.452
	80		0.218	0.884	1.279

Nom. Tube Size	Sch. No.	O.D.	Wall Thick	Wt./Ft. Lbs.	Wt. of Water/Ft.Lbs.
2 1/2"	40	2.875	0.203	1.020	2.072
	80		0.276	1.350	1.834
3"	40	3.500	0.216	1.333	3.200
	80		0.300	1.804	2.860
3 1/2"	40	4.000	0.226	1.598	4.280
	80		0.318	2.195	3.850
4"	40	4.500	0.237	1.899	5.510
	80		0.337	2.636	4.980
5"	40	5.563	0.258	2.770	8.660
	80		0.375	4.126	7.870
6"	40	6.625	0.280	3.339	12.150
	80		0.432	5.028	11.290
8"	40	8.625	0.322	5.280	21.600
	80		0.500	8.023	19.800
10"	40	10.750	0.366	7.505	34.100
	80		0.593	11.894	31.100
12"	40	12.750	0.406	10.023	48.500
	80		0.687	16.365	44.000

**Spacing of Hangers for PMC Plastic Pipe**

Sch. 40	Support Spacings in Feet at Temperatures Shown Above									
Pipe Size	20°F	40°F	60°F	80°F	100°F	110°F	120°F	130°F	140°F	150°F
1/2" - 3/4"	5.00	4.75	4.50	4.25	4.00	3.75	3.33	3.00	2.66	2.00
1" - 1 1/4"	5.50	5.25	5.00	4.66	4.33	4.00	3.75	3.33	2.80	2.25
1 1/2" - 2"	5.80	5.50	5.25	5.00	4.66	4.33	3.80	3.50	3.00	2.50
2 1/2"	6.66	6.33	6.00	5.50	5.25	4.80	4.50	4.00	3.50	2.80
3"	6.80	6.50	6.25	5.80	5.50	5.25	4.75	4.25	3.66	3.00
4"	7.33	7.00	6.50	6.25	5.80	5.50	5.00	4.50	3.80	3.25
6"	7.80	7.50	7.00	6.80	6.33	5.80	5.33	4.80	4.25	3.50

Sch. 40	Support Spacings in Feet at Temperatures Shown Above									
Pipe Size	20°F	40°F	60°F	80°F	100°F	110°F	120°F	130°F	140°F	150°F
1/2" - 3/4"	5.75	5.50	5.25	4.80	4.50	4.33	3.80	3.50	3.00	2.50
1"	6.33	6.00	5.75	5.33	5.00	4.60	4.33	3.80	3.33	2.75
1 1/4" - 1 1/2"	6.66	6.33	6.00	5.66	5.25	4.80	4.50	4.00	3.50	3.00
2"	7.00	6.50	6.25	6.00	5.50	5.12	4.75	4.33	3.66	3.12
2 1/2"	7.80	7.50	7.00	6.66	6.33	5.80	5.33	4.75	4.25	3.33
3"	8.20	7.75	7.33	7.00	6.50	6.00	5.50	5.00	4.33	3.50
4"	8.66	8.25	7.80	7.33	6.80	6.33	5.80	5.25	4.66	3.75
6"	9.80	9.33	8.80	8.33	7.80	7.33	6.50	6.00	5.12	4.25

Metal Channel  
Fasteners  
Fittings  
Pipe & Conduit Clamps  
Electrical  
Concrete Inserts  
Solar Components  
Unipier®  
Jr. Channel  
Power-Angle  
Fiberglass  
Tech. Data



## Cast Iron Pipe Data

Nom. Tube Size	Class	O.D.	Wall Thick	Wt./ Ft.	Wt. of Water Ft. Lbs.
3"	150	3.96	0.32	12.20	3.73
4"	150	4.80	0.35	16.40	5.72
6"	150	6.90	0.38	25.70	12.80
8"	150	9.05	0.41	36.70	23.10
10"	150	11.10	0.44	48.70	35.50
12"	150	13.20	0.48	62.90	51.00
14"	150	15.30	0.51	78.80	69.30
16"	150	17.40	0.54	95.00	90.30
18"	150	19.50	0.58	114.70	114.00
20"	150	21.60	0.62	135.90	141.50
24"	150	25.80	0.73	190.40	201.00
30"	150	32.00	0.85	277.30	312.00
36"	150	38.30	0.94	368.90	449.00
42"	150	44.50	1.05	479.10	612.00
48"	150	50.80	1.14	595.20	803.00

Mechanical Joint Pipe Class 150. Approximately same weight for Bell & Spigot. Flange cast iron pipe add weight of flanges.

Nom. Pipe Size	O.D.	Wall Thick	Wt./Ft. Lbs.	Wt. of Water/Ft. Lbs.
1½"	1.84	0.12	0.64	0.89
2"	2.34	0.14	0.94	1.45
3"	3.41	0.17	1.60	3.19
4"	4.53	0.20	2.60	5.79
6"	6.66	0.24	4.70	12.78
<b>Heavy Schedule</b>				
1"	1.31	0.16	0.60	0.35
1½"	1.84	0.17	0.87	0.76
2"	2.34	0.17	1.10	1.36
3"	3.41	0.20	2.00	3.06
4"	4.53	0.26	3.40	5.44
6"	6.66	0.33	6.30	12.42

Spacing of Hangers for glass pipe support every 8-10 ft. Pad all hangers. Use only clevis or trapeze, do not tie down pipe.

## Load Carrying Capacities of Threaded Hot Rolled Steel Rod

Conforming To ASTM A575 And A576

Nominal Rod Dia.	Root Area Sq. (In.)	Maximum Safe Load, Pounds 650° (lbs.)
¾"	0.068	730
1½"	0.126	1,350
5/8"	0.202	2,160
¾"	0.302	3,230
7/8"	0.419	4,480
1"	0.552	5,900

Low Carbon Steel  
 Fy = 32,000 psi minimum  
 Ft = 52,000 psi minimum

<b>Threaded Rod Loads for Structural Applications</b> (Based on AISC, Steel Construction Manual, ASD, 9th Edition. Per AISC, Allowed Tensile Stress = 0.33 * Fu)		
Nominal Dia.	Nominal Area In <sup>2</sup>	Allowed Tension Load Lbs
¼"	0.049	840
⅜"	0.110	1,890
7/16"	0.150	2,570
½"	0.196	3,360
5/8"	0.307	5,260
¾"	0.442	7,580
7/8"	0.601	10,310
1"	0.785	13,470

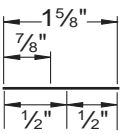

**I-Beam - "W" Shape**

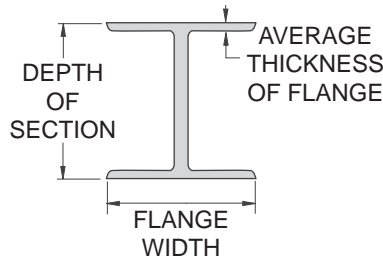

Depth of Section	Wt/ Foot	Flange Width	Avg. Flange
5"	16	5"	0.360"
	19		0.430"
6"	12	4"	0.280"
	16	4"	0.405"
	20	6"	0.365"
	25		0.455"
	13	4"	0.255"
8"	15	4"	0.315"
	18	5 1/4"	0.330"
	21		0.400"
	24	6 1/2"	0.400"
	28		0.465"
	31	8"	0.435"
	35		0.495"
	40	8 1/8"	0.560"
	48		0.685"
	58	8 1/4"	0.810"
67		0.935"	
10"	15	4"	0.270"
	17		0.330"
	19		0.395"
	22	5 3/4"	0.360"
	26		0.440"
	30		0.510"
	33	8"	0.435"
	39		0.530"
	45		0.620"
	49	10"	0.560"
	54		0.615"
	60	10 1/8"	0.680"
	68		0.770"
	77	10 1/4"	0.870"
	88		0.990"
100	10 3/8"	1.120"	
112		1.250"	
12"	16	4"	0.265"
	19		0.350"
	22		0.425"
	26	6 1/2"	0.380"
	30		0.440"
	35	6 5/8"	0.520"
	40	8"	0.515"
	45		0.575"
	50	8 1/8"	0.640"
	53	10"	0.575"
	58		0.640"
	65	12"	0.605"
	72		0.670"

Depth of Section	Wt/ Foot	Flange Width	Avg. Flange	
12" (Cont.)	79	12 1/8"	0.735"	
	87		0.810"	
	96		0.900"	
	106	12 1/4"	0.990"	
	120	12 3/8"	1.105"	
	136		1.250"	
	152	12 1/2"	1.400"	
	190	12 5/8"	1.735"	
	14"	22	5"	0.335"
		26		0.420"
30		6 3/4"	0.385"	
34			0.455"	
38			0.515"	
43		8"	0.530"	
48			0.595"	
53			0.660"	
61		10"	0.645"	
68			0.720"	
74		10 1/8"	0.785"	
82			0.855"	
90		14 1/2"	0.710"	
99		14 5/8"	0.780"	
109			0.860"	
120			0.940"	
132		14 3/4"	1.030"	
145		15 1/2"	1.090"	
159		15 5/8"	1.190"	
176			1.310"	
193		15 3/4"	1.440"	
211			1.560"	
233		15 7/8"	1.720"	
257		16"	1.890"	
283		16 1/8"	2.070"	
311	16 1/4"	2.260"		
342	16 3/8"	2.470"		
370	16 1/2"	2.660"		
398	16 5/8"	2.845"		
426	16 3/4"	3.035"		
16"	26	5 1/2"	0.345"	
	31		0.440"	
	36	7"	0.430"	
	40		0.505"	
	45		0.565"	
	50	7 1/8"	0.630"	
	57		0.715"	
	67	10 1/4"	0.665"	
	77		0.760"	
	89	10 3/8"	0.875"	

Depth of Section	Wt/ Foot	Flange Width	Avg. Flange
18"	40		0.525"
	46		0.605"
	50	7 1/2"	0.570"
	55		0.630"
	60		0.695"
	65	7 5/8"	0.750"
	71		0.810"
	76	11"	0.680"
	86	11 1/8"	0.770"
	97		0.870"
	106	11 1/4"	0.940"
119		1.060"	
21"	44	6 1/2"	0.450"
	50		0.535"
	57		0.650"
	62	8 1/4"	0.615"
	68		0.685"
	73		0.740"
	83	8 3/8"	0.835"
	93		0.930"
	111	12 3/8"	0.875"
	122		0.960"
	147	12 1/2"	1.150"
24"	55	7"	0.505"
	62		0.590"
	68	9"	0.585"
	76		0.680"
	84		0.770"
	94	9 1/8"	0.875"
	104	12 3/4"	0.750"
	117		0.850"
	131	12 7/8"	0.960"
	146		1.090"
	162	13"	1.220"
27"	84	10"	0.640"
	94		0.745"
	102		0.830"
	114	10 1/8"	0.930"
	146	14"	0.975"
	161		1.080"
	178	14 1/2"	1.190"
30"	99	10 1/2"	0.670"
	108		0.760"
	116		0.850"
	124		0.930"
	132		1.000"
	173	15"	1.065"
	191		1.185"
	211	15 1/8"	1.315"

## Channels – American Standard

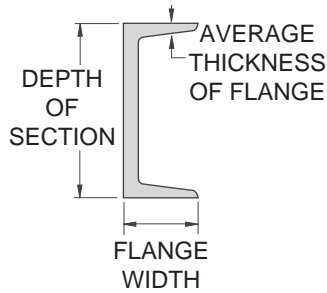

Depth of Section	Weight/Foot	Flange Width	Avg. Flange Thickness
3"	4.10	1 <sup>3</sup> / <sub>8</sub> "	0.273"
	5.00	1 <sup>1</sup> / <sub>2</sub> "	
	6.00	1 <sup>5</sup> / <sub>8</sub> "	
4"	5.40	1 <sup>5</sup> / <sub>8</sub> "	0.296"
	7.25	1 <sup>3</sup> / <sub>4</sub> "	
5"	6.70	1 <sup>3</sup> / <sub>4</sub> "	0.320"
	9.00	1 <sup>7</sup> / <sub>8</sub> "	
6"	8.20	1 <sup>7</sup> / <sub>8</sub> "	0.343"
	10.50	2"	
	13.00	2 <sup>1</sup> / <sub>8</sub> "	
7"	9.80	2 <sup>5</sup> / <sub>8</sub> "	0.366"
	12.25	2 <sup>1</sup> / <sub>4</sub> "	
	14.75		
8"	11.50	2 <sup>1</sup> / <sub>4</sub> "	0.390"
	13.75	2 <sup>3</sup> / <sub>8</sub> "	
	18.75	2 <sup>1</sup> / <sub>2</sub> "	
9"	13.40	2 <sup>3</sup> / <sub>8</sub> "	0.413"
	15.00	2 <sup>1</sup> / <sub>2</sub> "	
	20.00	2 <sup>5</sup> / <sub>8</sub> "	
10"	15.30	2 <sup>5</sup> / <sub>8</sub> "	0.436"
	20.00	2 <sup>3</sup> / <sub>4</sub> "	
	25.00	2 <sup>7</sup> / <sub>8</sub> "	
	30.00	3"	
12"	20.70	3"	0.501"
	25.00		
	30.00	3 <sup>1</sup> / <sub>8</sub> "	
15"	33.90	3 <sup>5</sup> / <sub>8</sub> "	0.650"
	40.00	3 <sup>1</sup> / <sub>2</sub> "	
	50.00	3 <sup>3</sup> / <sub>4</sub> "	
18"	42.70	4"	0.625"
	45.80		
	51.90	4 <sup>1</sup> / <sub>8</sub> "	

## I-Beams – "S" Shape

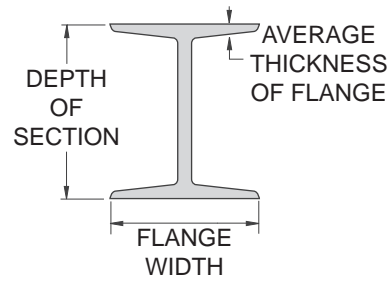

Depth of Section	Weight/Foot	Flange Width	Avg. Flange Thickness
3"	5.70	2 <sup>5</sup> / <sub>8</sub> "	0.260"
	7.50	2 <sup>1</sup> / <sub>2</sub> "	
4"	7.70	2 <sup>5</sup> / <sub>8</sub> "	0.293"
	9.50	2 <sup>3</sup> / <sub>4</sub> "	
5"	10.00	3"	0.326"
	14.75	3 <sup>1</sup> / <sub>4</sub> "	
6"	12.50	3 <sup>3</sup> / <sub>8</sub> "	0.359"
	17.25	3 <sup>5</sup> / <sub>8</sub> "	
7"	15.30	3 <sup>5</sup> / <sub>8</sub> "	0.392"
	20.00	3 <sup>7</sup> / <sub>8</sub> "	
8"	18.40	4"	0.426"
	23.00	4 <sup>1</sup> / <sub>8</sub> "	
10"	25.40	4 <sup>5</sup> / <sub>8</sub> "	0.491"
	35.00	5"	
12"	31.80	5"	0.544"
	35.00	5 <sup>1</sup> / <sub>8</sub> "	
	40.80	5 <sup>1</sup> / <sub>4</sub> "	
15"	50.00	5 <sup>1</sup> / <sub>2</sub> "	0.659"
	50.00	5 <sup>1</sup> / <sub>2</sub> "	
15"	42.90	5 <sup>1</sup> / <sub>2</sub> "	0.622"
	50.00	5 <sup>5</sup> / <sub>8</sub> "	
18"	54.70	6"	0.691"
	70.00	6 <sup>1</sup> / <sub>4</sub> "	
20"	66.00	6 <sup>1</sup> / <sub>4</sub> "	0.795"
	75.00	6 <sup>3</sup> / <sub>8</sub> "	
	86.00	7"	
	96.00	7 <sup>1</sup> / <sub>4</sub> "	
24"	80.00	7"	0.871"
	90.00	7 <sup>1</sup> / <sub>8</sub> "	
	100.00	7 <sup>1</sup> / <sub>4</sub> "	
	106.00	7 <sup>7</sup> / <sub>8</sub> "	
	121.00	8"	

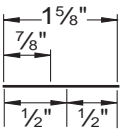

## Unit Conversions

English to Metric			Metric to English		
To Convert From	To	Multiply By	To Convert From	To	Multiply By
<b>Length</b>					
Inch [in]	Millimeter [mm]	25.400 000	Millimeter [mm]	Inch [in]	0.039 370
Foot [ft]	Meter [m]	0.304 800	Meter [m]	Foot [ft]	3.280 840
Yard [yd]	Meter [m]	0.914 400	Meter [m]	Yard [yd]	1.093 613
Mile (U.S. Statute) [mi]	Kilometer [km]	1.609 347	Kilometer [km]	Mile (U.S. Statute) [mi]	0.621 370
<b>Area</b>					
Square Inch [in <sup>2</sup> ]	Square Millimeter [mm <sup>2</sup> ]	645.16	Square Millimeter [mm <sup>2</sup> ]	Square Inch [in <sup>2</sup> ]	0.001550
Square Foot [ft <sup>2</sup> ]	Square Meter [m <sup>2</sup> ]	0.092 903	Square Meter [m <sup>2</sup> ]	Square Foot [ft <sup>2</sup> ]	10.763 915
Square Yard [yd <sup>2</sup> ]	Square Meter [m <sup>2</sup> ]	0.836 127	Square Meter [m <sup>2</sup> ]	Square Yard [yd <sup>2</sup> ]	1.195 991
Square Mile [mi <sup>2</sup> ] (U.S. Statute)	Square Kilometer [km <sup>2</sup> ]	2.589 998	Square Kilometer [km <sup>2</sup> ]	Square Mile [mi <sup>2</sup> ] (U.S. Statute)	0.386 101
Acre	Square Meter [m <sup>2</sup> ]	4,046.873	Square Meter [m <sup>2</sup> ]	Acre	0.000 247
Acre	Hectare	0.404 687	Hectare	Acre	2.471 046
<b>Volume</b>					
Cubic Inch [in <sup>3</sup> ]	Cubic Millimeter [mm <sup>3</sup> ]	16,387.06	Cubic Millimeter [mm <sup>3</sup> ]	Cubic Inch [in <sup>3</sup> ]	0.000061
Cubic Foot [ft <sup>3</sup> ]	Cubic Meter [m <sup>3</sup> ]	0.028 317	Cubic Meter [m <sup>3</sup> ]	Cubic Foot [ft <sup>3</sup> ]	35.314 662
Cubic Yard [yd <sup>3</sup> ]	Cubic Meter [m <sup>3</sup> ]	0.764 555	Cubic Meter [m <sup>3</sup> ]	Cubic Yard [yd <sup>3</sup> ]	1.307 950
Gallon (U.S. Liquid) [gal]	Litre [l]	3.785 412	Litre [l]	Gallon (U.S. Liquid) [gal]	0.264 172
Quart (U.S. Liquid) [qt]	Litre [l]	0.946 353	Litre [l]	Quart (U.S. Liquid) [qt]	1.056 688
<b>Mass</b>					
Ounce (Avoirdupois) [oz]	Gram [g]	28.349 520	Gram [g]	Ounce (Avoirdupois) [oz]	0.035 274
Pound (Avoirdupois) [lb]	Kilogram [kg]	0.453 592	Kilogram [kg]	Pound (Avoirdupois) [lb]	2.204 624
Short Ton	Kilogram [kg]	907.185	Kilogram [kg]	Short Ton	0.00110
<b>Force</b>					
Ounce-Force	Newton [N]	0.278 014	Newton [N]	Ounce-Force	3.596 941
Pound-Force [lbf]	Newton [N]	4.448 222	Newton [N]	Pound-Force [lbf]	0.224 809
<b>Bending Moment</b>					
Pound-Force-Inch [lbf-in]	Newton-Meter [N-m]	0.112 985	Newton-Meter [N-m]	Pound-Force-Inch [lbf-in]	8.850 732
Pound-Force-Foot [lbf-ft]	Newton-Meter [N-m]	1.355 818	Newton-Meter [N-m]	Pound-Force-Foot [lbf-ft]	0.737 562
<b>Pressure, Stress</b>					
Pound-Force per Square Inch [lbf/in <sup>2</sup> ]	Kilopascal [kPa]	6.894 757	Kilopascal [kPa]	Pound-Force per Square Inch [lbf/in <sup>2</sup> ]	0.145 038
Foot of Water (39.2 F)	Kilopascal [kPa]	2.988 980	Kilopascal [kPa]	Foot of Water (39.2 F)	0.334 562
Inch of Mercury (32 F)	Kilopascal [kPa]	3.386 380	Kilopascal [kPa]	Inch of Mercury (32 F)	0.295 301
<b>Energy, Work, Heat</b>					
Foot-Pound-Force [ft-lbf]	Joule [J]	1.355 818	Joule [J]	Foot-Pound-Force [ft-lbf]	0.737 562
British Thermal Unit [Btu]	Joule [J]	1,055.056	Joule [J]	British Thermal Unit [Btu]	0.000948
Calorie [cal]	Joule [J]	4.186 800	Joule [J]	Calorie [cal]	0.238 846
Kilowatt Hour [kW-h]	Joule [J]	3,600,000	Joule [J]	Kilowatt Hour [kW-h]	2.78 <sup>-7</sup>
<b>Power</b>					
Foot-Pound-Force /Second [ft-lbs/s]	Watt [W]	1.355 818	Watt [W]	Foot-Pound-Force /Second [ft-lbs/s]	0.737 562
British Thermal Unit /Hour [Btu/h]	Watt [W]	0.293 071	Watt [W]	British Thermal Unit /Hour [Btu/h]	3.412 142
Horsepower (550 Ft. Lbf/s) [hp]	Kilowatt [kW]	0.745 700	Kilowatt [kW]	Horsepower (550 Ft. Lbf/s) [hp]	1.341 022
<b>Angle</b>					
Degree	Radian [rad]	0.017 453	Radian [rad]	Degree	57.295 788
<b>Temperature</b>					
Degree Fahrenheit [F]	Degree Celsius [C]	(F° -32)/1.8	Degree Celsius [C]	Degree Fahrenheit [F]	1.8xC° +32

Metal Channel  
Fasteners  
Fittings  
Pipe & Conduit Clamps  
Electrical  
Concrete Inserts  
Solar Components  
Unipier®  
Jr. Channel  
Power-Angle  
Fiberglass  
Tech. Data

## Part Number Index

1.5 Pipe Support – Mounted, Polycarbonate Base.....	105	375PU – Fiberglass Hex Bolts.....	142
1.5 Spacer, 3-R Spacer – Spacer for Model 1.5 and Model 3-R .....	107	375PU-BC, 500PU-B – Molded Beam Clamps .....	145
2.5-CS, 16-BS thru 24-BS – Elevated Support, Polycarbonate Base ..	104	375PU-BCCLP (3/8") – Beam Clip.....	145
2.5-CS, 24-BS – Mounted Support, Polycarbonate Base.....	104	375PU-CNHD thru 750PU-CNHD, 10PU-CNMHD thru 20PU-CNMHD –	
2.5-SB-H, 5-SB-H, 8-SB-H, 8-SB-HD – Single Base Trapeze.....	109	Heavy Duty Channel Nuts .....	144
3-R, 5-R – Mounted, with Roller, Polycarbonate Base .....	105	375V thru 1000V – Vinyl Ester Square Nuts .....	143
3-RAH-7, 4-RAH-7 – Elevated Support, with Roller, Steel Base .....	107	375V – Vinyl Ester Square Head Bolts.....	143
3-RAH, 5-RAH, 6-RAH, 8-RAH –		390N – Duraclamp C-Clamps.....	146
Elevated Support, with Roller, Polycarbonate Base .....	106	20E-5000 – Fiberglass Channel Capping Strip .....	141
6-DS, 8-DS, 8-DS-DB, 10-DS – Double Base Duct Support.....	111	20N-ARM, 20NSTA – Power-Rack Stanchions .....	147
6-DSA, 8-DSA – Double Base Duct Support.....	111	20P-1000, 20V-1000, 20E-1000 – Fiberglass Standard Channel .....	133
6-H Base, 8-H Base, 16-H Base – Steel Base .....	108	20P-1100, 20V-1100 – Fiberglass Back-to-Back Channel.....	133
6-H, 8-H, 10-H, 16-H – Double Base Trapeze.....	110	20P-1200, 20V-1200, 20E-1200 –	
8-H-DB, 16-H-DB – Heavy Duty Double Base Trapeze .....	110	Fiberglass Slotted Channel (1" x 3/8" Holes).....	133
16-BS-7, 12-BS-7 – Elevated Support, Steel Base .....	105	20P-1300, 20V-1300, 20E-1300 –	
50PU-1508 (1 1/2") – Fiberglass Fitting.....	138	Fiberglass Channel With Concrete Inserts .....	133
50PU-2008 (1 5/8") – Fiberglass Fitting.....	138	20P-1500, 20V-1500 – Fiberglass Standard Channel.....	133
50PU-2045 (1 5/8") – Fiberglass Fitting.....	138	20P-1600, 20V-1600 – Fiberglass Back-to-Back Channel .....	133
50PU-2090 (1 5/8") – Fiberglass Fitting.....	138	20P-1700, 20V-1700 – Fiberglass Slotted Channel (1" x 3/8" Holes)...	133
50PU-2538 – Fiberglass Fitting.....	138	20P-1800, 20V-1800 – Fiberglass Channel With Concrete Inserts.....	133
50PU-2611 – Fiberglass Flat Fitting .....	137	20P-2000, 20V-2000, 20E-2000 – Fiberglass Standard Channel .....	133
50PU-2611-SP – Fiberglass Fitting .....	138	20P-2100, 20V-2100 – Fiberglass Back-to-Back Channel .....	133
50PU-2613 – Fiberglass Fitting.....	138	20P-2200, 20V-2200, 20E-2200 –	
50PU-2616 – Fiberglass Clevis Fitting .....	136	Fiberglass Slotted Channel (1" x 3/8" Holes).....	133
50PU-26361, 50PU-2636A2, 50PU-2636B3, 50PU-29364 –		20P-2300, 20V-2300, 20E-2300 –	
Fiberglass Fitting .....	138	Fiberglass Channel With Concrete Inserts .....	133
50PU-500SP – Fiberglass Channel Spacers .....	139	20P-2500, 20V-2500 – Fiberglass Flat Fitting .....	136
100-1500 thru 100-1514 – Hand Lay-Up Clevis Hangers .....	145	20P-2502, 20V-2502 – Fiberglass Flat Fitting.....	136
200-327 thru 200-3831 – Threaded Rod.....	146	20P-2504, 20V-2504 – Fiberglass Flat Fitting .....	136
200-3100 thru 200-3210 – Fiberglass Adjustable Pipe Clamps .....	139	20P-2506, 20V-2506 – Fiberglass Flat Fitting.....	136
200-3849 thru 200-3843 – A-Konnector Rod Couplers .....	146	20P-2508, 20V-2508 – Fiberglass Flat Fitting .....	136
200-4266 thru 200-3442 – Saddle Clips.....	144	20P-2510, 20V-2510 – Fiberglass Flat Fitting.....	136
200-4277, 200-4219, 200-4343 – Stop-Lock Assemblies.....	144	20P-2512, 20V-2512 – Fiberglass Flat Fitting.....	136
250E thru 1000E – Flat Washers .....	143	20P-2514, 20V-2514 – Fiberglass Flat Fitting.....	136
250PU thru 1000PU – Hex Nuts.....	143	20P-2516, 20V-2516 – Fiberglass Flat Fitting.....	137
250PU – Fiberglass Hex Flange Bolts.....	142	20P-2518, 20V-2518 – Fiberglass Flat Fitting.....	137
250PU-CN thru 500PU-CN , 10PU-CN thru 12PU-CN –		20P-2520, 20V-2520 – Fiberglass Flat Fitting.....	137
Standard Duty Channel Nuts.....	144	20P-2522, 20V-2522 – Fiberglass Flat Fitting.....	137
375PU thru 1000PU – Hex Flange Nuts.....	143	20P-2524, 20V-2524 – Fiberglass Flat Fitting.....	137

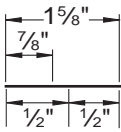

**Part Number Index**

20P-2526, 20V-2526 – Fiberglass Flat Fitting.....	137	Channel Nuts – .....	144
20P-2528, 20V-2528 – Fiberglass Flat Fitting.....	137	CVHPU – Molded Clevis Hangers.....	145
20P-2530, 20V-2530 – Fiberglass Flat Fitting.....	137	Deck Plate – Stainless Steel Deck Plate.....	107
20P-2534, 20V-2534 – Fiberglass Flat Fitting.....	137	Model 6-H, Model 8-H-DB, Model 16-H – Polycarbonate Base .....	108
20P-2540, 20V-2540 – Fiberglass Flat Fitting.....	137	PA 158 – Power-Angle, Light Duty (15/8" x 15/8" x 14 ga.).....	122
20P-2541, 20V-2541 – Fiberglass Flat Fitting.....	137	PA 1SNB – Serrated Nuts & Bolts.....	122
20P-2542, 20V-2542 – Fiberglass Fitting.....	138	PCR – Fiberglass Rigid Pipe Clamps.....	140
20P-2800, 20V-2800 – Fiberglass Grooved Fitting.....	136	PS050 thru PS 1800 – Fiberglass Two Hole Pipe Straps.....	140
20P-2802, 20V-2802 – Fiberglass Grooved Fitting.....	136	PS 51 – Right Angle Pipe or Conduit Clamp.....	72
20P-2804, 20V-2804 – Fiberglass Grooved Fitting.....	136	PS 67 – "J" Pipe or Conduit Hanger.....	70
20P-2806, 20V-2806 – Fiberglass Grooved Fitting.....	136	PS 69 – E-Z Grip Hanger.....	71
20P-2808, 20V-2808 – Fiberglass Grooved Fitting.....	136	PS 83 – Hexagon Nut.....	45
20P-2810L, 20V-2810L – Fiberglass Grooved Fitting.....	136	PS 85 – Rod or Insulator Support.....	67
20P-2810R, 20V-2810R – Fiberglass Grooved Fitting.....	136	PS 86 – "C" Clamp.....	68
20P-2812, 20V-2812 – Fiberglass Grooved Fitting.....	136	PS 93 – Universal "C" Clamp.....	68
20P-2814, 20V-2814 – Fiberglass Grooved Fitting.....	136	PS 94 – Wide Throat Top Beam "C" Clamp.....	68
20P-2816L, 20V-2816L – Fiberglass Grooved Fitting.....	137	PS 95 – "C" Clamp.....	68
20P-2816R, 20V-2816R – Fiberglass Grooved Fitting.....	137	PS 100 2T3 – Back-to-Back Channel (15/8" x 6 1/2" x 12 ga.).....	22
20P-2818, 20V-2818 – Fiberglass Grooved Fitting.....	137	PS 100 WT - Channel (15/8" x 3 1/4" x 12 ga.) with Wide Slots.....	22
20P-2820, 20V-2820 – Fiberglass Grooved Fitting.....	137	PS 100 EH – Channel (15/8" x 3 1/4" x 12 ga.) with Elongated Holes....	22
20P-2822, 20V-2822 – Fiberglass Grooved Fitting.....	137	PS 100 H – Channel (15/8" x 3 1/4" x 12 ga.) with Holes.....	22
20P-2824, 20V-2824 – Fiberglass Grooved Fitting.....	137	PS 100 K06 – Channel (15/8" x 3 1/4" x 12 ga.) with Knockouts.....	22
20P-2826, 20V-2826 – Fiberglass Grooved Fitting.....	137	PS 100 S – Channel (15/8" x 3 1/4" x 12 ga.) with Slots.....	22
20P-2828, 20V-2828 – Fiberglass Grooved Fitting.....	137	PS 100 – Channel (15/8" x 3 1/4" x 12 ga.).....	22
20P-2830, 20V-2830 – Fiberglass Grooved Fitting.....	137	PS 135 – Rod Coupling.....	46
20P-2834, 20V-2834 – Fiberglass Grooved Fitting.....	137	PS 137 – Long Tangent "U" Bolt.....	71
20P-2840, 20V-2840 – Fiberglass Grooved Fitting.....	137	PS 146 – Continuous Thread Rod.....	46
20PP-5854 (1 1/2"), 20PP-5855 (1 1/2") – Fiberglass Fitting.....	138	PS 150 2T3 – Back-to-Back Channel (15/8" x 4 7/8 x 12 ga.).....	24
20PP-5904 (3"), 20PP-5905 (2 1/4") – Fiberglass Fitting.....	138	PS 150 2T3 EH – Back-to-Back Channel (15/8" x 4 7/8" x 12 ga.) with Elongated Holes.....	24
20PU-5852 (2" Square), 20PU-5852 RD (2" Round), 20PU-5853 HD (15/8" Sq.), 20PU-5854 HD (1 1/2" Sq.) – Heavy Duty Post Base.....	148	PS 150 WT - Channel (15/8" x 2 7/16" x 12 ga.) with Wide Slots.....	24
20PU-5853 (15/8"), 20PU-5854 (1 1/2"), – Fiberglass Fitting.....	138	PS 150 EH – Channel (15/8 x 2 7/16" x 12 ga.) with Elongated Holes ...	24
20PU-5855 (15/8), 20PP-5853 (15/8"), – Fiberglass Fitting.....	138	PS 150 H – Channel (15/8 x 2 7/16" x 12 ga.) with Holes.....	24
20PU-5903 (3 1/4"), 20PU-5904 (3"), – Fiberglass Fitting.....	138	PS 150 K06 – Channel (15/8 x 2 7/16" x 12 ga.) with Knockouts.....	24
20PU-5905 (2 1/4"), 20PP-5903 (3 1/4"), – Fiberglass Fitting.....	138	PS 150 S – Channel (15/8 x 2 7/16" x 12 ga.) with Slots.....	24
20V-2BC – Fabricated Beam Clamps.....	144	PS 150 – Channel (15/8 x 2 7/16" x 12 ga.).....	24
AIC-CH – Channel Hangers.....	147	PS 200 2T2 – Welded Channel (15/8" x 3 1/4" x 12 ga.).....	28
AIC-EC – Fiberglass Channel End Cap.....	141	PS 200 2T3 – Channel (15/8" x 3 1/4" x 12 ga.).....	26

Metal Channel  
Fasteners  
Fittings  
Pipe & Conduit Clamps  
Pipe Hangers  
Electrical  
Concrete Inserts  
Solar Components  
Uniplier®  
Jr. Channel  
Power-Angle  
Fiberglass  
Tech. Data

## Part Number Index

PS 200 2T3 EH – Channel (15/8" x 31/4" x 12 ga.) with Elongated Holes.....	28	PS 349 – Continuous Concrete Insert (15/8" x 13/8").....	92
PS 200 2T4 – Welded Channel (15/8" x 31/4" x 12 ga.).....	28	PS 400 2T3 – Back-to-Back Channel (15/8" x 2" x 12 ga.).....	34
PS 200 2T5 – Welded Channel (15/8" x 31/4" x 12 ga.).....	28	PS 400 WT - Channel (15/8" x 1" x 12 ga.) with Wide Slots.....	34
PS 200 3T6 – Welded Channel (31/4" x 31/4" x 12 ga.).....	28	PS 400 EH – Channel (15/8" x 1" x 12 ga.) with Elongated Holes.....	34
PS 200 WT - Channel (15/8" x 15/8" x 12 ga.) with Wide Slots.....	26	PS 400 H – Channel (15/8" x 1" x 12 ga.) with Holes.....	34
PS 200 EH – Channel (15/8" x 15/8" x 12 ga.) with Elongated Holes.....	26	PS 400 S – Channel (15/8" x 1" x 12 ga.) with Slots.....	34
PS 200 H – Channel (15/8" x 15/8" x 12 ga.) with Holes.....	26	PS 400 – Channel (15/8" x 1" x 12 ga.).....	34
PS 200 H3 – Channel (15/8" x 15/8" x 12 ga.) with Holes.....	26	PS 449 – Continuous Concrete Insert (15/8" x 1").....	93
PS 200 K06 – Channel (15/8" x 15/8" x 12 ga.) with Knockouts.....	26	PS 500 2T3 – Back-to-Back Channel (15/8" x 15/8" x 14 ga.).....	36
PS 200 PLA – Welded Channel & Plate.....	29	PS 500 WT - Channel (15/8" x 13/16" x 14 ga.) with Wide Slots.....	36
PS 200 PLC – Welded Channel & Plate.....	29	PS 500 2T3 EH – Back-to-Back Channel (15/8" x 15/8" x 14 ga.) with Elongated Holes.....	36
PS 200 S – Channel (15/8" x 15/8" x 12 ga.) with Slots.....	26	PS 500 EH – Channel (15/8" x 13/16" x 14 ga.) with Elongated Holes... 36	
PS 200 SB – Channel (15/8" x 15/8" x 12 ga.) with Slotted Back.....	26	PS 500 H – Channel (15/8" x 13/16" x 14 ga.) with Holes.....	36
PS 200 – Channel (15/8" x 15/8" x 12 ga.).....	26	PS 500 S – Channel (15/8" x 13/16" x 14 ga.) with Slots.....	36
PS 202 – Eyelet.....	48	PS 500 – Channel (15/8" x 13/16" x 14 ga.).....	36
PS 203 – Linked Eyelet with Stud.....	48	PS 517 – Channel Nut with Stud.....	46
PS 204 – Linked Eyelets.....	48	PS 520 2T3 – Back-to-Back Channel (15/8" x 15/8" x 12 ga.).....	38
PS 205 – Eyelet with Stud.....	48	PS 520 WT - Channel (15/8" x 13/16" x 12 ga.) with Wide Slots.....	38
PS 209 – Flat Washer.....	45	PS 520 EH – Channel (15/8" x 13/16" x 12 ga.) with Elongated Holes... 38	
PS 210 2T3 – Back-to-Back Channel (15/8" x 31/4" x 14 ga.).....	30	PS 520 H – Channel (15/8" x 13/16" x 12 ga.) with Holes.....	38
PS 210 WT - Channel (15/8" x 15/8" x 14 ga.) with Wide Slots.....	30	PS 520 S – Channel (15/8" x 13/16" x 12 ga.) with Slots.....	38
PS 210 EH – Channel (15/8" x 15/8" x 14 ga.) with Elongated Holes.....	30	PS 520 – Channel (15/8" x 13/16" x 12 ga.).....	38
PS 210 H – Channel (15/8" x 15/8" x 14 ga.) with Holes.....	30	PS 520 – Channel (15/8" x 13/16" x 12 ga.).....	39
PS 210 K06 – Channel (15/8" x 15/8" x 14 ga.) with Knockouts.....	30	PS 560 2T3 – Back-to-Back Channel (15/8" x 15/8" x 16 ga.).....	40
PS 210 S – Channel (15/8" x 15/8" x 14 ga.) with Slots.....	30	PS 560 WT - Channel (15/8" x 13/16" x 16 ga.) with Wide Slots.....	40
PS 210 – Channel (15/8" x 15/8" x 14 ga.).....	30	PS 560 EH – Channel (15/8" x 13/16" x 16 ga.) with Elongated Holes... 40	
PS 211 – Lock Washer.....	46	PS 560 S – Channel (15/8" x 13/16" x 16 ga.) with Slots.....	40
PS 230 – Fender Washer.....	46	PS 560 – Channel (15/8" x 13/16" x 16 ga.).....	40
PS 231 – Slot Adapter.....	46	PS 601 – Two-Hole Splice Plate.....	50
PS 270 – Conduit Clamp.....	72	PS 602 – Three-Hole Splice Plate.....	50
PS 300 2T3 – Back-to-Back Channel (15/8" x 23/4" x 12 ga.).....	32	PS 603 – Two-Hole End Angle.....	52
PS 300 WT - Channel (15/8" x 13/8" x 12 ga.) with Wide Slots.....	32	PS 604 – Two-Hole Corner Angle.....	52
PS 300 2T3 EH – Back-to-Back Channel (15/8" x 13/8" x 12 ga.) with Elongated Holes.....	32	PS 605 – Three-Hole Corner Angle.....	52
PS 300 EH – Channel (15/8" x 13/8" x 12 ga.) with Elongated Holes.....	32	PS 606 – Three-Hole Corner Angle.....	53
PS 300 H – Channel (15/8" x 13/8" x 12 ga.) with Holes.....	32	PS 607 – Four-Hole Corner Angle.....	53
PS 300 S – Channel (15/8" x 13/8" x 12 ga.) with Slots.....	32	PS 609 – Two-Hole Offset Plate Connector.....	57
PS 300 – Channel (15/8" x 13/8" x 12 ga.).....	32	PS 611 – "Z" Support.....	57
		PS 612 – "Z" Support.....	57

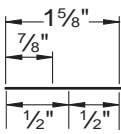

**Part Number Index**

PS 613 – U Support.....	57	PS 702 D – Fluorescent Fixture Hanger.....	86
PS 614 – Four-Hole Joint Angle Connector.....	53	PS 702 – Fluorescent Fixture Hanger.....	86
PS 615 – Five-Hole Joint Angle Connector.....	53	PS 703 D – Fluorescent Fixture Hanger.....	86
PS 617 – Three-Hole Swivel Plate.....	50	PS 703 – Fluorescent Fixture Hanger.....	86
PS 618 – Two-Hole Swivel Plate.....	50	PS 704 – Slotted Joiner.....	59
PS 619 – Square Washer.....	50	PS 707 – Aluminum Raceway Closure Strip.....	84
PS 620 – Two-Hole Connecting Plate.....	51	PS 708 – Single Channel Bracket Support.....	63
PS 621 – Four-Hole Connecting Plate.....	51	PS 709 – Three-Hole Offset Plate Connection.....	58
PS 622 – Four-Hole Corner Connector.....	54	PS 710 – U Support.....	57
PS 623 – Saddle Washer.....	58	PS 711 – "Z" Support.....	57
PS 624 – Two-Hole Closed Angle Connector.....	54	PS 712 – Cross Plate.....	51
PS 626 – Pipe Stop.....	63	PS 713 – Cross Plate Angle.....	53
PS 629 – Three-Hole Splice Clevis.....	59	PS 714 – Tee Plate.....	51
PS 631 – Two-Hole Splice Clevis.....	59	PS 715 – Tee Plate 90° Angle.....	53
PS 633 – Two-Hole Open Angle Connector.....	55	PS 716 R or L – Angle Tee Plate.....	53
PS 644 – Two-Hole Splice Clevis.....	59	PS 718 – Flat Angle Plate.....	50
PS 645 – Three-Hole Splice Clevis.....	59	PS 719 – Flat Angle Plate.....	50
PS 647 – 17/8" Offset "Z" Connector.....	56	PS 720 R or L – Angle Plate Connector.....	53
PS 651 – Reversible Channel Bracket.....	63	PS 721 – U Support.....	58
PS 653 – Type 'B' End Cap.....	92	PS 722 – Porce -A- Clamp™.....	90
PS 654 – Type 'B' End Cap.....	92	PS 732 – Shelf Bracket.....	63
PS 658 – Channel Hanger.....	86	PS 733 – Six-Hole "U" Support.....	58
PS 659 – Channel Hanger.....	86	PS 734 – Eight-Hole "U" Support.....	58
PS 660 – Four-Hole Corner Angle.....	53	PS 735 – Eight-Hole "U" Support.....	58
PS 661 T1, PS 661 T2 – Wrap-Around Channel Bracket.....	63	PS 736 – Hook Rod Assembly.....	66
PS 665 – Four-Hole Double Corner Connector.....	60	PS 744 – Flat Corner Connector.....	51
PS 666 – Six-Hole Double Corner Connector.....	60	PS 745 – Three-Hole Corner Angle.....	53
PS 667 – Eight-Hole Double Corner Connector.....	60	PS 746 – Three-Hole Corner Joint Connector.....	54
PS 668 – Six-Hole Triple Wing Connector.....	60	PS 747 – Symmetrical Four-Hole Connector.....	51
PS 669 – Twelve-Hole Triple Wing Connector.....	61	PS 748 – Four-Hole Corner Joint Connector.....	54
PS 670 – Nine-Hole Triple Wing Connector.....	61	PS 750 – Four-Hole Corner Connector.....	51
PS 671 – Strut Suspension Member.....	88	PS 752 R or L – Four-Hole Corner Connector.....	54
PS 677 – Cup Support for Standard Single Strut.....	58	PS 756 – "Z" Support.....	57
PS 678 – Three-Hole "U" Support.....	58	PS 760 – Bus Duct Connection Clevis.....	89
PS 679 – U Support.....	57	PS 763 – Slotted Adjustment Angle.....	52
PS 684 – "I" Beam Clamp.....	66	PS 764 – Slotted Adjustment Angle.....	52
PS 685 – Beam Clamp.....	65	PS 781 – Four-Hole Open Angle Connector.....	55
PS 686 – Beam Clamp.....	66	PS 791 – Electrical Box Adapter Plate.....	89
PS 692 – 15/8" Offset "Z" Connector.....	56	PS 793 – Four-Hole Closed Angle Connector.....	55

Metal Channel  
Fasteners  
Fittings  
Clamps  
Pipe & Conduit  
Electrical  
Concrete Inserts  
Solar Components  
Unipier®  
Jr. Channel  
Power-Angle  
Fiberglass  
Tech. Data



## Part Number Index

PS 803 – Fixture Wiring Nipple .....	84	PS 1200 – O.D. Tubing Clamp .....	71
PS 804 – Slotted Joiner.....	59	PS 1300 – Universal Clamp for EMT, IMC & GRC .....	70
PS 806 – Self-Aligning Two-Hole Angle .....	52	PS 1450 – One-Hole Clamp for O.D. Tubing.....	72
PS 807 – Channel Hanger.....	91	PS 1500 – Porcelain Cable Rack Insulators.....	89
PS 808 T1, PS 808 T2 – Interlocking Channel Bracket.....	63	PS 1901 – Two-Piece Pipe Roller .....	77
PS 809 – Double Channel Bracket.....	63	PS 1902 – Pipe-Roller Assembly.....	78
PS 810 – Diagonal Tube Brace .....	55	PS 1911 – Pipe Roller .....	77
PS 812 – 45° Diagonal Tube Brace .....	56	PS 2007 R or L – Six-Hole Corner Connector.....	54
PS 815 – Two-Piece, Heavy Duty Pipe Roller.....	77	PS 2008 – Two-Hole Corner Angle.....	120
PS 816 – Three Piece, Heavy Duty Pipe Roller .....	77	PS 2010 – "Z" Support .....	120
PS 821 – Eight-Hole Double Wing Connector.....	60	PS 2011 – U Support.....	120
PS 822 – Double 45° Connector .....	51	PS 2013 – Square Washer .....	119
PS 825 R or L – Single Pipe Axle Support.....	64	PS 2014 – Two-Hole Splice Plate.....	119
PS 826 – Double Pipe Axle Support.....	64	PS 2015 – Three-Hole Splice Plate.....	119
PS 838 R or L – Shelf Bracket.....	64	PS 2016 – Four-Hole Splice Plate.....	119
PS 854 – Flat Connector .....	51	PS 2017 – Two-Hole Corner Angle.....	120
PS 855 – Angular "I" Beam Clamp .....	65	PS 2018 – Three-Hole Corner Angle.....	120
PS 858 – Heavy Duty Beam Clamp .....	67	PS 2019 – Four-Hole Corner Angle.....	120
PS 865 – Wide Throat Heavy Duty Beam Clamp.....	67	PS 2023 R or L – Four-Hole Shelf Bracket.....	120
PS 871 – Safety Anchor Strap.....	67	PS 2024 – Four-Hole Corner Angle.....	120
PS 888 – Four-Hole Splice Plate.....	50	PS 2025 – Three-Hole Corner Angle.....	120
PS 889 – Five-Hole Splice Plate .....	50	PS 2026 – "Z" Support .....	120
PS 913 – Ten-Hole Double Wing Connector .....	60	PS 2029 – End Cap.....	118
PS 916 – "I" Beam Clamp.....	66	PS 2033 – Flat Angle Plate.....	119
PS 921 – One-Hole Angle .....	52	PS 2034 – Tee Plate.....	119
PS 922 R or L – Two-Hole Corner Connector .....	59	PS 2037 – Three-Hole Corner Angle.....	120
PS 923 – Five-Hole Double Wing Connector .....	60	PS 2041 – Tubing Clamps.....	120
PS 925 – Three-Hole Joint Connector.....	51	PS 2054 – Corner Connector .....	55
PS 926 – Strut Brace.....	54	PS 2064 – Double-Column Post Base .....	61
PS 927 – Five-Hole Corner Connector.....	54	PS 2094 – 4" Receptacle Box With Knock-outs .....	87
PS 928 – "Z" Support .....	57	PS 2112 – Cross Connector .....	51
PS 929 – U Support.....	58	PS 2113 – Slotted Corner Connector .....	54
PS 943 – Eight-Hole Gusseted Double Corner Connector.....	60	PS 2117 R or L – Wrap-Around Corner Connector .....	59
PS 945 – Ten-Hole Gusseted Double Wing Connector.....	60	PS 2119 – U Support.....	57
PS 978 – U Support.....	58	PS 2128 R or L – Four-Hole Corner Connector.....	60
PS 993 – Inside Clevis Hanger.....	59	PS 2129 R or L – Single Corner Gusseted Connector .....	60
PS 1000 – EMT Conduit Clamp .....	70	PS 2144 – Corner Angle.....	52
PS 1004 – Slotted Joiner.....	59	PS 2190 – Flat Corner Connector .....	51
PS 1154 – Splice Connection.....	92	PS 2404 thru PS 2408 – Wall Ladder Bracket.....	64

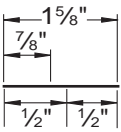

**Part Number Index**

PS 2421 – 45° Degree Stair Tread Support.....	65	PS 2801 – “T” Inside Strut Joiner .....	88
PS 2422 – 37 1/2° Degree Stair Tread Support .....	64	PS 2802 – “Elbow” Inside Strut Joiner.....	88
PS 2504 – Guided Square Washer .....	50	PS 2803 – “Cross” Inside Strut Joiner .....	88
PS 2514 – Eight-Hole Gusseted Double Corner Connector.....	60	PS 3017 – Junior Channel Nuts .....	118
PS 2520 – Slotted 90° Angle .....	52	PS 3029 – Double-Column Post Base .....	62
PS 2521 – Two-Wheel Trolley .....	62	PS 3040 – Post Base .....	61
PS 2522 – Four-Wheel Trolley .....	62	PS 3041 – Double-Column Post Base .....	61
PS 2523 – Offset Adjustable “Z” Connector .....	56	PS 3049 – Two-Hole Slotted 90° Angle .....	53
PS 2524 – Two-Bearing Light Duty Trolley.....	62	PS 3060 – Offset Connector.....	56
PS 2525 – Four-Bearing Light Duty Trolley.....	62	PS 3064 – Double-Column Post Base .....	62
PS 2528 1 – Trolley Beam Heavy Support and Track Joiner .....	62	PS 3126 – One-Piece Pipe Strap.....	72
PS 2528 – Trolley Beam Standard Support.....	62	PS 3138 – Parallel Run Pipe Clamp.....	72
PS 2532 – Shelf Attachment “Z”.....	56	PS 3164 – Double Channel Bracket Support .....	64
PS 2545 – Slotted 90° Angle .....	52	PS 3201 – Swivel Nut.....	67
PS 2601 – “Z” Support .....	57	PS 3281 – Double Conveyor Adjusting Nut.....	46
PS 2621 – Conduit Swing Fitting.....	87	PS 3282 – Cable Tray Strut Bracket.....	64
PS 2622 – Beam Clamp .....	66	PS 3301 – Mercury Vapor Fixture Hanger.....	85
PS 2623 – Swivel Adaptor.....	67	PS 3326 R or L – Six-Hole Gusseted Corner Connector.....	54
PS 2624 – Wood Beam Hanger .....	66	PS 3373 – Universal Corner Connector .....	53
PS 2625 – Wiring Stud Nut.....	84	PS 3500 – Seismic Rod Stiffener .....	48
PS 2626 – Beam Clamp .....	67	PS 3700 – Concrete Deck Insert .....	94
PS 2627 – Spacer Clevis.....	89	PS 3792 – Power-Wrap™ .....	75
PS 2631 – Swing Gate Fixture Hanger .....	85	PS 4017 – Junior Channel Nuts .....	118
PS 2632 – Swing Gate Channel Hanger .....	85	PS 6024 – Hex Head Cap Screw .....	45
PS 2636 – Fixture Stud Nut.....	86	PS 6064 – Square Head Cone Point Set Screw .....	45
PS 2637 – Fixture Nut.....	86	PS 6072 – Round Head Machine Screw .....	45
PS 2639 – Outlet Box.....	87	PS 6075 – Slotted Hex Head Machine Screw .....	45
PS 2640 – Wire Retainer.....	84	PS 6108 – Square Nut.....	45
PS 2648 – U Support.....	57	PS 6112 – Oversize Square Nut.....	45
PS 2651 – Beam Clamp.....	65	PS 6151 – Plastic Closure Strip .....	93
PS 2653 – Purlin Clamp .....	66	PS 6152 – Decorative End Cap.....	42
PS 2654 & PS 2654A – Column Attachment.....	68	PS 6153 – Strut Safety End Cap.....	42
PS 2656 – U Bolt Beam Clamp With Hook.....	65	PS 9050 – Green Touch-up Spray Paint .....	42
PS 2657 – Double U Beam Clamp .....	65	PS 9400 – Adjustable Brace.....	55
PS 2660 – Junction Box .....	87	PS 9401 – Double Adjustable Brace .....	55
PS 2661 – Junction Box Cover.....	87	PS 9402 – Two-Hole Hinge Connector.....	55
PS 2662 A – Hub Assembly.....	87	PS 9403 – Three-Hole Hinge Connector.....	56
PS 2700 – Inside Strut Joiner.....	88	PS 9404 – Four-Hole Hinge Connector.....	56
PS 2800 – Inside Strut Joiner.....	88		

Metal Channel  
Fasteners  
Fittings  
Pipe & Conduit Clamps  
Electrical  
Concrete Inserts  
Solar Components  
Unipier®  
Jr. Channel  
Power-Angle  
Fiberglass  
Tech. Data

## Part Number Index

PS 004M thru PS 038M – Cush-a-Clamp® Assembly Omega Series.....	75	PS TP – Aickin-A-Grip (SST Style Channel Only) .....	141
PS 004T thru PS 106N – Cush-a-Clamp® Assembly Pipe & Tube Series .....	74	PS TP-025 thru PS TP-100 – Cush-A-Grip®.....	73
PS 1100, PS 1116, PS 1117 – Standard Pipe Clamp (GRC, IMC and SCH 40/SCH 80 steel pipe).....	70	PS UB 1/2 – PS UB 10 – Cush-a-Clamp® Assembly U-Bolt Series .....	76
PS 135X – Light Duty Beam Clamp .....	67	RGBC – Beam Clamps.....	145
PS 2511, PS 2581 – End Cap With Knock-Out .....	84	RSS4 – Rooftop Sleeper Support.....	100-101
PS 2560, PS 2561 – Conduit Connector Fitting .....	84	SLR100 – Solar Mid-Clamp.....	97
PS 2631D – Swing Gate Fixture Hanger.....	85	SLR150 – *Solar End Clamp.....	97
PS 2632D – Swing Gate Channel Hanger .....	85	Support Pad – Polycarbonate Deck Plate .....	107
PS 3013, PS 3013 SQ – Post Base .....	61	UB-050 thru UB-600 – Nonmetallic U-bolts.....	142
PS 3025, PS 3025 FL – Post Base .....	61	UP-MPDS – Rooftop Support, Single Pier .....	102
PS 3033, PS 3033 SQ – Post Base .....	61	UP-SPSS – Rooftop Support, Dual Pier.....	102
PS 52E – Parallel Pipe and Conduit Clamp .....	75	WEEB - WMC – Electrical Equipment Bonding Washer.....	97
PS 600J – Channel (13/16" x 13/16" x 19 ga.).....	118	WR375 thru WR750 – All-Thread Washers.....	143
PS 616, PS 646 – Four-Hole Splice Clevis .....	59		
PS 649, PS 693, PS 694, PS 805, PS 942, PS 2582 – Electrical Joiner .....	88		
PS 655, PS 656, PS 901, PS 902, PS 930, PS 2580, PS 2585 – Raceway End Caps .....	84		
PS 656, PS 901 – Type 'A' End Cap .....	93		
PS 687A, PS 687B & PS 687C – Slotted "U" Support .....	58		
PS 689A, PS 689B – Double-Slotted Corner Connector.....	54		
PS 700J – Channel (13/16" x 13/32" x 19 ga.).....	119		
PS 707, PS 707 P – Raceway Closure Strip .....	84		
PS 907, PS 998 – "I" Beam Clamp.....	66		
PS CT & PS CT1 – Cush-A-Therm™.....	73		
PS KW – Kwik Washer™.....	48		
PS LS – Clamping Nut with Long Spring.....	47		
PS ML – Missing Link Multi-Purpose Strut Fastener .....	47		
PS MU-1/4 thru PS MU-4 – Mustang Universal One-Piece Pipe, Conduit (GRC, EMT & IMC) and Tubing Clamps .....	76		
PS NS S – Shallow Clamping Nut without Spring .....	47		
PS NS – Clamping Nut without Spring.....	47		
PS PP – Power-Pier .....	78		
PS RS – Clamping Nut with Long Spring .....	47		
PS SS – Clamping Nut with Short Spring.....	47		
PS TG – Top Grip™ Nut.....	47		

### Registered Trademarks of Power-Strut®:

“Power Angle”,

“Cush-A-Clamp”, “Cush-A-Grip”, &  
“Cush-A-Therm” are Registered  
Trademarks of ZSi.

*We reserve the right to make specification changes without notice.*

*While every effort has been made to assure the accuracy of information contained in this catalog at the time of publication, we cannot accept responsibility for inaccuracies resulting from undetected errors or omissions.*



**Technical Data**



Technical data entry area with horizontal lines for text input.



Allied Tube & Conduit ▲ AFC Cable Systems ▲ Heritage Plastics ▲ Unistrut  
Unistrut Construction ▲ Cope ▲ US Tray ▲ Calbrite ▲ Calbond ▲ Kaf-Tech  
Columbia-MBF ▲ Eastern Wire + Conduit ▲ ACS/Uni-Fab ▲ Cii  
Power-Strut ▲ Calconduit ▲ Razor Ribbon ▲ Calpipe Security  
Vergokan ▲ Flexicon ▲ Marco

## **Atkore**

16100 South Lathrop Avenue  
Harvey, IL 60426

**TOLL FREE / 800-882-5543**  
**FAX / 708-339-7814**

[atkore.com/unistrut](http://atkore.com/unistrut)

Want to join a company that helps you build  
the mindset, skill set and tool set for success?  
Visit us at [atkore.com/careers](http://atkore.com/careers)